

## INSTALLATION INFORMATION

### ⚠ WARNING ⚠

**Read these instructions carefully before attempting to install, operate or service this switch.**

**Failure to observe safety information and comply with instructions could result in personal injury, death and/or property damage.**

**To avoid electrical shock or damage to equipment, disconnect power before installing or servicing.**

**To avoid potential fire and/or explosion, do not use in potentially flammable or explosive atmosphere.**

**Retain these instructions for future reference. You must review your application and national and local codes to ensure that your installation will be functional and safe.**

### General Information

You are installing one of the finest switches of its type on the market. Design of this switch is based on the same principles of sensitivity, accuracy and dependability that have made Antunes Controls Air Flow Switches so successful. These switches are fully approved. They are UL listed and recognized for the U.S. and Canada, and approved by Factory Mutual (FM).

The switch is adjustable within its range, as shown on the range scale located on top of the unit.

The Model JD-2 is sturdy, compact and cost effective. All components are well made. The switch is neat in appearance, in its durable plastic electrical housing. In every way you will be pleased with the ease of installation and the reliability of your Antunes Controls JD-2 Switch.

Please read these instructions carefully to ensure correct installation. This equipment must be installed by a licensed electrician who is experienced with combustion safeguard control systems and understands the functions of interlocking switches such as air and gas pressure switches. Prior to being put into operation with combustion safeguard systems, all switches should be tested for proper range setting and wiring. Check piping connections and switch housing for leaks with a soap bubble test. All exhaust fans and blowers should be inspected and checked for proper rotation prior to start up. If you have any problems or questions, phone, fax or write to Antunes Controls at the numbers listed on the back page of this instruction sheet.

### ELECTRICAL

#### Ratings - All Models

10A, 1/8 HP, 125 VAC

5A, 1/4 HP, 250 VAC

Pilot Duty – 125 VA, 125-250 VAC

Field wiring by others must be rated at 90°C for industrial use.

Figure 1

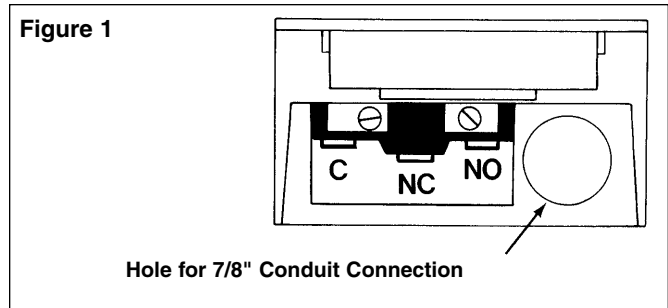

### MOUNTING

The Model JD-2 is always mounted with the stem up

An optional mounting bracket can be fastened to the bottom section of the switch housing with 5/16-18 x 1/2" bolt (supplied with bracket) as shown in Figure 2.

### AIR CONNECTIONS

#### Tubing

Recommended as minimum: 1/4" copper or aluminum tubing or 1/8" pipe. All tubing and pipe must be clean and free from oil, dirt, and chips. If piping run is over five feet long, use larger size tubing or pipe, and reduce size at switch connection.

#### Air Supply

The switch is equipped with two 1/8" NPT connection ports. Connect air supply as shown in Figure 3.

When used for vacuum or pressure applications, Model JD-2 must always be vented as shown. No venting is required for differential application.

Figure 2

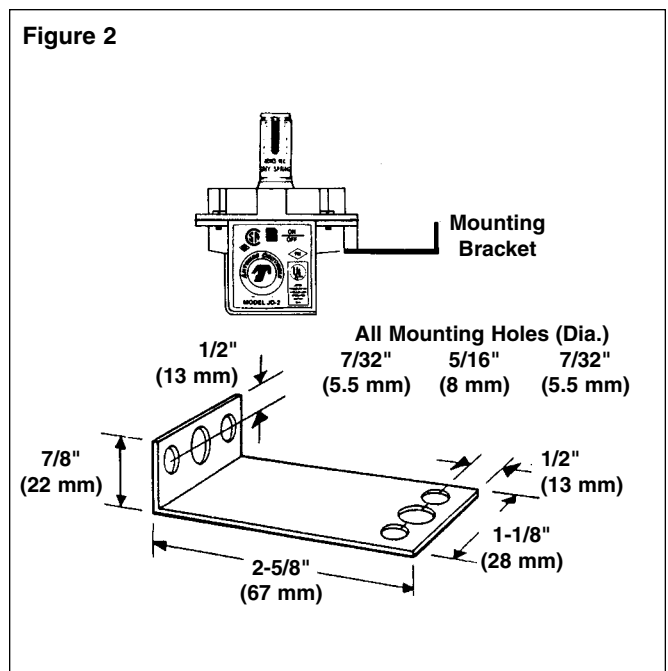
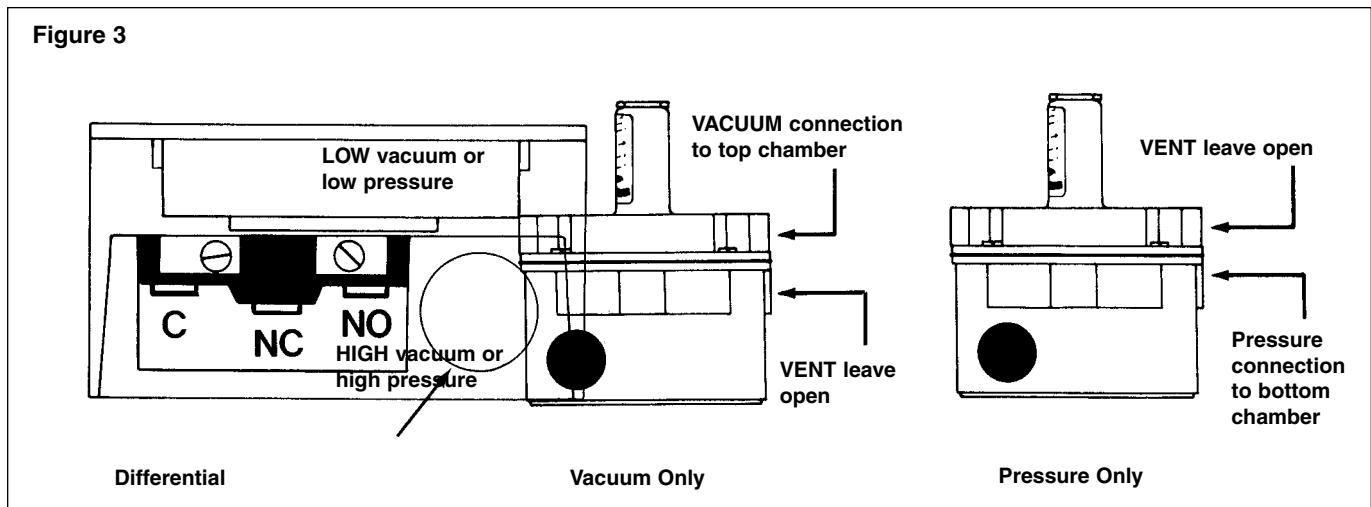

Figure 3



## Terminal Connections and Physical Dimensions

| Indicator Position | Terminal                         |
|--------------------|----------------------------------|
| OFF                | C and NO open<br>C and NC closed |
| ON                 | C and NO closed<br>C and NC open |

Figure 4

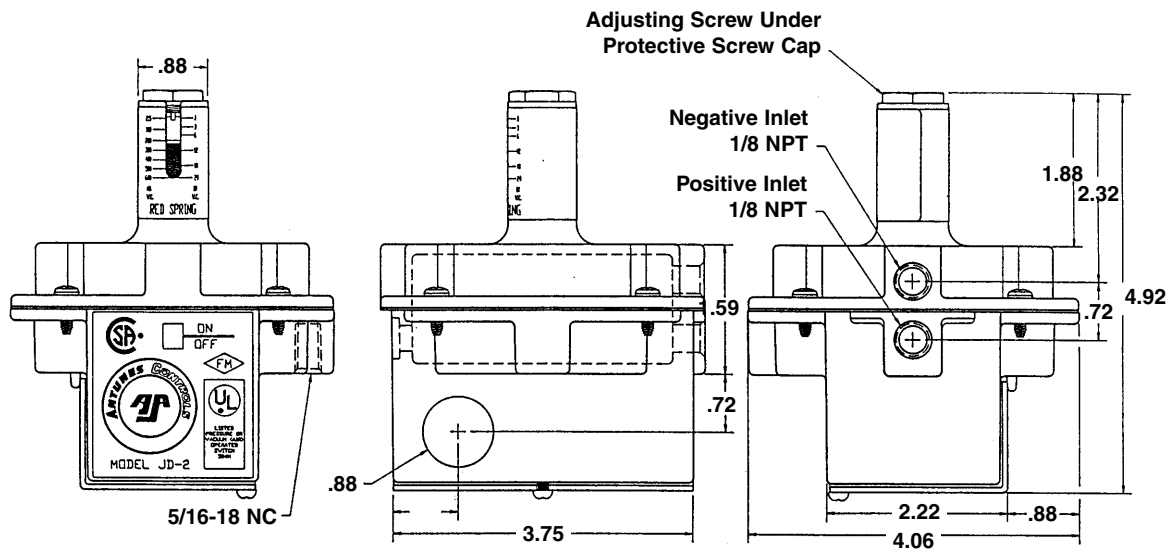

### RANGE ADJUSTMENT

#### Ranges

|               |   |
|---------------|---|
| BLUE Spring   | Adjustable from .07" W.C. to 1.7" W.C.<br>(2 mm W.C. to 43 mm W.C.) |
| GREY Spring   | Adjustable from 0.1" W.C. to 10" W.C.<br>(3 mm W.C. to 102 mm W.C.) |
| PURPLE Spring | Adjustable from 0.1" W.C. to 10" W.C.<br>(3 mm W.C. to 250 mm W.C.) |
| RED Spring    | Adjustable from 0.1" W.C. to 24" W.C.<br>(3 mm W.C. to 600 mm W.C.) |
| ORANGE Spring | Adjustable from 5" W.C. to 35" W.C.<br>(125 mm W.C. to 875 mm W.C.) |

Maximum Operating Pressure: 24" Water Column

Maximum Pressure Surge: 3 PSIG

Maximum Ambient Operating Temperature  
+140° F (+60° C)

Minimum Ambient Operating Temperature  
-20° F (-93° C)

All settings are made with the switch in horizontal position, using vacuum unless otherwise specified. Factory setting, unless otherwise specified, is with grey spring to .1" W.C.

To readjust, remove the hexagon cap screw at top of indicator stem (Figure 6). Using a screwdriver, turn the adjusting screw DOWN (clockwise) to increase pressure or UP (counterclockwise) to decrease pressure. The top of the adjustment screw is the indicator.

Slight variations in spring tension characteristics make the range setting and marking nominal. If more accurate setting is required, a "U" tube or inclined manometer should be used.

Figure 5

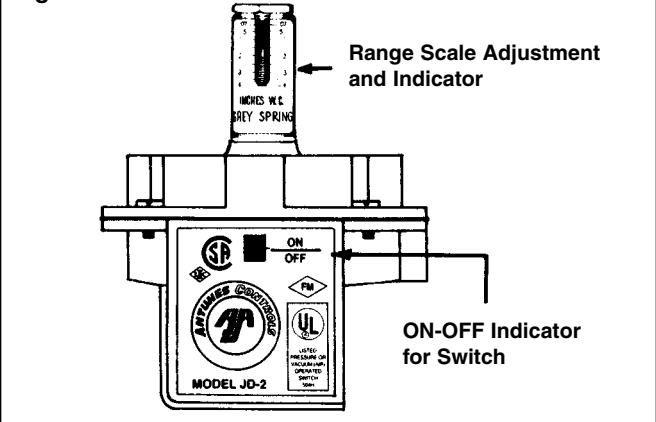
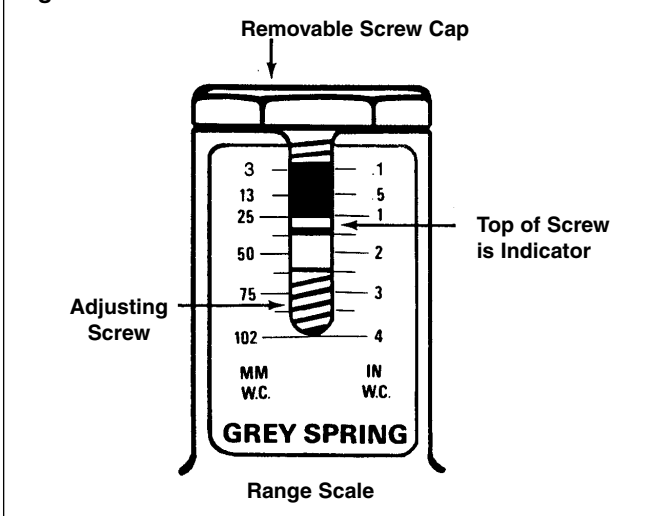

Figure 6



If adjusting screw is removed, apply a non-hardening pipe compound to the threads before re-installing. Snap-On Tool Co.'s "Never Seez" compound or equivalent is recommended. Check for leaks with a soap bubble test using maximum 1 PSI positive pressure. If screw cap is removed to adjust setting, be sure to re-install the cap to prevent tampering.

**Limitation of Liability.** If it is understood and agreed that seller's liability whether in contract, in tort, under any warranty, in negligence or otherwise, shall not exceed the return of the amount of the purchase price paid by purchaser and under no circumstances shall seller be liable for special, indirect or consequential damages. The price stated for the equipment is a consideration in limiting seller's liability. No action, regardless of form, arising out of the transactions may be brought by purchaser more than one year after the cause of action has accrued.