

Ratio Regulator/ Zero Governor

FRG/6 Series

DUNGS[®]
Combustion Controls



CSA Certified

- ANSI Z21.18 • CSA 6.3
- CSA Requirement #5.01
- Zero Governor and Gas/Air Regulator
- File # 157406

US and Canadian Models

- FRG 705/6
- FRG 707/6
- FRG 710/6
- FRG 712/6
- FRG 715/6
- FRG 720/6
- FRG 725/6
- FRG 730/6
- 1/2 in. NPT - 3 in. NPT

Commonwealth of Massachusetts Approved Product

- Approval code G3-0106-191
- Commercial / Industrial Gas Regulator

Codes and Standards:

This product is intended for installations covered by but not limited to NFPA 86, ANSI Z83.4, ANSI Z83.18, ANSI Z21.13, UL 795, CSD-1, or CSA B149.3.

DUNGS is an ISO 9001 manufacturing facility.

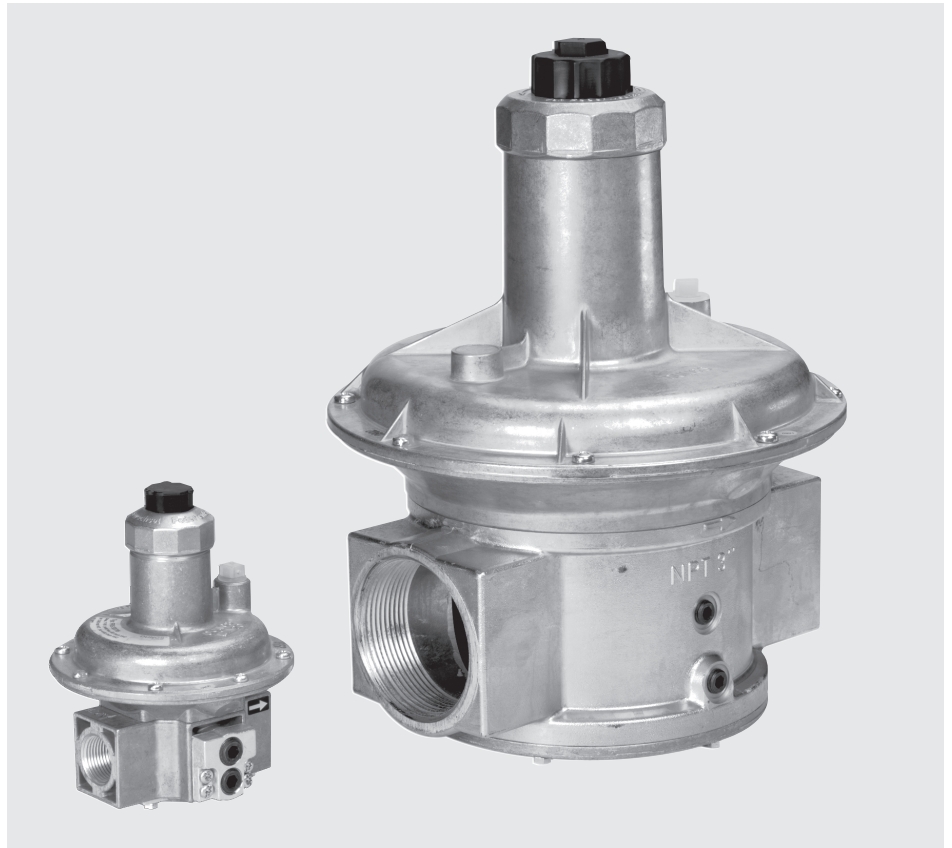

Description

The FRG ratio regulator/zero governor has an adjustable setpoint spring and nonadjustable counterspring.

- Optional Low fire bypass for 1/2 in. NPT to 2 in. NPT models. Ideal for very flow flow or for high turndown applications.
- Low hysteresis, and precise and accurate regulation of output pressure.
- Connection for air impulse line.
- Inlet and outlet 1/4 in. NPT test ports on each side.
- Factory installed vent limiter. Review applicable codes for vent line requirements.

Application (General)

The FRG is recommended for industrial and commercial heating applications. It is suitable for natural gas, propane, butane, air and inert gases. Suitable for up to 0.1% by volume, dry H₂S.

Application (Ratio Regulator)

Holds a constant gas/air ratio during turndown by varying gas flow to the burner in proportion to combustion air flow. Adjustable ratio for excess gas or air operation.

Application (Zero Governor)

Controls fuel by reducing incoming gas pressure to zero or adjustable to slightly above or below atmospheric pressure.

FRG/6 Spring-loaded ratio regulator/zero governor with adjustable setpoint spring and defined counterspring. Internal sensing of output pressure; air impulse line connection is standard.

Specifications

Pipe thread (NPT)	1/2" 3/4" 1" 1 1/4" 1 1/2" 2" 2 1/2" 3"
Max. operating pressure	7 PSI (500 mbar) Factory Rating; 5 PSI (350mbar) CSA Certified
Max. body pressure	15 PSI (1000 mbar)
Optimal inlet pressure range	Ratio regulator = 3 to 82 in. W.C. (7 to 200 mbar) Zero Governor = 3 to 20 in. W.C. (7 to 50 mbar)
Output pressure range	Ratio regulator output = 0 to 60 in. W.C. (0 mbar to 150 mbar) Zero Governor output= -2 to 2 in. W.C. (-5 mbar to 5 mbar)
Materials in contact with gas	Housing: Aluminium Seals and diaphragms: NBR
Ambient temperature	+5°F to +160 °F for up to 7 PSI for regulating behavior (+/- 10% of setpoint). -40 °F to +160 °F: Diaphragms are suitable for the low temperature, but there may be out of range regulating behavior. CSA Certified for -40 °F to +160 °F for up to 5 PSI.
Installation position	Regulator dome vertically upright or horizontally.
Test ports / Pilot gas connections	1/4 in. NPT on both sides of the inlet section and 1/4 in. NPT on both sides of the outlet section. Taps/connections only on one side when low fire bypass is used.
Low fire Bypass (Optional)	Field mountable low fire bypass: 1/2 in. NPT to 2 in. NPT on either side of housing
Vent line connection / air impulse line connection / vent limiter	<ul style="list-style-type: none"> The vent line connection/air impulse line connection is G 1/4" for FRG's up to 1" NPT, and it is G 1/2" for FRG's 1 1/4 to 3" NPT. A G thread to NPT thread field mountable adapter is available. For gas/air ratio applications at pressure ratio of approximately 1:1, use the existing connection as pressure connection for air impulse line / blower pressure, and at low fire, the air impulse line pressure shall be between 0.2 to 1.0 in WC. The FRG/6 also has a factory installed vent limiter, which limits the escape of gas to less than 0.5 CFH in case atmospheric diaphragm ruptures.
Hysteresis	+/- 10%

**Pressure taps
Pulse and blower connection**

- 1 Breathing plug/vent line connection for zero governor applications or connection for an air impulse line for ratio regulator applications.
 - 2 Pressure connection in inlet section, both sides 1/4 in. NPT.
 - 3 Pressure connection in outlet section, both sides 1/4 in. NPT.
- Low fire bypass option can be mounted on either side of valves (1/2" - 2").

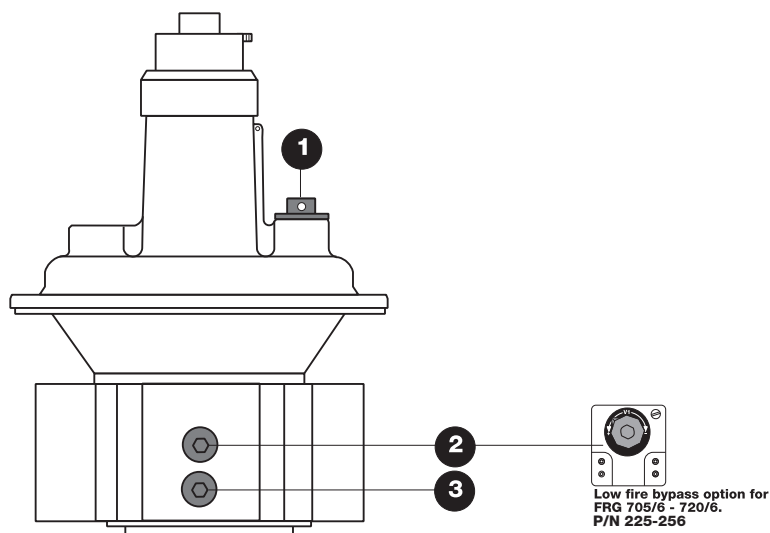

Replacement spring

Size	Order No.
FRG 705/6 NPT 1/2	229-817
FRG 707/6 NPT 3/4	229-833
FRG 710/6 NPT 1	229-842
FRG 712/6 NPT 1 1/4	229-851
FRG 715/6 NPT 1 1/2	229-851
FRG 720/6 NPT 2	229-874
FRG 725/6 NPT 2 1/2	229-883
FRG 730/6 NPT 3	229-883

Dimensions inch (mm)

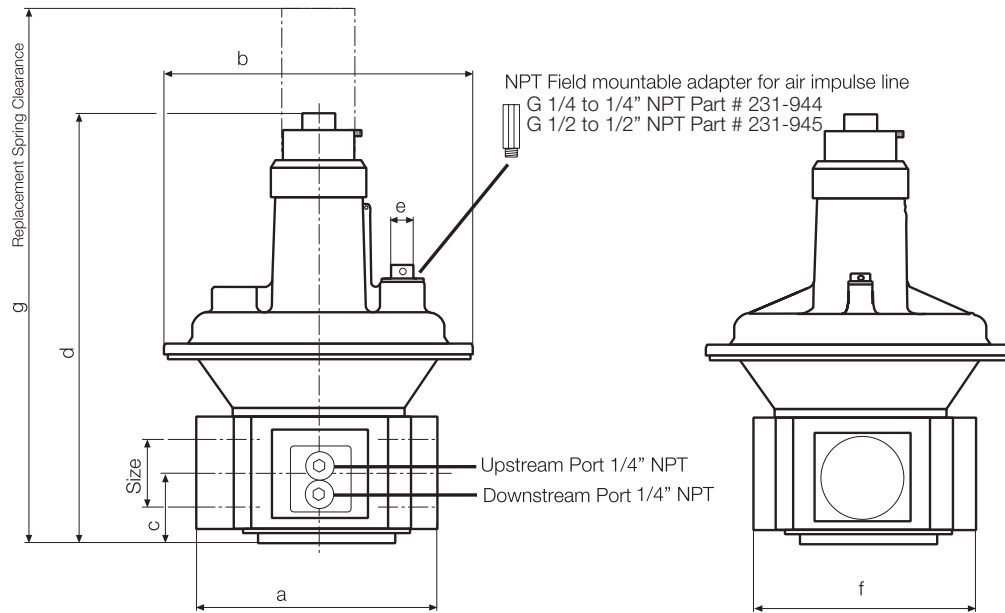

Type	Order No.	p _{max.} [PSI]	Pipe size	Dimensions [inch]						Weight [lbs]	
				a	b	c	d	e	f		g
FRG 705/6	226-458	7	NPT 1/2	2.95	4.52	0.94	5.62	G 1/4	3.47	8.86	1.32
				75	115	24	143				
FRG 707/6	226-459	7	NPT 3/4	3.94	5.12	1.1	6.5	G 1/4	3.47	9.65	2.20
				100	130	28	165				
FRG 710/6	226-460	7	NPT 1	4.33	5.71	1.3	7.48	G 1/4	4.14	12.2	2.65
				110	145	33	190				
FRG 712/6	226-461	7	NPT 1 1/4	5.9	7.68	1.57	9.84	G 1/2	5.16	14.37	5.95
				150	195	40	250				
FRG 715/6	226-462	7	NPT 1 1/2	5.9	7.68	1.57	9.84	G 1/2	5.16	14.37	5.51
				150	195	40	250				
FRG 720/6	226-463	7	NPT 2	6.69	9.84	1.85	12.2	G 1/2	5.71	17.72	7.71
				170	250	47	310				
FRG 725/6	226-464	7	NPT 2 1/2	9.06	11.22	3.74	15.95	G 1/2	6.54	23.23	16.53
				230	285	95	405				
FRG 730/6	226-465	7	NPT 3	10.43	11.22	3.74	15.95	G 1/2	7.92	23.23	22.04
				265	285	95	405				

Low fire bypass 225-256

Functional description

The FRG/6 functions according to the principle between the force of:

- the adjustable setpoint spring
- the counterspring force
- the differential pressure at the working diaphragm based on zero atmosphere.
- the air impulse line pressure and
- the force due to weight of the moving parts

The counterspring acts against the setpoint spring and the weight due to force of the moving parts. Depending on the adjustment of the setpoint spring and the installation position, the force of the counterspring is compensated.

When used as a ratio regulator, adjusting the setpoint spring or biasing for excess air/excess gas should be performed at low fire. Outlet gas pressure from the FRG is directly proportional to the air impulse line pressure. I.e. increasing the air impulse line pressure increases the outlet gas pressure.

In zero governor applications biasing (ad-

justment of the setpoint spring) leads to negative or positive regulator output pressures. Excessive adjustment of the setpoint spring leads to positive regulator output pressures.

NOTE: Materials in contact with gas, air impulse and connection lines must be of durable, crack proof material that is resistant to thermal, chemical and mechanical loads.

⚠ Do not apply combustible gas, combustible gas air mixtures to the air impulse line. Only dry air shall be used.

FRG sectional drawing

Pressure regulator shown in closed position

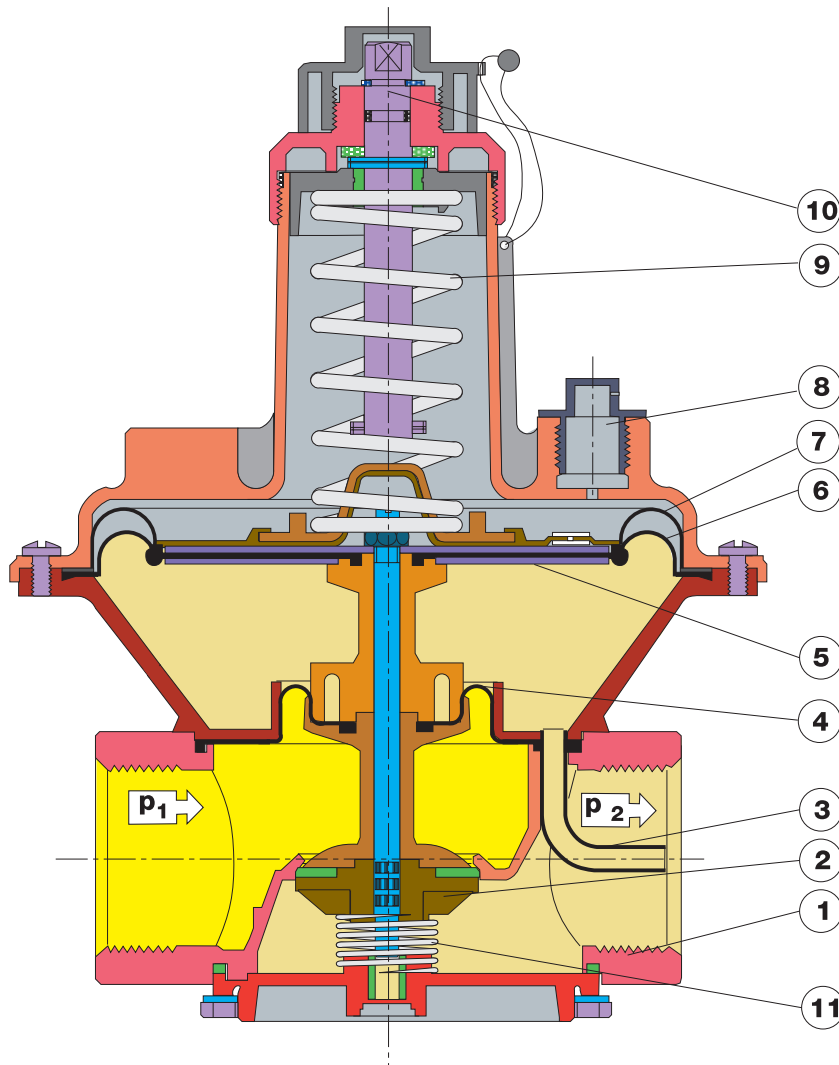

- | | | | | | |
|---|-------------------------|---|---------------------------------|----|-------------------|
| 1 | Housing | 5 | Diaphragm disk | 9 | Setpoint spring |
| 2 | Regulating disk | 6 | Working diaphragm | 10 | Adjustment device |
| 3 | Internal impulse sensor | 7 | Safety diaphragm | 11 | Counterspring |
| 4 | Compensation diaphragm | 8 | Breathing plug/air impulse line | | |

Application of zero governor (standard design)

The FRG regulates gas flow proportional to the vacuum signal, which can come from other equipment using negative pressure as the signal.

The zero governor is adjustable with the setpoint spring.

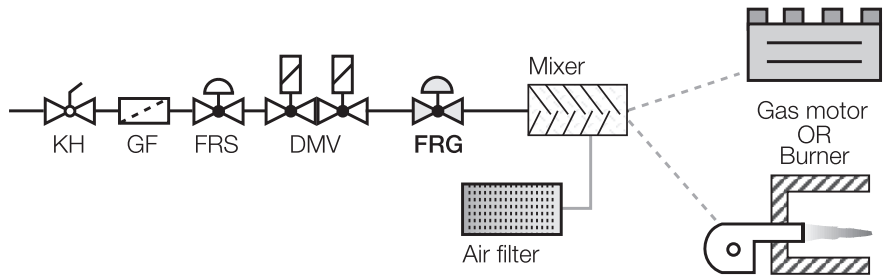

$$V_{min.} = V_{max.} \times 0.1$$

For V_{max} see flow diagram on page 8

Zero governor outlet pressure

Outlet pressure
p2 [” W.C.]
see page 4

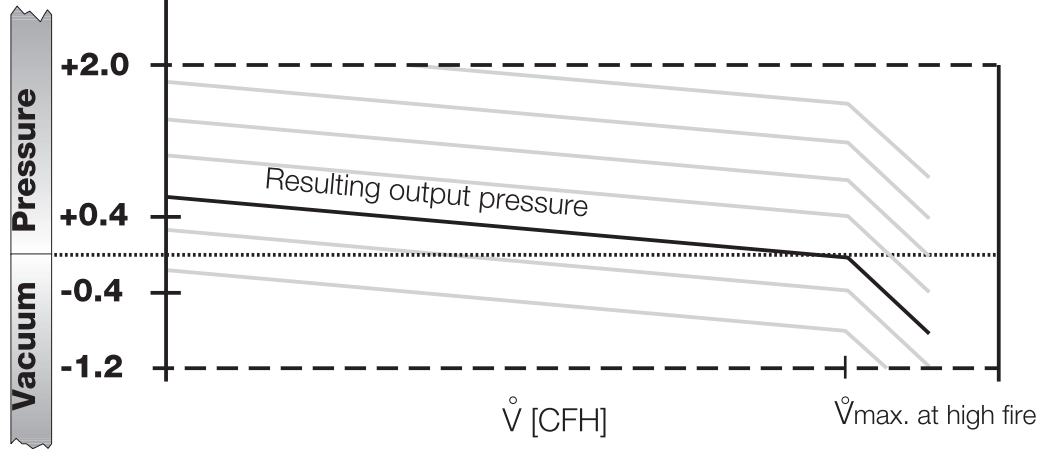

The above illustration shows adjustability (fuel biasing) of the FRG when used as a zero governor. Refer to page 8 for sizing FRG at maximum flow rate.

Application of ratio regulator (standard design)

Used as a ratio regulator for gas-air ratio applications with fixed pressure ratio $V = 1:1$ on gas equipment based on air impulse line pressure.

Internal adjustable setpoint spring for bias control; bias adjustments to be made at low fire. Lower flow rates possible with low air impulse line pressure and optional low fire bypass restrictor (225-256). Available for FRG up to 2" NPT

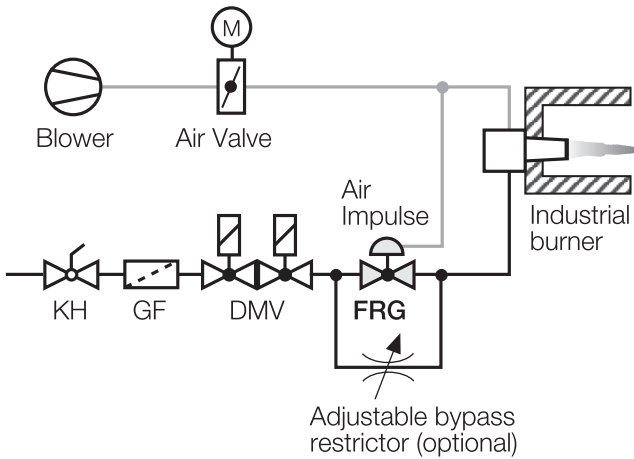

$$\dot{V}_{\min.} = \dot{V}_{\max.} \times 0.05$$

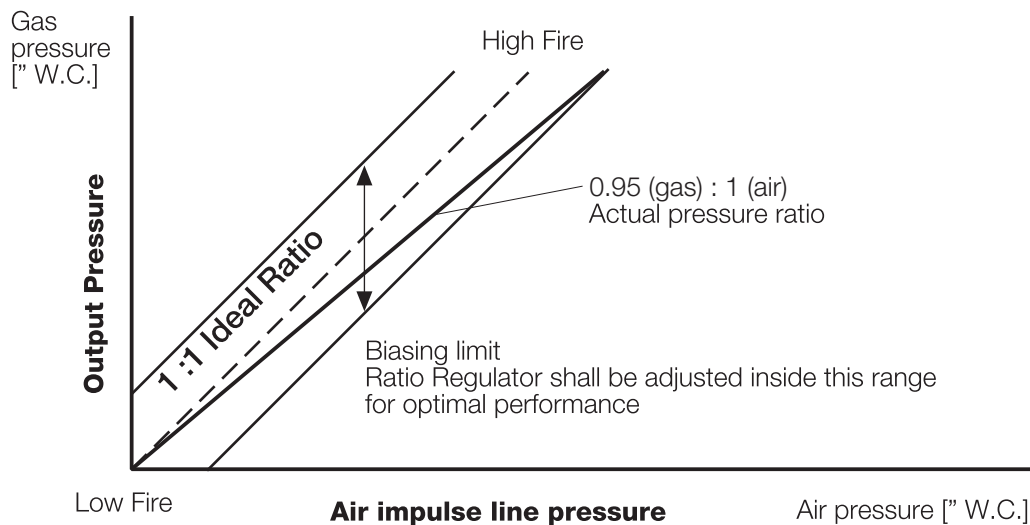

The above illustration shows that the air impulse line pressure equals the gas outlet pressure at low fire. However the air impulse line slightly exceeds the gas outlet pressure at high fire rate.

**Flow diagram
Low fire bypass**

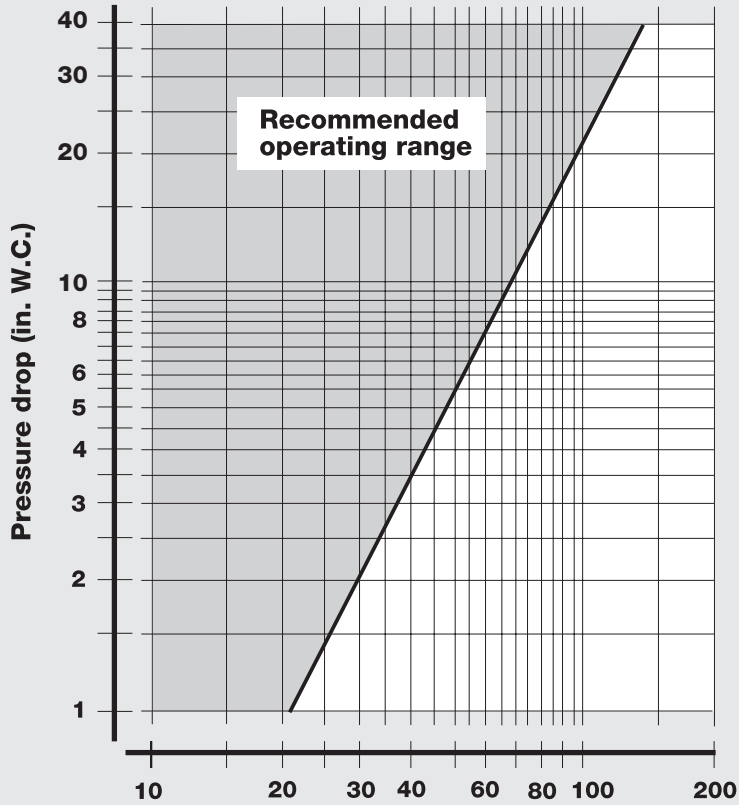

Flow (CFH) of natural gas; s.p. 0.65 at 60°F

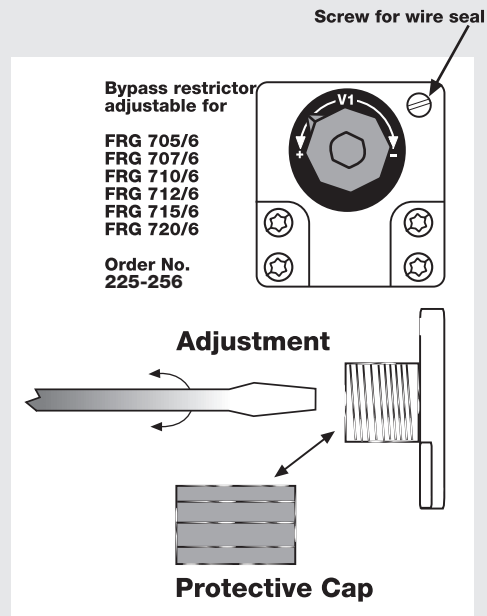

To determine the pressure drop when using a gas other than natural gas, use the flow formula below and f value located in the chart below to determine the "corrected" flow rate in CFH through the valve for the other gas used. For example, when using propane, divide the volume (CFH) of propane required for the application by the calculated value f (f = 0.66 for propane). Use this "corrected" flow rate and the flow curve on page 8 to determine pressure drop for propane.

$$\dot{V}_{\text{gas used}} = \dot{V}_{\text{Natural Gas}} \times f$$

Use this formula to calculate the f factor for other gases not listed on the table.

$$f = \sqrt{\frac{\text{Spec. gravity of Natural Gas}}{\text{Spec. gravity of gas used}}}$$

Type of gas used	Density [kg/m³]	sg	f
Natural gas	0.81	0.65	1.00
Butane	2.39	1.95	0.58
Propane	1.86	1.50	0.66
Air	1.24	1.00	0.80

**Ratio Regulator
Zero Governor**

FRG/6



**Flow Curve (mechanically opened)
Shows maximum possible flow through FRG/6**

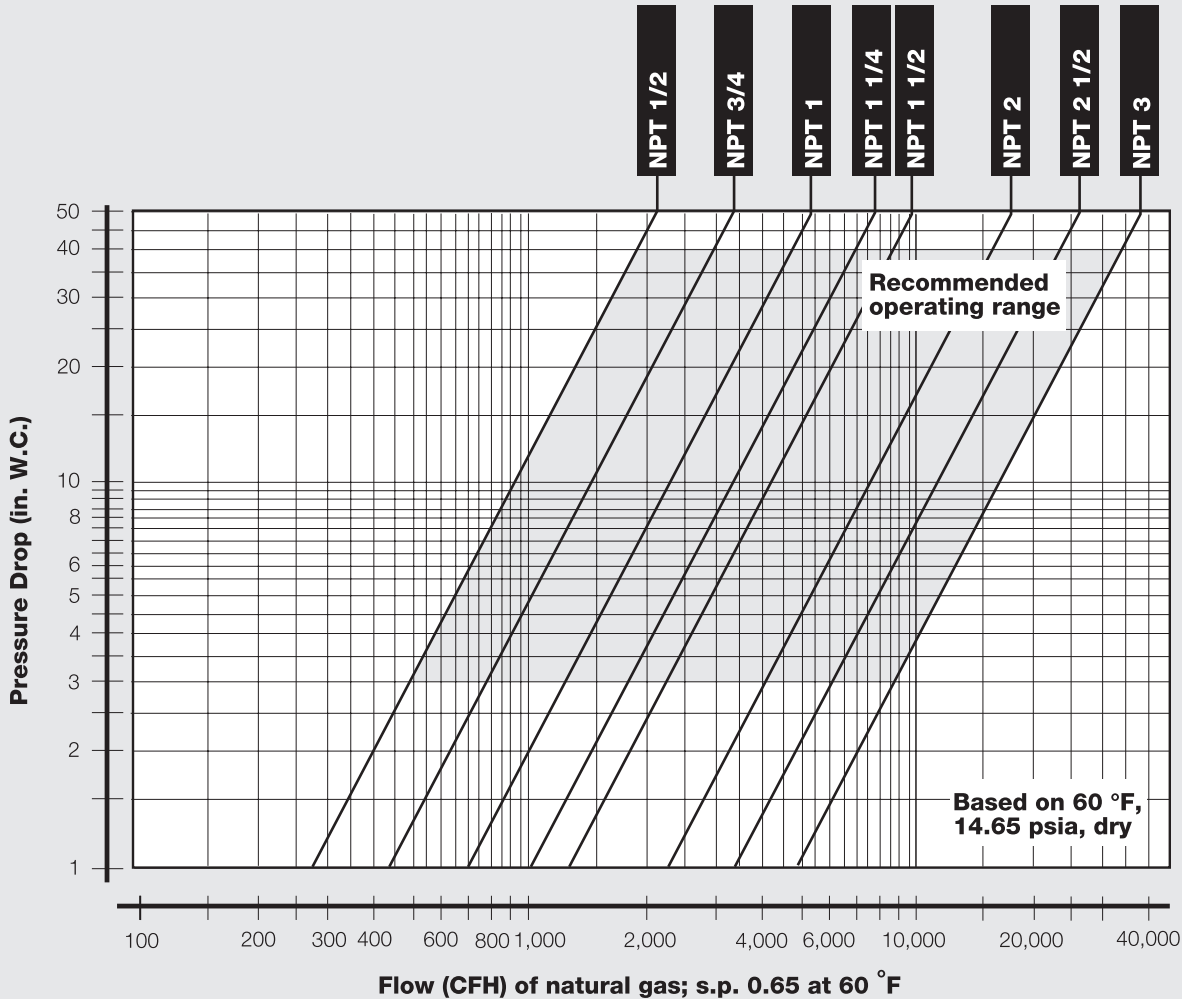

 A minimum of 3 in. W.C. Δp is required when sizing at maximum flow capacity for optimal control on high turndown applications (40:1). A 2 in. W.C. Δp can be applied for sizing if a lower turndown (in the range of 10:1) is required. Sizing the FRG/6 using a 1 in. W.C. Δp or less is not recommended.

We reserve the right to make any changes in the interest of technical progress.

Karl Dungs Inc.
524 Apollo Drive, Suite 10
Lino Lakes, MN 55014, U.S.A.
Phone 651 792-8912
Fax 651 792-8919
e-mail info@karldungsusa.com
Internet http://www.dungs.com/usa/

Karl Dungs GmbH & Co. KG
P.O. Box 12 29
D-73602 Schorndorf, Germany
Phone +49 (0)7181-804-0
Fax +49 (0)7181-804-166
e-mail info@dungs.com
Internet http://www.dungs.com