

MODEL A Gas Pressure Switch



Model HGP-A
High-Low Gas Switch
with Reset Lever



Recycle Type

The Model A is a high-low gas pressure switch that monitors pressure and cuts off the electrical control circuit when pressure drops below or rises above the desired setpoint. The high and low gas pressure settings are adjustable. All models are available in reset or recycle type.

Features

- Mount horizontally without the need for accurate leveling.
- Double switch may be ordered with any combination of high or low pressure ranges.
- Select range to meet your requirements.
- Setpoint indication.
- Rugged die-cast aluminum housing.
- Max. surge pressure: 10 PSI.
- Max. ambient temperature: 140°F (60°C).
- Min. ambient temperature: -40°F (-40°C).

Antunes Controls

Since 1962, Antunes Controls has designed and manufactured exceptional quality products for applications that require precision mechanisms. From our earliest pressure switches, which are still manufactured today with only slight modifications, to our more advanced electronic controls and timers, Antunes Controls uses only the highest quality components and the highest standards to ensure each one of our products is durable and dependable. That is why our switches and controls can be found in buildings throughout the world.



MODEL A Gas Pressure Switch

Dimensions: Single Gas Pressure Switch

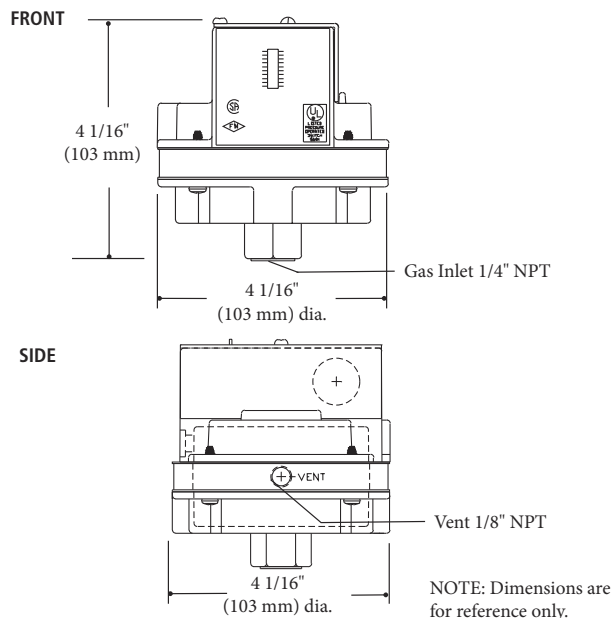

Mounting Brackets

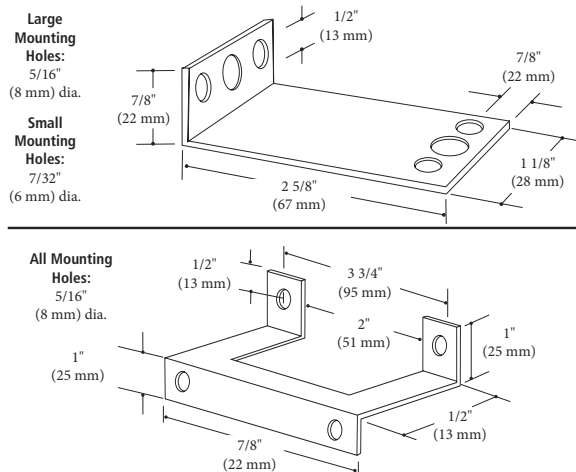

Specifications

Electrical Ratings: 10A, 1/8HP @ 125 VAC.; 5A, 1/4 HP @ 250 VAC.; Pilot Duty, 125 VA @ 125-250 VAC.

Shipping Weight: HGP-A, LGP-A, RHGP-A, RLGP-A: 2 lbs. (.9 kg)
HLGP-A, RHLGP-A: 4 lbs (1.8 kg)

Dimensions: High Low Gas Pressure Switch

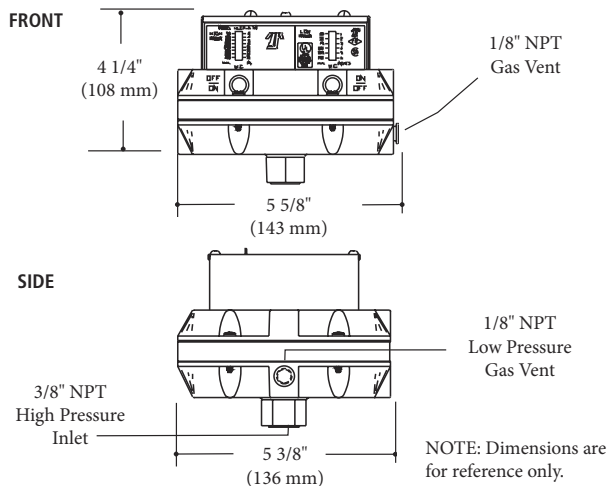

Ranges Available (All Models)

High Gas Pressure		Low Gas Pressure	
2-16" W.C.	50-400 mm	1-6" W.C.	25-150 mm
5-28" W.C.	125-700 mm	1-35" W.C.	25-875 mm
10-50" W.C.	250-1250 mm	2-14" W.C.	50-350 mm
		2-20" W.C.	50-500 mm
		6-24" W.C.	150-600 mm
		10-50" W.C.	250-1250 mm

Options

Panel Mount: Specify "Mounting Bracket" on order

Dust Proof: Specify "Dust Proof" on order (recycle type only).

Limitation of Liability. If it is understood and agreed that seller's liability whether in contract, in tort, under any warranty, in negligence or otherwise, shall not exceed the return of the amount of the purchase price paid by purchaser and under no circumstances shall seller be liable for special, indirect or consequential damages. The price stated for the equipment is a consideration in limiting seller's liability. No action, regardless of form, arising out of the transactions may be brought by purchaser more than one year after the cause of action has accrued.