



## Series 43000 Capsu-Photohelic® Pressure Switch/Gage

### Specifications - Installation and Operating Instructions

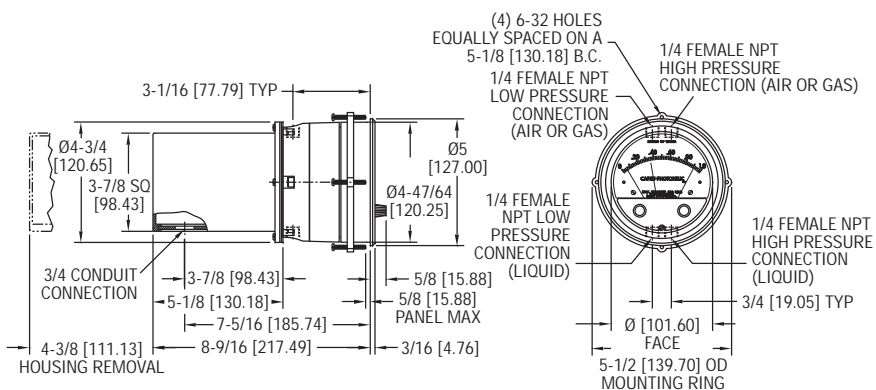
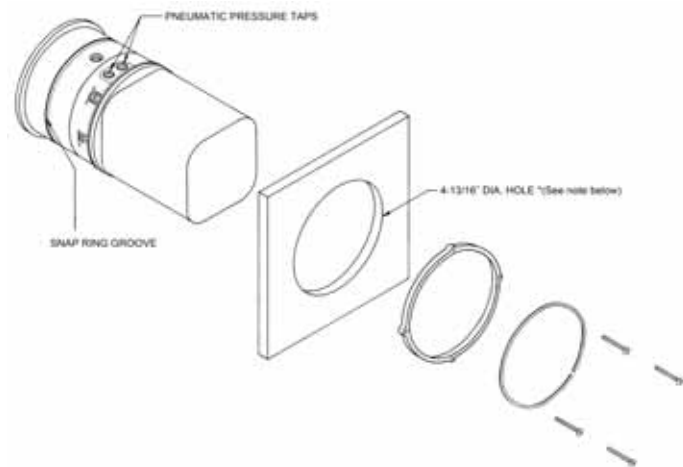

Figure 1

The Capsu-Photohelic® Switch/Gage is a most versatile, precise pressure switch combined with the Capsuhelic® pressure gage. Available with one or two phototransistor actuated relays. Gage reading is unaffected by switch operation. Easy to adjust set points with knob controls. Applied pressure and switch set points are fully visible at all times. Deadband is one pointer width – less than 1% of full scale. Double-pole double-throw relays can be easily interlocked to provide variable deadband control. For positive, negative or differential pressures as low as 0 to .5 in w.c. and as high as 0 to 6000 psig full scale; set points as low as .01 in w.c. on a 5" scale unit.

#### PHOTOHELIC SENSING – HOW IT WORKS

In a typical control application, the Capsu-Photohelic® switch/gage controls between high and low pressure set-points. When pressure changes, reaching either set-point pressure, the beam from an LED to the limiting phototransistor will be cut off by the helix-driven light shield. The resulting signal change is electronically amplified to actuate its DPDT slave relay and switching occurs. Deadband between make and break is 1% of full scale or less – just enough to assure positive, chatter-free operation.



Through Panel Mounting  
Figure 2

\*For convenience, this hole can be made with Model 730E, 120 MM chassis punch manufactured by Greenlee Tool Co. Contact your machine tool distributor. Not available from Dwyer Instruments.

#### SPECIFICATIONS

##### GAGE SPECIFICATIONS

**Service:** Compatible gases and liquids. Brass case option required for water based liquids.

**Wetted Materials:** Consult factory.

**Accuracy:** ±3% of FS at 70°F (21.1°C). ±2% on 43000S models; ±4% on 43215, 43220 and 43500.

**Pressure Limits:** -20 Hg to 500 psig (-0.677 to 34.5 bar).

**Temperature Limits:** 20 to 120°F (-6.67 to 48.9°C). Low temperature option available.

**Process Connections:** 1/4" female NPT.

**Size:** 4" (101.6 mm) dial face, 5" (127 mm) OD x 9-3/16" (233.36 mm).

**Weight:** 5 lb, 8 oz (2.49 kg).

##### SWITCH SPECIFICATIONS

**Switch Type:** Each setpoint has 2 form C relays (DPDT).

**Repeatability:** ±1% of FS.

**Electrical Rating:** 10 A @ 120 VAC, 6 A @ 240 VAC, 60 Hz res. 10 A @ 28 VDC.

**Electrical Connections:** Screw terminals.

**Power Requirements:** 120 VAC, 50/60 Hz; 240 VAC & 24 VAC power optional.

**Mounting Orientation:** Diaphragm in vertical position. Consult factory for other position orientations.

**Set Point Adjustment:** Adjustable knobs on face.

**INSTALLATION**

**1. Location:** All parts of the Capsu-Photohelic® pressure switch/gage are ruggedly constructed and will stand a moderate amount of vibration, physical shock and handling. Normal care in handling and installation is all that is required. In cases where instrument panel vibration is severe, the panel should be mounted or the amplifier-relay unit mounted remotely on a more stable surface.

Select a location where the ambient temperature will not exceed 120°F. Pneumatic pressure sensing lines may be run any necessary distance. For example, 250 foot sensing lines will not affect accuracy but will damp the reading slightly. Do not restrict lines. If pulsating pressure or vibration causes excessive pointer oscillation or relay chatter, consult factory for additional damping means. See accessory Bulletin S-101 for fittings.

**2. Position:** The Capsu-Photohelic® may be mounted as an integral package or the amplifier-load relay assembly and housing may be mounted remotely from the indicating gage-phototransistor unit. Extension cords with 7 pin plugs and receptacles are available from Dwyer for interconnection of the two units.

All standard units are calibrated for use with the diaphragm and scale in a vertical position. Special factory calibration is available for applications requiring inclined or horizontal positions. The exceptions are ranges under 5 in w.c. which are only available for vertical installation.

**3. Mounting:** The Capsu-Photohelic® is normally mounted before making electrical connections, as the electrical enclosure is independent of the mounting means and may be removed at any time.

**A. Panel Mounting:** Normal mounting is flush or through panel as shown in Figure 2. Be sure to allow 4-3/8" extra space behind the unit for electrical enclosure removal. Make a single 4-13/16" diameter hole in the panel. Insert the entire Capsu-Photohelic® unit from the front, then slip on the mounting ring and snap ring from the rear. Seat the snap ring in its groove, back up the mounting ring against snap ring and tighten the four (4) 1-1/4" No. 6-32 clamp screws provided. If behind panel space is critical, the amplifier-relay unit can be mounted remotely. See the Remote-Relay Mounting Instructions for details.

**B. Gage Mounting with Relay Package Remote:** Where it is preferred to install the amplifier-relay unit separate from the gage, (usually due to space limitations) the gage may either be panel mounted as shown in Figure 2 or surface mounted as in Figure 3A. For surface mounting, use the hole layout in Figure 3B.

**CAUTION** When the gage is surface mounted, two 1/4" diameter holes must be located as shown for blow-out protection. This assures that if the gage is overpressured, thus causing a failure, pressure will be safely vented out the back. Failure to keep these holes clear could result in personal injury and/or property damage since the excessive pressure could be forced into the front cover which would then blow off.

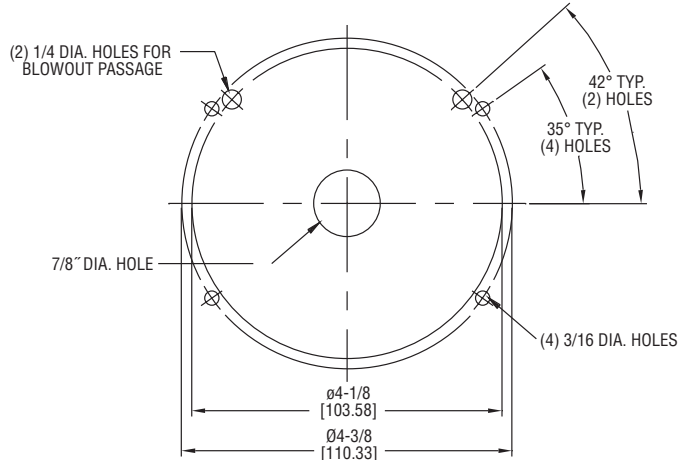

**B: Hole Layout (Front)**

**Figure 3**

**C. Remote Relays Mounting:** The amplifier – relay unit may be mounted remotely as shown in Figure 4A. Use the hole layout as shown in Figure 4B for this option. Additional mounting information for special requirements is available from the factory.

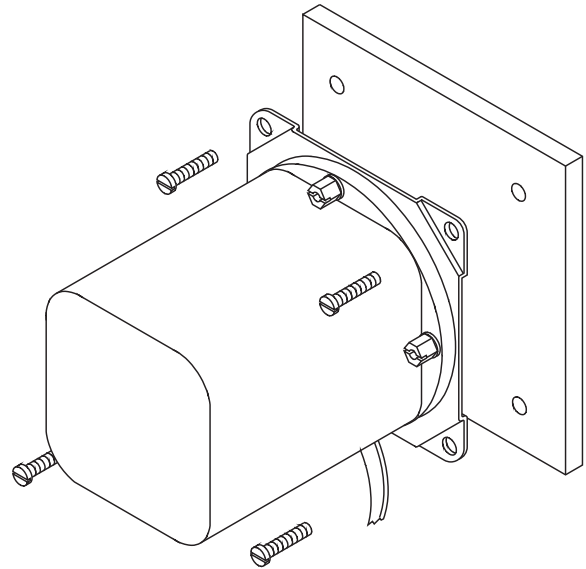

**A: Remote Amplifier-Relay Unit**

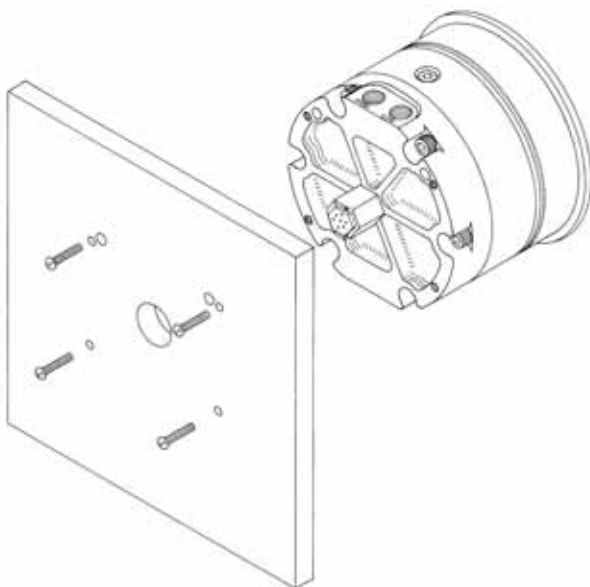

**A: Surface Mounting**

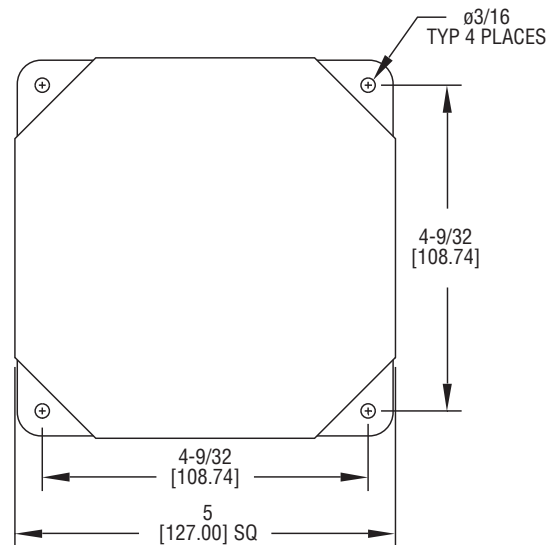

**B: Hole Layout**  
**Figure 4**

**4. Pressure Connections & Zeroing:** After installation, but before making pressure connections, set the indicating pointer exactly on the zero mark by using the zero adjust screw located near the bottom of the front cover. This adjustment must be made with both high and low taps vented to atmosphere.

Make pressure connections to the 1/4" NPT female taps using adapters appropriate for the type of tubing being used. 1/4" OD or larger copper or stainless steel is recommended. Either of the duplicate sets may be used, but normally the upper set is preferred for air or gases and the lower for liquids. This allows condensate to be periodically drained out the bottom on gas service and trapped air to be purged out the top on liquid service. Optional A-314 Bleed Fittings simplify either operation. It is especially important that all air be bled from the gage on liquid service to assure accurate readings.

For differential pressures, use both high and low taps and plug the unused pair. For positive pressure, use either high tap, plug the other, and leave the low side vented to atmosphere. For negative pressure, (vacuum) use either low tap, plug the other, and leave the high side vented to atmosphere. Two 1/4" NPT pipe plugs are furnished with each instrument.

**Note:** If the Photohelic switch/gage is over pressured, pointer may "jump" from full scale back to zero and remain there until the excess pressure condition is relieved. Users should be aware of possible false zero pressure indications under this condition.

**ELECTRICAL CONNECTIONS**

- 1. Cover:** The amplifier-relay unit has an easy to remove housing. Remove the three (3) screws as shown in Figure 5 and slide the housing off. Make all the electrical connections before reinstalling and refastening the housing.
- 2. Conduit:** Electrical access to the connection box portion of the relay housing is by bottom opening for 3/4" conduit. Use of flexible conduit is recommended. It should be supported from the panel or other suitable surface to prevent the wiring system from exerting undue strain on the instrument. See Figure 5.

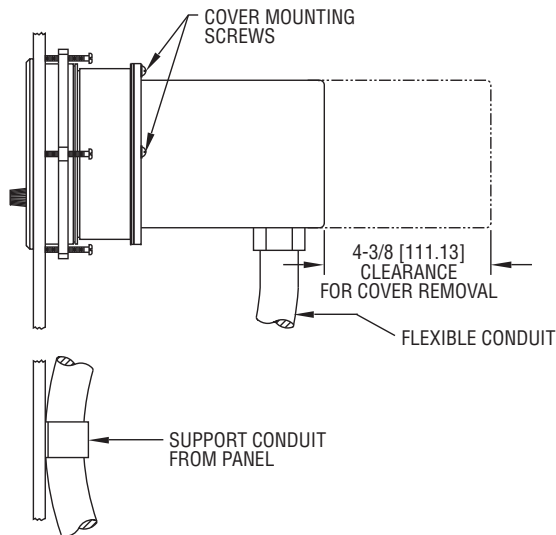

**Terminal Board  
Figure 5**

**3. Terminal or Connection Board Layout:** In Figure 6, "Terminal Board," **Section A** contains the connections for the load or slave relay actuated by the high or right set-point phototransistor. This relay is a double pole, double throw type. The two top connections are normally closed, the two middle connections are normally open, and the bottom connections are the common pair. The relay is in its normal or de-energized position when pressure is below the right hand set-point.

**Section D** is exactly the same as **Section A** except that its load or slave relay is controlled by the low or left set-point. The de-energized position is below the left hand pointer set-point.

**Section B** contains the external connections to the holding coil circuit for the high or right set-point relay and **Section C** contains similar connections for the low or left set-point relay. The function and use of these connections varies somewhat depending on the circuit style of the instrument. See paragraphs 5 and 6 for details.

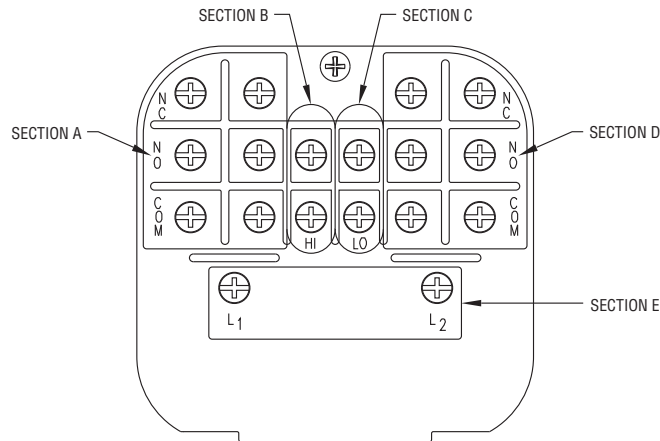

**CAUTION** Do not apply electrical current to terminals in Sections B and C.

**Mounting Details  
Figure 6**

**Section E** contains the power connections for the control unit transformer primary. The transformer in turn supplies reduced voltage power for the LED, phototransistor, amplifier unit and load relay pull in and holding coils. Connections must always be made to this section in order to put the unit in operation. Standard units are designed for 117 VAC input to the transformer. Special units are also available for other voltages.

**Separate Ground Wire** attachment is provided for by a No. 6-32 screw on the mounting bracket near the conduit opening. An additional ground wire connection is located on the side of the gage body for use when the amplifier-relay unit is mounted remotely.

**Single Set-Point** instruments are furnished with the right or high set-point components and circuitry in place. These are connected to Sections A and B of the terminal board. The left or low set-point components are omitted.

- 4. Circuit Style:** The Capsu-Photohelic® is available with several factory installed optional internal circuits. They are identified as to style by a label shown in Figure 7. This label is mounted prominently on the terminal board of each instrument. The letter H denotes a circuit in which the relay can be made to latch or remain energized after pressure increase to its set-point.

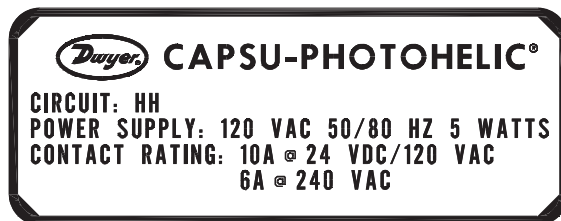

**Circuit Label  
Figure 7**

The letter L denotes a circuit in which the relay can be made to latch or remain de-energized after pressure decrease to its set-point. Two letters are required to fully identify a dual set-point unit. Thus, circuit style HH, which is standard, is a dual set-point circuit which has provisions for latching on pressure increase to either set-point. Single relay units are identified by the letters SR followed by H for the standard unit or L for the special low latch unit. Units for use with other than standard 117 VAC will be so indicated on the label.

- 5. Dual Set-Point Automatic Reset:** Circuit Style HH is used for simple on-off switching applications. To place in service, connect load circuits to the appropriate terminals in Section A (Figure 6) for the right set-point and Section D for the left set-point. Note that the N.O. contacts are open when the gage pressure pointer is to the left of the set-point pointers. No connections are necessary in Sections B and C. Make external ground connections as required and connect power to Section E for the control unit. To use circuit style LL for automatic reset, a jumper wire must be installed between the upper and lower terminals in Sections B and/or C.

**6. Dual Set-Point Manual Reset:** Circuit Style HH may also be used for manual reset applications where it is desired to have maintained contact on either relay following pressure increase above its set-point. Load or signal connections are made to the appropriate terminals in Sections A and D (as in paragraph 5 above). Connect terminals in Sections B and C through normally closed switches or push buttons as shown in Figure 8. Use of "dry-circuit" type switches such as Dwyer Part No. A-601 with paladium, gold, etc. or rotary wiping action type contacts is recommended. Make external ground connections as required and connect power to Section E for the control unit.

Circuit Style LL is used for manual reset applications which require that contact be maintained following pressure decrease below the set-point. Load connections are made to the appropriate terminals in Sections A and D. A normally open type manual reset switch such as Dwyer Part No. A-601 is connected to the terminals in Sections B and C. The circuit must be "armed" by momentarily closing the switch while the black pointer is to the right of the set-point. From that point on, the circuit will latch on pressure decrease below the set-point and remain latched on pressure increase until manually reset with the optional switch.

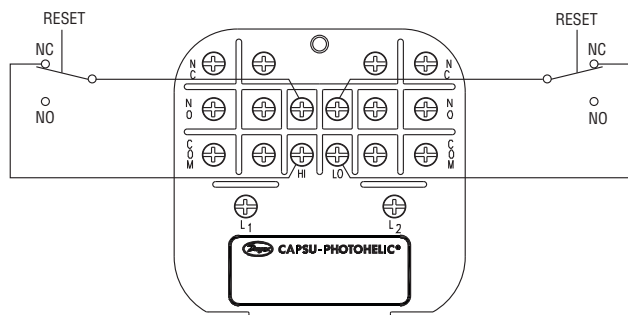

**CAUTION** Do not apply electrical current to terminals in Sections B and C.

**Manual Reset with Circuit HH**  
Figure 8

**7. Dual Set-Point Automatic and Manual Reset Combinations:** Circuit Style HH may be used with either set-point wired and operating as in paragraph 5 above and other set-point wired and operating as in paragraph 6.

**8. High Low Limit Control – Dual Set-Point:** Circuit Style HH may be used to control fans, dampers, pumps, etc., between the set-points of a Capsu-Photohelic®. To accomplish this, use one set-point relay to reset the other as shown in the wiring diagram Figure 9. In this typical application, the load (for instance a fan) would be connected to the N.C. contacts for the right set-point relay, Section A (Figure 6). On pressure rise to the right set-point, its relay would pull in and hold even though pressure might then fall below that set-point. If the pressure continued to fall to the left set-point, its relay would automatically be DE-ENERGIZED, return to its normal position and in so doing, open the holding coil circuit from Section B (Figure 6). The right set-point relay would thus be reset and the cycle could repeat.

**9. Dual Set-Point Special Purpose Circuits:** Circuit Style LL may be used where manual reset following maintained contact on pressure decrease to either set-point is desired. Circuit Styles HL and LH are combination units. For special combinations of features, special units, and detailed instructions regarding their use, consult the factory.

**10. Single Set-Point Photohelic®:** The single set-point Capsu-Photohelic® is furnished with the right set-point only. Terminals in Section A and B (Figure 6) are connected to this relay. Circuit Style SRH is wired for automatic reset as in paragraph 5 above. Manual reset is accomplished by adding a normally closed reset switch or push button to the circuit as described in paragraph 6 above.

**11. Single Set-Point Special:** Manual reset after actuation on falling pressure can be obtained by using Circuit Style SRL. Consult the factory for special units and detailed instructions regarding their use.

**12. Placing in Service:** In normal operation each relay is de-energized when the pressure applied to the instrument is below its set-point. Special low-latching units will ordinarily have to be reset before placing on the line in normal operation.

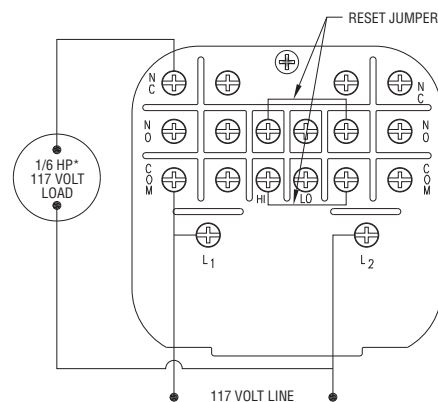

\*Note: For larger motors, use the Capsu-Photohelic® in a maintained contact, 117 Volt Control or Push Button Circuit of the motor starter.

**High-Low Limit Control**  
(Circuit HH)  
Figure 9

**13. Failure Mode:** The Capsu-Photohelic® circuit design provides certain protection in the event of a loss of pressure or electrical power. In either case, both relays will de-energize, returning to their normal "zero pressure" state. The exceptions to this are models with center zero ranges. Because the relays on all standard models are always energized when the indicating (black) pointer is to the right of their respective set-points, the relay action on loss of pressure will depend on set-point position, since either of them could be located to the left of zero. As an example; if the left pointer were set at -2 in. w.c. and negative pressure was -3 in. w.c., a loss of that pressure would allow the black pointer to return to the center and thus cause the low set-point relay to energize.

If the LED should fail, only the left-low relay will de-energize. The right-high relay will react as if pressure were above its set-point and will remain energized even though pressure might be below that setting. In this situation, only termination of electrical power will allow the right-high relay to de-energize.

#### MAINTENANCE/REPAIR

Upon final installation of the Series 43000 Capsu-Photohelic® Switch/Gage, no routine maintenance is required. The Series 43000 is not field serviceable and should be returned if repair is needed (field repair should not be attempted and may void warranty).

#### WARRANTY/RETURN

Refer to "Terms and Conditions of Sales" in our catalog and on our website. Contact customer service to receive a Return Goods Authorization number before shipping the product back for repair. Be sure to include a brief description of the problem plus any additional application notes.





Exploded View

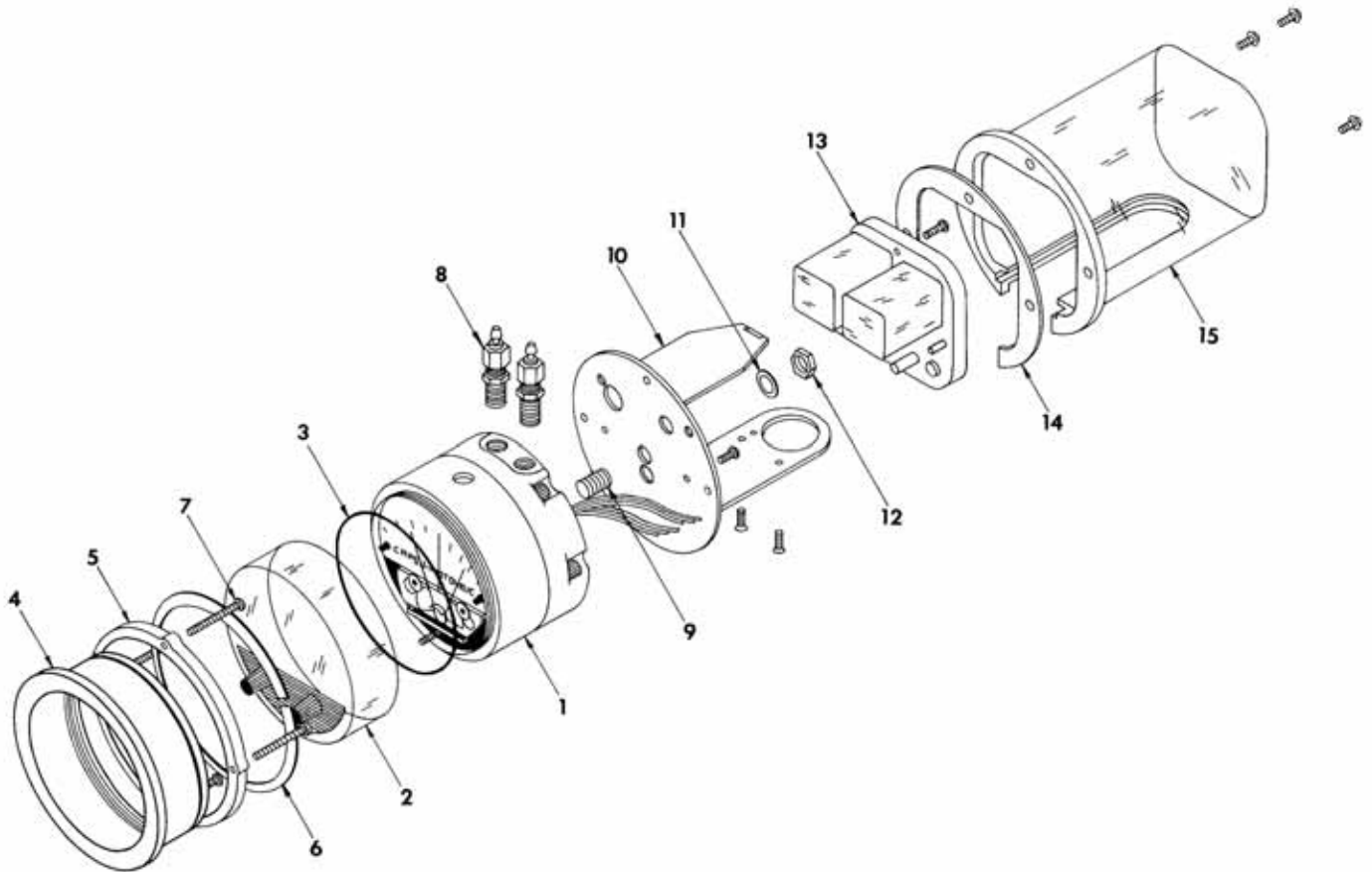

Figure 10

- |   |   |
|---|---|
| <ul style="list-style-type: none"> <li>1. Capsu-Photohelic® Gage Body &amp; Sensor Assembly</li> <li>2. Cover, Knob and Zero Adjust Assembly</li> <li>3. "O" Ring Seal for Cover</li> <li>4. Bezel with Groove for Snap Ring</li> <li>5. Mounting Ring</li> <li>6. Snap Ring (Mounting)</li> <li>7. Screws for Mounting Ring, #6-32 x 1-1/4" RHMS, (4) Required</li> <li>8. Optional A-314 Bleed Fitting, 1/4" NPT</li> </ul> | <ul style="list-style-type: none"> <li>9. 1/8" NPT Mounting Stud</li> <li>10. Flange Plate and Bracket Assembly for Circuit Board with Mounting Screws</li> <li>11. Lock Washer</li> <li>12. 1/8" NPT Mounting Nut</li> <li>13. Amplifier-Relay Circuit Assembly</li> <li>14. Gasket for Housing</li> <li>15. Housing for Amplifier-Relay Unit with (3) #6-32 x 5/16" RH Machine Screws</li> <li>16. 1/4" NPT Pipe Plugs (Not Shown)</li> </ul> |
|---|---|

When corresponding with the factory regarding Capsu-Photohelic® switch/gage problems, refer to the call-out numbers in this view. Be sure to include range, single or double circuit and circuit style letters where required. Field repair is not recommended; contact factory for service information.