

RABO[®] Rotary Gas Meter

.....
Instruction Manual

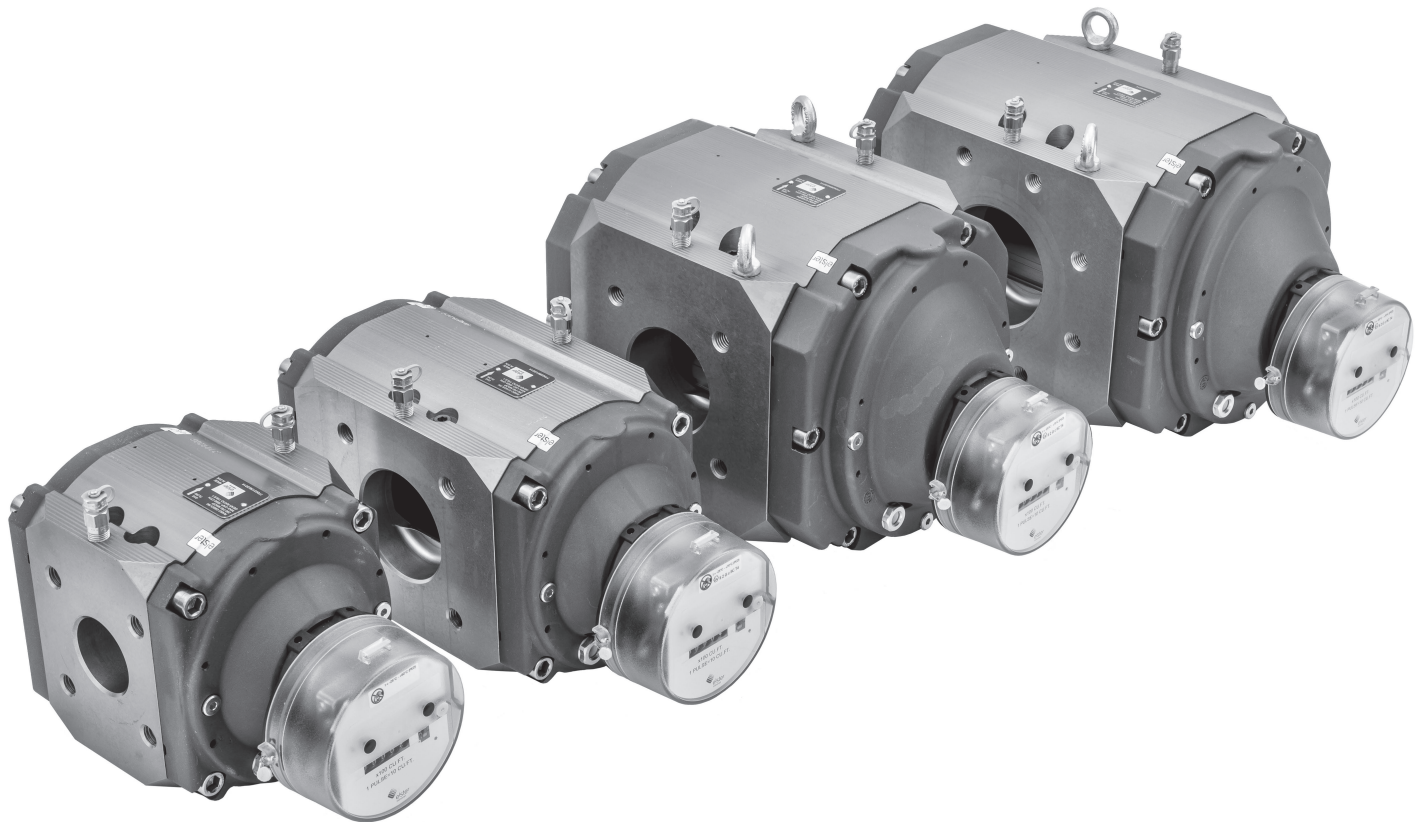

Honeywell
THE POWER OF **CONNECTED**

RABO® Rotary Gas Meter

Table of Contents

| | |
|------------------------------------|----|
| 1. General Information | 3 |
| 2. Intended Use and Application | 3 |
| 3. Operating Principle | 3 |
| 4. Receiving, Handling and Storage | 4 |
| 5. Installation | 4 |
| 6. Start-up/Commissioning | 6 |
| 7. Decommissioning and Removal | 6 |
| 8. Inspection and Maintenance | 6 |
| 9. Testing | 6 |
| 10. Technical Data | 8 |
| 11. Index | 9 |
| 12. Pulser | 11 |
| 13. Thermowell | 12 |
| 14. Instrument Drive (ID) | 12 |
| 15. Auxiliary Equipment Mounting | 14 |
| 16. Troubleshooting | 15 |

1. General Information

This manual covers the installation, operation and maintenance for the Elster Instromet RABO Rotary Meter. Refer to EAM-TB5900 for additional information.

2. Intended Use and Application

Elster RABO meters are suitable for measuring most types of clean, dry, non-corrosive common gases. They are NOT intended for use on biogas, sewage gas, oxygen, acetylene or liquids of any kind. Product life and measurement accuracy can be affected by contamination in the gas stream. Periodic servicing will prolong the life and performance of the meter.

3. Operating Principle

The RABO meter utilizes positive displacement principle of operation which makes volumetric measurements by displacing finite volumes of gas. The positive displacement occurs within a cavity formed between the meter's internal housing and its rotating impellers. The counter-rotating "figure-8" impellers [Figure 1] turn as a result of pressure drop across the meter's inlet and outlet created as downstream gas is consumed. The rotating impellers separate the flowing gas into small, finite volumes and are counted using a mechanical index. The RABO meter has no wearing parts because precision clearances between the impellers and meter body are maintained by timing gears, which are designed to enhance long term accuracy. Combining adequate filtration and periodic maintenance, a RABO meter will remain accurate over many years.

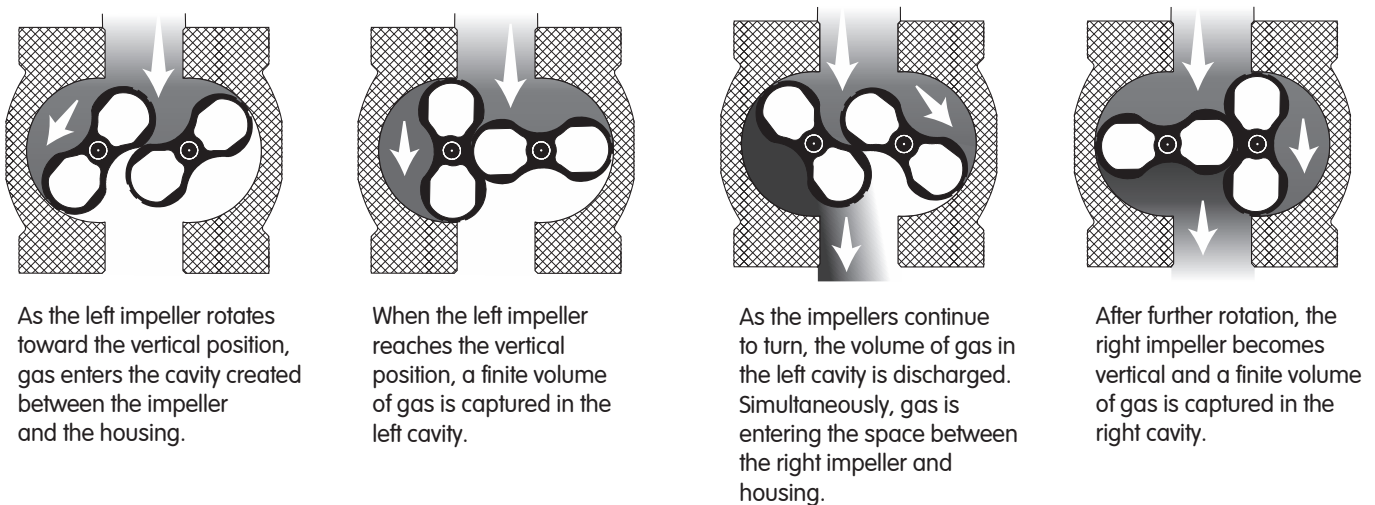

Figure 1. Operating Principle

4. Receiving, Handling and Storage

Elster RABO meters should be handled with care to protect the product from damage. If the package shows evidence of damage through mishandling in transit, you should notify the shipper immediately, file a claim with the carrier and notify your Elster supplier.

Damage to internal components may occur without visible external damage. All new meters should be inspected and checked for free rotation of the impellers by lightly blowing into the inlet of the meter. This slight air pressure should cause the impellers to rotate freely and come to a stop slowly.

NOTICE

DO NOT attempt to make any repairs. Tampering with the meter may void warranty coverage.

If a meter shows signs of external damage, or if the impellers do not rotate freely, contact your local Elster sales representative for return instructions.

Elster RABO meters are supplied with oil in a separate container. A material safety data sheet (MSDS) is available upon request. DO NOT put oil in the meter until it is installed and leveled in the gas piping system. Meters containing oil that are transported or not installed level may lead to contamination of the measurement chamber, and will impact accuracy.

Store Elster RABO meters in their original shipping container in a dry location until installation. If prolonged storage is experienced, RABO meters should be tested for accuracy before installation.

5. Installation

Elster RABO meters can be installed in horizontal or vertical (top inlet) piping configurations. Vertical (top inlet) piping is preferred because it enables the meter to pass contaminants more freely through the meter. All piping should be properly supported and aligned to eliminate any strain on the meter, which may cause the impellers to bind.

Recommended piping practices include a filter or strainer on the inlet of the meter and non-lubricated isolation valves. A bypass line will facilitate maintenance and removal of the meter and provide uninterrupted gas supply.

The meter should not be installed lower than the outlet pipe run. If it is necessary to install the meter lower than the outlet pipe run, installation of a drip leg in the outlet piping to capture condensate is recommended. The meter should never be located at the lowest point in the system.

A restricting orifice can also be installed at least 4 pipe diameters downstream of the outlet of the meter to prevent the meter from flowing excess capacity. Warranty does not cover failures due to excess flow conditions.

a) Piping Configurations [Figures 2, 3 and 4]

NOTICE

DO NOT weld piping while meter is installed in the piping system.

NOTICE

If hydro testing, remove the meter from the piping system.

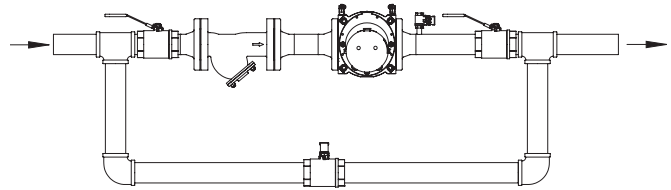

Figure 2. Horizontal installation, side view

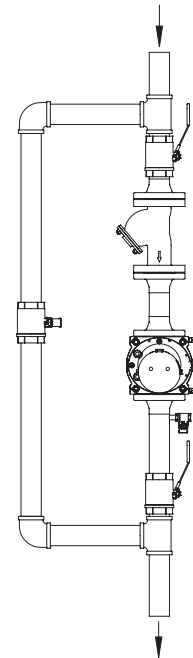

Figure 3. Vertical installation, side view

b) Mounting

- 1) Always follow your company's procedures, and applicable local codes and ordinances.
- 2) Ensure gas valves are closed.
- 3) Ensure the upstream piping is clean and free of any debris.
- 4) Remove protective caps from meter inlet and outlet prior to installation.
- 5) Ensure the impellers turn freely.
- 6) Ensure the direction of flow using the arrow on the nameplate.
- 7) Ensure the meter orientation is correct. Impeller shafts must be horizontal [Figure 4].

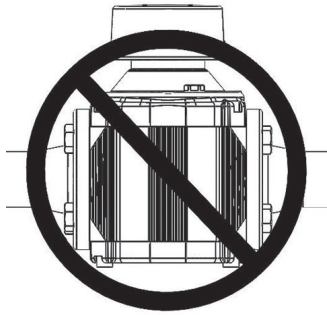

Figure 4. Side view

- 8) Connect the inlet and outlet pipe flanges using appropriate bolts and gaskets. Inlet and outlet pipe flanges should be parallel and should not introduce any bind on the meter body when tightened.
- 9) Level meter to within 1/16" per foot in all directions and tighten flange bolts evenly (maximum 80ft-lbs).

c) Adding Oil



Add oil only to the index end of the meter.

- 1) Ensure gas valves are closed and meter and piping are depressurized.



Failure to depressurize the meter prior to removing meter and/or components could result in personal injury and/or property damage.

- 2) Remove oil fill plug in the counter end case cover using a 5mm hex key [Figures 5 and 6].
- 3) Using the supplied syringe and oil, slowly add oil until it is $\pm 1/16"$ of the center of the sight glass [Figure 7]. **DO NOT OVERFILL.** Only use Shell Morlina lubricating oil.



DO NOT remove any sight glasses. No maintenance can be performed through these openings.

- 4) Reinstall the oil fill plug.

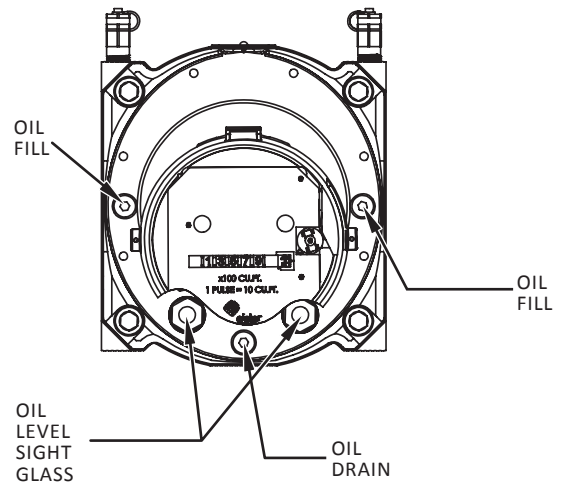

Figure 5. Horizontal installation

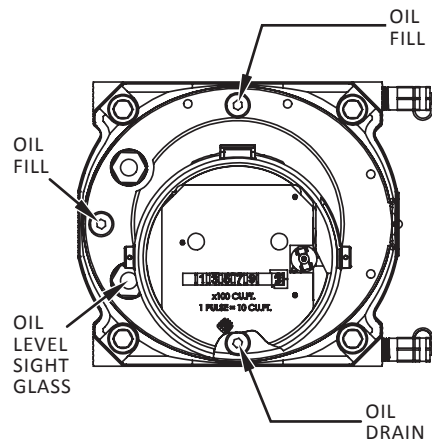

Figure 6. Vertical installation

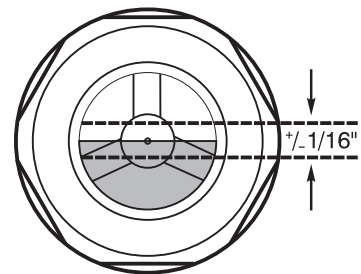

Figure 7. Sight glass

6. Start-up/Commissioning

After the meter has been properly installed, it is important to use extreme care during start-up to mitigate adverse conditions that can damage the meter.

- Ensure that the maximum operating pressure of the meter will not be exceeded.
- Always follow your company's procedures, and local codes and ordinances.
- With the meter run's inlet and outlet valves closed, open the bypass valve and pressurize the piping system.
- With the meter outlet valve closed, slowly open the meter inlet valve not to exceed 5 psig per second until pressure is equalized throughout the meter piping system. Rapid pressurization can cause an over-speed condition and can damage the meter. Damage will not be covered under warranty. When the meter piping system pressure is stabilized, open the inlet valve completely.
- Slowly open the meter's outlet valve until the meter starts to operate at low speed. Meter speed can be seen through the view port located on the back of the meter (Figure 8).

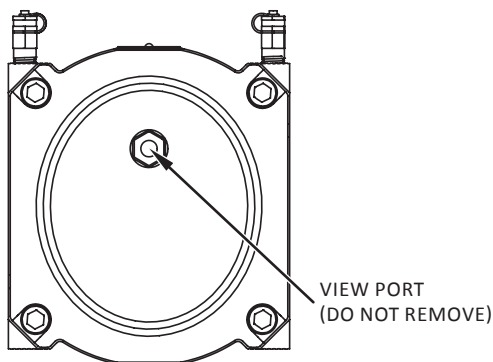

Figure 8. Back of meter

- Operate the meter at low flow for 1 to 2 minutes to verify proper operation. If the index does not start registration, or if you hear knocking or scraping sounds coming from the meter, stop the flow and follow appropriate decommissioning procedures before removing the meter from the line.
- If operation is satisfactory, gradually open the meter's outlet valve to the full open position.
- Slowly close the bypass valve.
- Check the meter connections for leaks using common industry practices.
- Clock the meter (see Index section 11c) to confirm the flow rate is not exceeding the maximum capacity of the meter.
- Perform and record the meter's differential pressure (see Testing section 9b).

7. Decommissioning and Removal

- Always follow your company's procedures, and local codes and ordinances.
- Slowly open bypass valve.
- Slowly close the meter's outlet valve, then the inlet valve.
- Slowly, completely depressurize the meter piping.

! WARNING

Failure to depressurize the meter prior to removing meter and/or components could result in personal injury and/or property damage.

- Drain oil from the index end case cover and dispose of the oil in accordance with applicable regulations.
- If removing the meter from the piping system, loosen flange bolts. Ensure meter is properly supported before removing bolts completely.

8. Inspection and Maintenance

It is recommended to inspect Elster RABO meters periodically to help ensure accurate performance over a long period of time. Maintenance intervals can be derived from inspection criteria.

Routine inspections should include:

- Checking to ensure the meter is level in all planes
- Listening for abnormal sounds in the meter
- Checking oil level and clarity — oil should be red and clear
- Checking index movement if gas is flowing
- Checking for leaks
- Testing the meter's differential pressure

Routine maintenance should include:

- Changing the oil if the color becomes dark
- Adding oil if the color is red and clear, but below the recommended level

9. Testing

Elster RABO meters should be tested in accordance with applicable governing standards. The accuracy of a meter can only be determined by comparing results to a traceable reference, typically a sonic nozzle, bell, piston or transfer prover. Accuracy may be done on site using transfer provers, and typically requires removal for testing with other technologies.

Differential pressure testing is a method of determining whether the performance of a rotary meter may have changed over time, and can be done on site while the meter is operating under pressure. Baseline data must be captured during initial start-up to which future data can be compared.

a) Proving

When testing a meter on a prover, the meter temperature, pressure and volume are necessary inputs for the proving device. The meter temperature is obtained by a temperature probe installed near the inlet of the meter. A thermowell can be installed in the meter run piping or on the meter itself to facilitate installation of the temperature probe. The meter pressure should come from the meter differential pressure taps.

Pressure test ports are provided for simplified pressure connections [Figure 9].

! WARNING

Below 45°F the neoprene core of the Pressure test ports does not recover its original shape as rapidly as it would at temperatures above 45°F. Therefore, upon removal of the probe used for pressure or temperature readings, the valves may not close fully and immediately or the valves may remain slightly open until the operating temperature is above 45°F. Duration of probe insertion and pressure are also factors in the rate of valve closing. For this reason, plugs should not be used in applications where discharging gas or liquids would create a hazard. The gasketed cap is supplied to eliminate the small amount of leakage that may occur at lower temperatures after probe insertion and removal. The cap should be left on the plug at all times and tightened to deter unauthorized removal. Special care should be taken to assure that readings are taken in the shortest space of time and that a probe is never left in a plug for a period of hours or days. Severe deformation of the valves may occur if the probe is left in the plug for a long period of time.

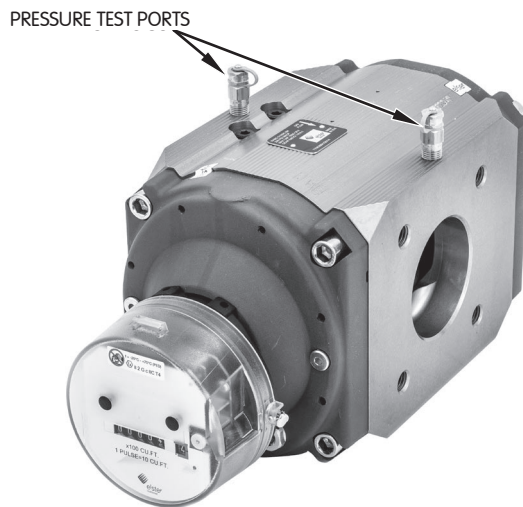

Figure 9. Pressure test ports

Typically, when proving a meter, both the meter pressure and meter differential pressure are used and recorded. The RABO meter differential pressure ports are not full bore and most temperature probes will not fit through into the gas stream. Installing the temperature probe in the provided thermowell ports is recommended.

The meter volume is determined through a device that senses the meter revolutions. An optical pickup can be used on the index proving wheel or an index pulser may be used.

On-site proving, performed in-line, also requires connections that allow air flow through the meter to the prover. This is accomplished by use of pipe Tees upstream and downstream of the meter. A bypass loop is recommended for uninterrupted gas supply to the customer.

While performing an accuracy test, the meter is tested for a specified volume of gas at each flow rate test point. Poor repeatability at a given rate may be caused by a test volume that is too small. If the meter does not repeat within acceptable limits (0.1%), try increasing the test volume and retesting the meter. Most companies have developed test plans that include the volume of gas for each size meter at a given flow rate. Consult your Elster representative for applicable volumes.

b) Differential Pressure Testing

A differential pressure test is not an accuracy test, but it can be used to gauge the relative performance of the meter.

Rotary meters are made from solid parts, machined to tight tolerances with close clearance fits, and the energy it takes to turn the meter is generally used to overcome the friction of the bearings and other rotating parts. If this friction value increases, it will take more energy to overcome it. This additional energy is measured as an increased pressure drop across the meter.

The increased friction is caused by contamination of the measuring chamber and/or bearings.

Contamination in the measuring chamber can cause the meter components to wear against each other. Contamination in the bearings makes them harder to turn.

Comparing the pressure drop reading when the meter is new to the reading collected after time allows the performance to be monitored.

RABO meters are supplied with Pressure test ports installed in the meter differential pressure ports [Figure 9]. This facilitates differential meter testing. A differential pressure test is performed using a differential pressure manometer. The test is to measure the pressure drop across the meter at a given flow rate, under known operating conditions at a known date and time.

The meter differential curve of flow rate vs pressure is not linear. Testing at multiple flow rates is suggested. It is preferable to test at 3 rates between 25% and 100% of flow if possible. Differential pressure tests at flow rates under 25% are hard to interpret because the meter differential pressure at the lower flow rates is quite small. The error in measurement is almost as large as the reading itself.

The meter differential pressure is also a function of line pressure and increases as line pressure increases. Testing the meter at the same conditions (line pressure and flow rates) yields comparable data.

A change in the differential pressure indicates a change in performance. Testing has shown that a 50% increase in meter differential pressure (at flow rates over 25%), indicates almost a 1.0% change in meter accuracy.

Baseline data must be captured during initial start-up to which future data can be compared.

If the differential pressure test shows an increase in the meter pressure drop at a given flow rate of more than 50% from the original value (1.5 x original value), then it is recommended that the meter be removed and serviced.

The frequency of differential testing is at the discretion of the user.

10. Technical Data

a) Performance

| | Units | 3.5M/G65 | 5.5M/G100 | 9M/G160 | 14M/G250 |
|---|---------------------------|-------------|-------------|-------------|-------------|
| Rangeability | | 90:1 | 160:1 | 160:1 | 160:1 |
| Start Rate | acfh [am ³ /h] | 1.3 [0.04] | 0.9 [0.03] | 2.5 [0.07] | 2.5 [0.07] |
| Stop Rate | acfh [am ³ /h] | 1.1 [0.03] | 0.8 [0.02] | 1.9 [0.05] | 2.3 [0.07] |
| Flow Rate at ½" w.c. DP, Gas | acfh [am ³ /h] | 2,715 [77] | 4,074 [115] | 5,722 [162] | 6,740 [191] |
| Differential Pressure at 100% Flow Rate | in.w.c. [mBar] | 1.46 [3.64] | 1.23 [3.06] | 1.70 [4.23] | 2.65 [6.60] |

Note: Values are for air, except Flow Rate at ½" w.c. DP, which are natural gas values.

b) Sizing Chart

Using the chart below, select the appropriate meter by using the Maximum Instantaneous Flow Rate (scfh) and the Minimum Operating Pressure (psig) at any given point in time.

Example: A flow rate of 25,000 scfh and an operating pressure range of 75–100 psig would require a 5.5M meter based on a 75 psig minimum inlet pressure.

| Model | 3.5M/G65 | 5.5M/G100 | 9M/G160 | 14M/G250 |
|-------------|---|-----------------|-----------------|-----------------|
| psig [Barg] | Corrected Capacity in scfh [sm ³ /h] | | | |
| 0.25 [0.0] | 3,500 [100] | 5,500 [160] | 9,000 [250] | 14,000 [400] |
| 2 [0.1] | 3,900 [110] | 6,100 [170] | 10,000 [280] | 15,600 [440] |
| 5 [0.3] | 4,600 [130] | 7,200 [200] | 11,900 [340] | 18,400 [520] |
| 10 [0.7] | 5,800 [160] | 9,100 [260] | 14,900 [420] | 23,200 [660] |
| 20 [1.4] | 8,200 [230] | 12,800 [360] | 21,000 [590] | 32,700 [930] |
| 30 [2.1] | 10,500 [300] | 16,600 [470] | 27,100 [770] | 42,200 [1,190] |
| 40 [2.8] | 12,900 [370] | 20,300 [570] | 33,200 [940] | 51,700 [1,460] |
| 50 [3.4] | 15,300 [430] | 24,000 [680] | 39,300 [1,110] | 61,200 [1,730] |
| 60 [4.1] | 17,700 [500] | 27,800 [790] | 45,500 [1,290] | 70,700 [2,000] |
| 75 [5.2] | 21,200 [600] | 33,400 [950] | 54,600 [1,550] | 85,000 [2,410] |
| 100 [6.9] | 27,200 [770] | 42,700 [1,210] | 69,900 [1,980] | 108,700 [3,080] |
| 150 [10.3] | 39,100 [1,110] | 61,400 [1,740] | 100,400 [2,840] | 156,300 [4,430] |
| 175 [12.1] | 45,000 [1,270] | 70,700 [2,000] | 115,700 [3,280] | 180,000 [5,100] |
| 250 [17.2] | 62,800 [1,780] | 98,700 [2,790] | 161,500 [4,570] | 251,300 [7,120] |
| 290 [20.0] | 72,300 [2,050] | 113,700 [3,220] | 186,000 [5,270] | 289,300 [8,190] |

Note: All capacities based on 14.4 psia atmospheric pressure, 14.73 psia base pressure, and 60°F base temperature.

c) Dimensions and Weights

| | Units | 3.5M/G65 | | 5.5M/G100 | | 9M/G160 | | 14M/G250 | |
|-----------------|-----------|-----------------------|-------|-----------|-------|-----------------------|-------|-----------|-------|
| A | in. [mm] | 6.75 | [171] | 6.75 | [171] | 9.5 | [241] | 9.5 | [241] |
| B | in. [mm] | 7.56 | [192] | 7.56 | [192] | 10.08 | [256] | 10.08 | [256] |
| C | in. [mm] | 8.63 | [219] | 8.63 | [219] | 10.75 | [273] | 10.75 | [273] |
| D | in. [mm] | 3.78 | [96] | 5.43 | [138] | 5.16 | [131] | 6.14 | [156] |
| E | in. [mm] | 7.52 | [191] | 9.17 | [233] | 10.67 | [271] | 11.65 | [296] |
| F | in. [mm] | 11.26 | [286] | 14.61 | [371] | 15.83 | [402] | 17.76 | [451] |
| G | in. [mm] | 3.78 | [96] | 3.78 | [96] | 5.04 | [128] | 5.04 | [128] |
| Nom. Pipe Size* | in. [mm] | 2 | | 3 | | 3 | | 4 | |
| Bolt Size, H | | 5/8" - 11 | | 5/8" - 11 | | 5/8" - 11 | | 5/8" - 11 | |
| # Bolts/Flange | | 4 | | 4 | | 4 | | 8 | |
| Bolt Circle, J | in. [mm] | 4.75 | [121] | 6.00 | [152] | 6.00 | [152] | 7.50 | [191] |
| Shipping Weight | lbs. [kg] | 29.8 | [14] | 37.7 | [17] | 73.9 | [34] | 82.3 | [37] |
| Carton Size | in. | 18.3L x 10.6W x 12.6H | | | | 23.6L x 13.0W x 13.4H | | | |
| | [mm] | 465L x 270W x 320H | | | | 600L x 330W x 340H | | | |

*ANSI Class 125/150 flat face flange connection

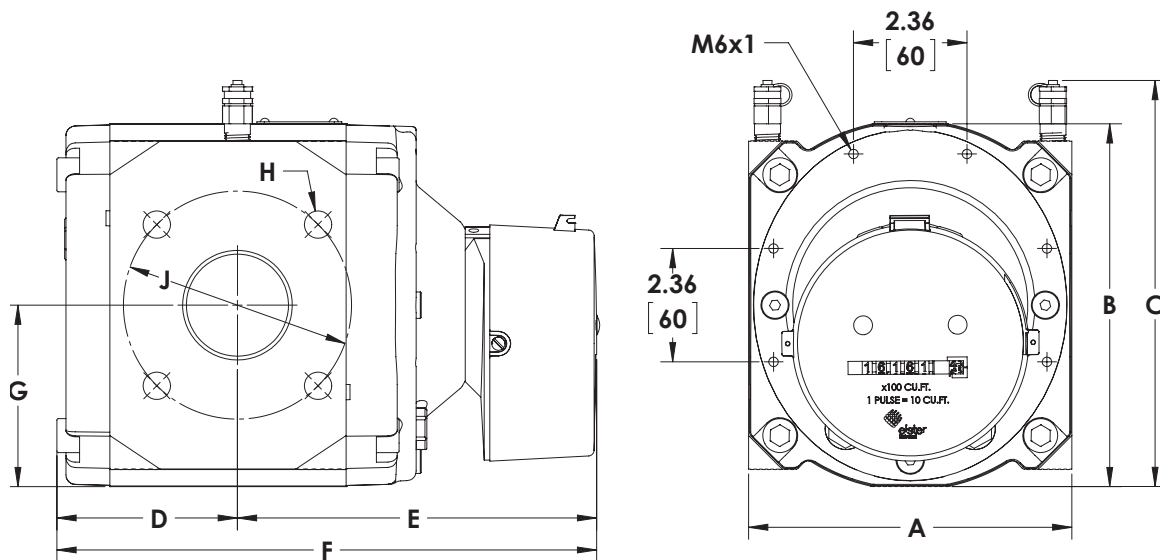

11. Index

All RABO meters are equipped with a non-resettable totalizing odometer-style index that displays volume in actual cubic feet. The index is sealed by an ultraviolet-resistant Lexan cover, requires no maintenance and is completely isolated from gas pressure.

b) Rotatable

The RABO index can rotate 355 degrees to facilitate desired reading angle, depending on the installation orientation. To rotate, simply grasp the index with both hands and turn to the desired position.

b) How to Read

The odometer index is masked to expose the desired digits and units of measure to meet individual requirements. On all meters, the right-most digit will be highlighted with a red square on the index mask, and will always increment in cubic feet. This digit is typically not included in the meter read and is primarily used to indicate flow rate.

When reading an odometer, record all the digits except the digit surrounded by the red square on the index mask, and multiply it by the factor shown on the index face plate. In the example on the next page, the reading would be 1357900 cubic feet. [Figure 10].

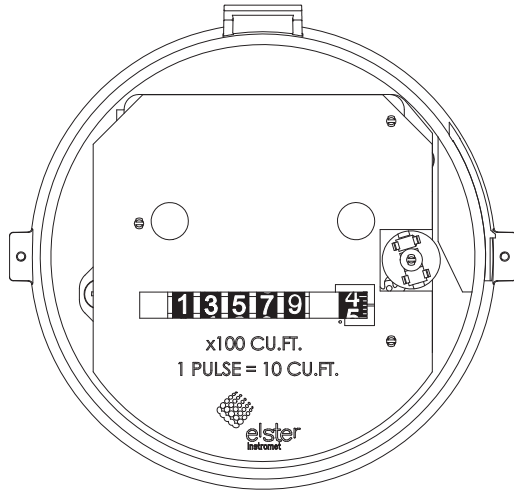

Figure 10. Index

c) How to “Clock” a Meter

The odometer index can be used to calculate the instantaneous flow rate by using the right-most digit (test dial). Each number on this dial represents one (1) cubic foot, and one complete revolution of this dial represents ten (10) cubic feet. You will need a stop watch or a watch with a sweep second hand to calculate flow rate.

1. Measure the time, in seconds, that it takes the test dial to make one complete revolution (10 cubic feet).
2. Use the following formula to calculate flow rate:

$$\text{Flow Rate (acfh)} = (10 \div \text{“time”}) \times 3600$$

Note that the odometer index does not compensate for elevated pressure or temperature. Correction factors will need to be applied to adjust the flow rate to standard conditions (scfh).

d) Removal, Installation and Replacement

Steps to replace the RABO meter index:

1. Cut the seal wires and remove from the holes [Figure 11].
2. Remove (unscrew) the two brass screws on the sides of the index cover [Figure 11].

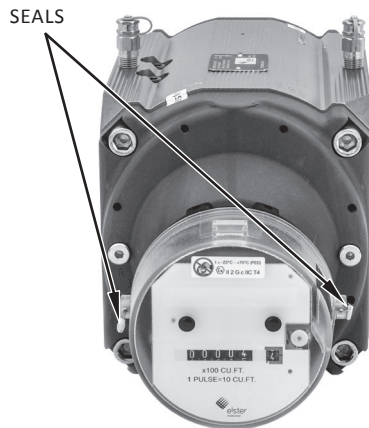

Figure 11. Index cover seals

3. Pull off the index cover.
 - It helps to rock it slightly.
 - Be careful not to damage the masking plate and index when removing the cover.
4. Carefully pull off the index masking plate [Figure 12].

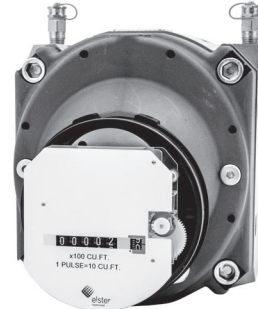

Figure 12. Index masking plate

5. Remove the three index retaining screws using a Torx T20 driver [Figure 13].

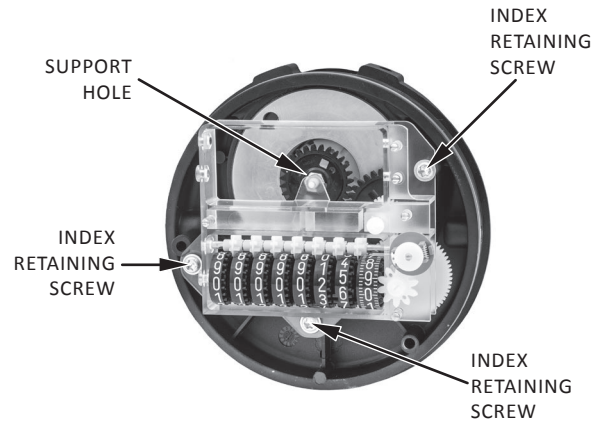

Figure 13. Index retaining screws

6. Carefully remove the index.
 - Pay attention to the driven magnet — it is supported by the index.
 - Leave the magnet on the meter.
7. Transfer the change gear from the damaged index to the replacement [Figures 14 and 15].
 - Remove the change gear on the damaged index.
 - Pry the locking collar off with a knife blade or other sharp object.
 - Unscrew the change gear.



Each meter size uses a common index that has unique colored gears. Interchanging colored gears will result in inaccurate readings. Ensure the replacement index has the same color gears. [Refer to Table 1]

- If the replacement index has a change gear, remove and discard it.
- Attach the change gear from the damaged index to the same shaft on the replacement index.
 - Secure gear on shaft.
 - Snap on the locking collar.

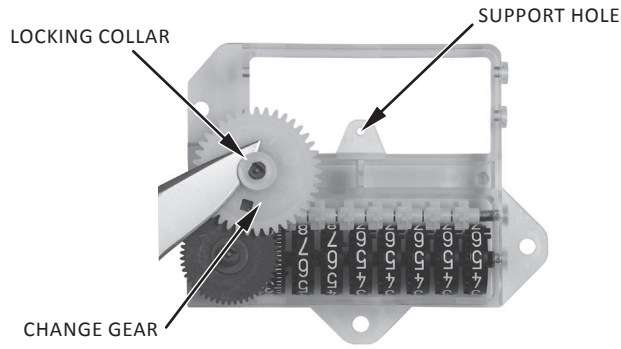

Figure 14. Change gear removal

| Meter | Gear Color |
|-----------|------------|
| 3.5M/G65 | White |
| 5.5M/G100 | Dark Green |
| 9M/G160 | Green |
| 14M/G250 | Red |

Table 1

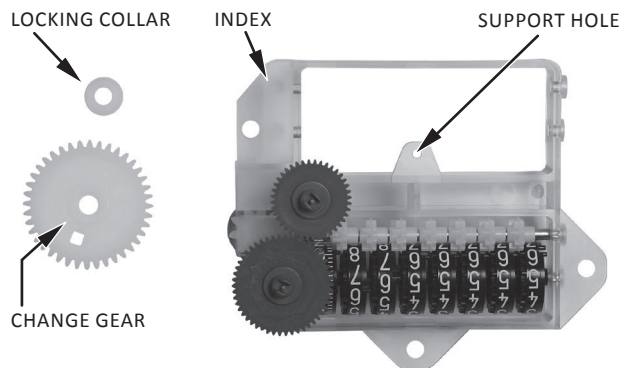

Figure 15. Index, change gear and locking collar

8. Install the replacement index.
 - Orient the index so the mounting holes line up with the posts in the base plate.
 - Carefully ensure the shaft on the magnet holder is in the support hole on the index frame [Figure 13].
 - Install the three screws to retain the index to the base plate. Tighten to snug.
9. Install index masking plate.
10. Install index cover.
11. Install security seals.

12. Pulsar

All RABO meter indexes can be easily outfitted with a pulse output device to interface with auxiliary equipment. Installation of a pulsar is quick and easy, and requires no disassembly. To install a pulsar, simply slide the pulsar into the slot on the index cover [Figure 16], and connect the wires to the desired auxiliary devices [Figure 17]. The pulsar can be secured to the index cover screw with a seal wire to mitigate and indicate tampering.



WARNING

Explosion Hazard
 Auxiliary equipment and interconnecting wiring must be in accordance with local and national codes for hazardous areas.

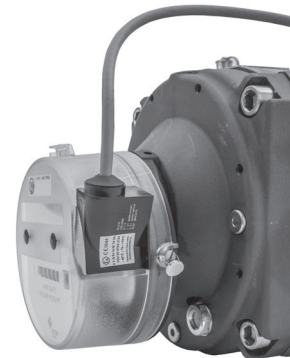

Figure 16. IN-S10 pulsar installed

Technical Specifications

| Description | Min. | Typ. | Max. | Unit |
|---------------------------------|-----------------|------|--------|------|
| Voltage (U _i) | | | ≤ 24 | V |
| Current (I _i) | | | ≤ 25 | mA |
| Power (P _i) | | | ≤ 0,25 | W |
| Static Contact Resistance | | | 200 | mΩ |
| Insulation Resistance | 10 ⁹ | | | Ω |
| Breakdown Voltage | 100 | | 100 | VDC |
| Switching Time Including Bounce | | 0.5 | | ms |
| Release Time | | 0.1 | | ms |

Temperature range: -40°C ... +70°C

IP-Class: IP67

Explosion protection: II 2 G Ex ia IIC T4 Gb

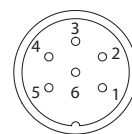
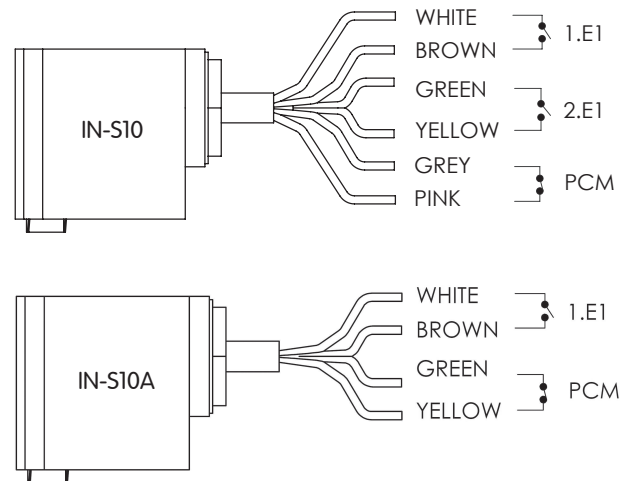

Pulsar Pin-Out Connections

| Connector | 1.E1 Pulse Out 1 | 2.E1 Pulse Out 2 | PCM Tamper Circuit |
|-----------|------------------------|------------------------|--------------------------|
| IN-S11 | 1 + 2 | 5 + 6 | 3 + 4 |
| IN-S12 | 1 + 2 (Back) | 1 + 2 (Front) | 3 + 4 (Front) |

Figure 17. Pulsar connections

13. Thermowell

All RABO meters come equipped with two (2) 1/4" NPT auxiliary ports on the meter body [Figure 18], which can be used for sensing pressure and temperature of the flowing gas. A thermowell is required when using a temperature sensing device. Thermowells are available as accessories to the meter.

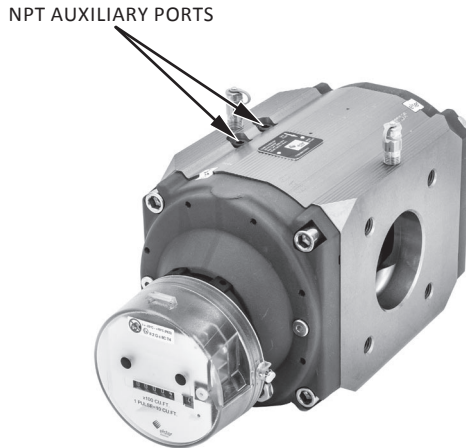

Figure 18. Auxiliary ports

a) Installing a Thermowell

1. If meter is not installed in the gas piping, go to Step 5.
2. Slowly open bypass valve.
3. Slowly close the meter's outlet valve, then the inlet valve.
4. Slowly, completely depressurize the meter piping.
5. Remove one of the plugs in the meter body by using a 1/4" hex key.
6. Apply Teflon tape or pipe dope to the male threads of the thermowell. Wipe excess pipe dope off the thermowell probe and leading threads to ensure no pipe dope enters the metering chamber.
7. Screw the thermowell into the meter and tighten to 18 ft-lbs.
8. Re-pressurize the meter as instructed in Start-up/Commissioning (see section 6).

14. Instrument Drive (ID)

RABO meters (3.5M/G65 and 5.5M/G100) can be retrofitted with an instrument drive, or instrument adaptor plate. The ID provides a mounting surface for instruments requiring mechanical rotational input. The drive rate of the RABO ID is 10 cubic feet per 1 revolution in a clockwise direction. When installing an instrument, orient the instrument face to the FRONT edge of the adaptor plate. The threads in the adaptor plate for instrument mounting are 5/16" - 18.

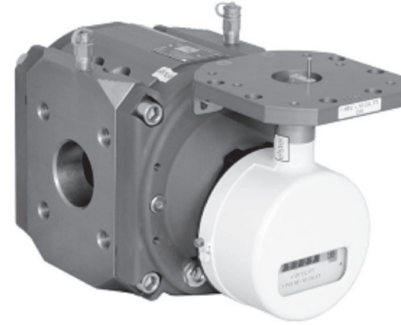

Figure 19. RABO with Instrument Drive

- a) Retrofit a CTR (CTR = Uncorrected Mechanical Totalizer) meter with an Instrument Drive (ID).
 - i) Remove index. See section 11. d) 1 to 11. d) 6
 - ii) Transfer the change gear from the CTR index to the ID gearing and index assembly [Figure 14 and 20].
 - (1) Pry the change gear's locking collar off with a knife blade or other similar object.
 - (2) Unscrew the change gear from the CTR index.
 - (3) Attach the change gear to the middle gear on the back side of the ID gearing and index assembly.
 - (4) Reinstall locking collar to retain the change gear.

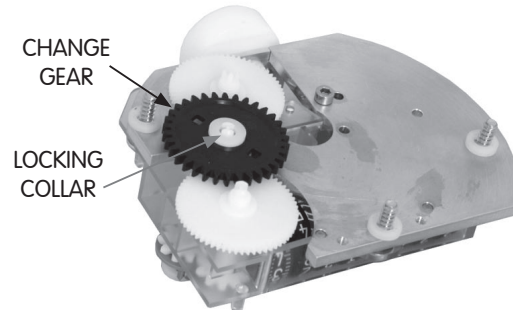

Figure 20. Change gear installation on ID gearing and index assembly

- iii) Remove the magnet holder assembly from the meter [Figure 21].

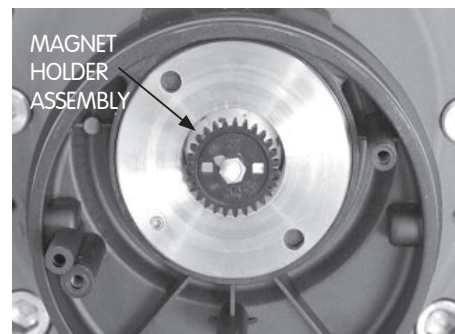

Figure 21. Magnet holder

- iv) Unscrew the lock nut from the magnet holder (THREADS ARE LEFT HAND) [Figure 17].

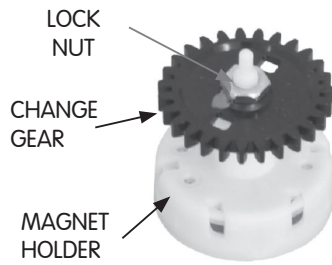

Figure 22. Magnet holder, change gear, and lock nut

- v) Unscrew the change gear from the magnet holder (THREADS ARE LEFT HAND) [Figure 22].
- vi) Assemble the change gear to the ID magnet holder (THREADS ARE LEFT HAND).
 - (1) For 3.5M meters
 - (a) Apply Loctite® 770 primer to the threads and mating surfaces of the change gear and the magnet holder [Figure 23]. Allow to dry for 30 seconds.

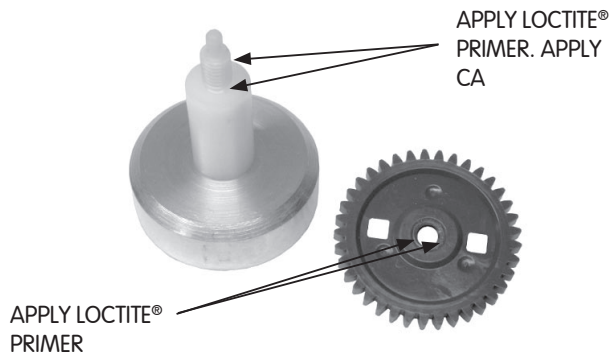

Figure 23. Magnet holder and change gear adhesive application for 3.5M meter.

- (b) Apply Loctite® 406, Loctite® 495, or equivalent Cyanoacrylate adhesive to the threads and mating surface of the magnet holder [Figure 23]. Do not get the adhesive on the small tip of the magnet holder.
- (c) Quickly screw the change gear to the magnet holder (THREADS ARE LEFT HAND) and tighten until gear is snugly seated against magnet holder. Let dry completely
- (d) Do not reinstall the locknut for a 3.5M meter.
- (2) For 5.5M meters
 - (a) Screw the change gear to the magnet holder (THREADS ARE LEFT HAND) and tighten until gear is snugly seated against magnet holder.
 - (b) Reinstall the lock nut (THREADS ARE LEFT HAND) removed in a previous step. Tighten until snug.
- vii) Install the ID magnet holder onto the end of the meter.
- viii) Install the ID gearing and index assembly on meter.
 - (1) Orient the ID gearing and index assembly so the mounting screws line up with the posts in the index base plate.
 - (2) Ensure the shaft on the magnet holder aligns with the support hole on the index frame [Figure 24].

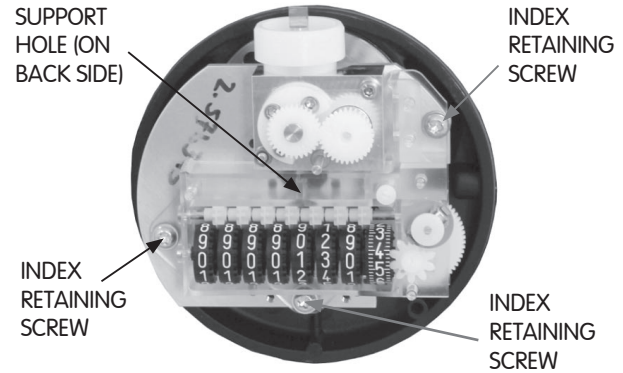

Figure 24. ID retaining screws

- (3) Tighten the three screws until snug. Do not overtighten.
 - (a) Each screw should have a 2mm thick retaining washer to space the ID gearing and index assembly away from the base plate [Figure 25]. The spacers are installed at the factory. Verify they have not fallen off.

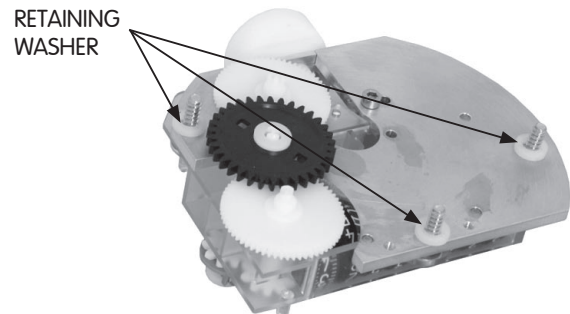

Figure 25. Retaining washers

- ix) Check for binds
 - (1) Using compressed air blown into the meter inlet port, confirm the index and ID output shaft rotate freely.
- x) Snap the ID index masking plate onto three posts of the index.
- xi) Install the ID index cover.
 - (1) Lightly lubricate the blue or purple o-ring on the index base plate with silicone o-ring grease.
 - (a) Do not use petroleum based lubricants on this o-ring.
 - (2) Place the ID index cover onto the index base plate while aligning the holes on the side of the index cover with the holes in the index base plate.
 - (3) Install the brass index cover mounting screws which were removed in a previous step. Tighten the screws just until the screw head contacts the cover, then back the screw out until the seal wire holes align.
- xii) Attach the support bracket to the accessory mount holes in the meter case cover [Figure 19, 26].
 - (1) The ID can be attached to a meter installed for horizontal or vertical flow. Use the appropriate accessory mount holes.

NOTE: Regardless the meter orientation installation, the ID adaptor plate must be mounted horizontally during operation so that the ID mounted accessory is in a vertical orientation.

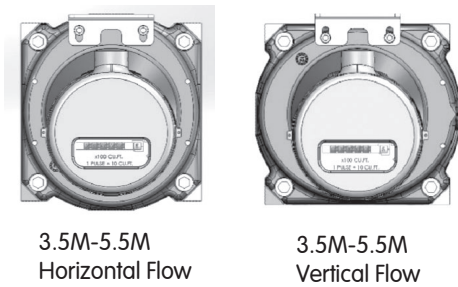

Figure 26. Support bracket attachment

- (2) Using a 5mm Allen wrench, loosely install two M6 socket head cap screws through the support bracket into the meter case cover [Figure 26]. The screws will be tightened after alignment of all parts.
- xiii) Install the adaptor plate assembly
 - (1) Lubricate the adaptor plate assembly o-ring with silicone o-ring grease, light machine oil or petroleum jelly.
 - (2) Carefully align the slot of the output shaft to the flat of the ID index output [Figure 27].

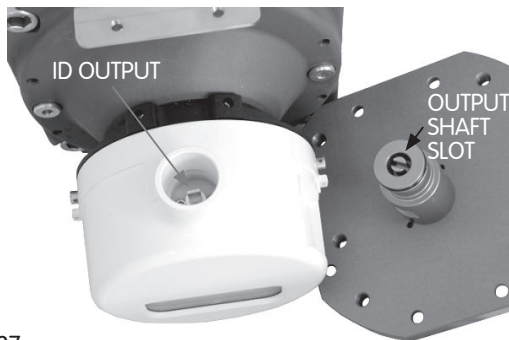

Figure 27.

- (3) Fully insert the adaptor plate assembly post into the index cover output hole.
- (4) Orient the adaptor plate to the desired direction (4 positions are possible: Facing away from the meter, facing the meter, facing the meter inlet, or facing the meter outlet).
- xiv) Using a 5mm Allen wrench, install two M6 socket head cap screws through the adaptor plate into the support bracket assembled in a previous step [Figure 28]. Tighten to 45-50 in-lbs.

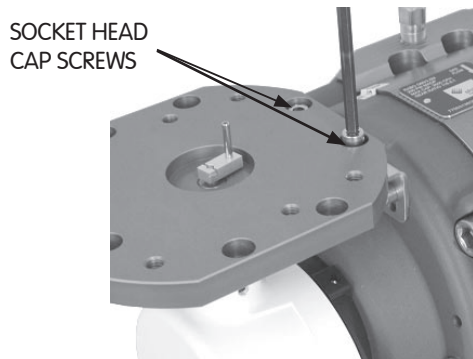

Figure 28.

- xv) Using a 3mm Allen wrench, install two set screws through the index cover neck to secure the adaptor plate assembly [Figure 29]. Tighten snugly.

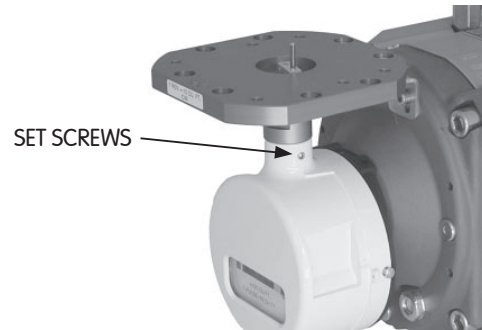

Figure 29. Set screw installation

- xvi) Tighten the two M6 socket head cap screws installed earlier (to affix the support bracket to the meter case cover) to 45-50 in-lbs.
- xvii) Install security seals as required.
 - (1) Security wires are included to secure the index cover mounting screws and the support bracket lower mounting screws.
 - (a) To install, feed the security wire through the holes in the drilled head screws, thread the free end of the wire through the hole in the center of the seal, pull tight, and snap the seal together.
 - (2) Red Security seals (plugs) are included to seal the support bracket upper mounting screws.
 - (a) To install, press the seals in the adaptor plate holes over the screws until they are fully seated.

15. Auxiliary Equipment Mounting

All RABO meters are equipped with threaded holes for mounting compact, lightweight auxiliary equipment [Figures 30 and 31]. All holes are M6 x 1 by 10mm deep. Heavier equipment should be pipe or wall mounted adjacent to the meter. Elster provides customized brackets for commonly used equipment [Figure 32]. Please contact your local Elster representative for details.

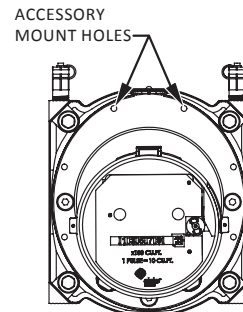

Figure 30. Horizontal installation

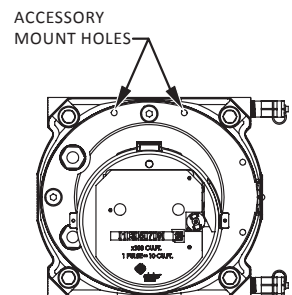

Figure 31. Vertical installation

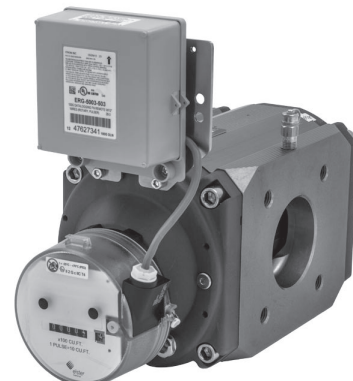

Figure 32. Auxiliary equipment mounted

16. Troubleshooting

| Problem | Probable Cause | Suggested Action |
|----------------------------|---|---|
| Excessive vibration | Build-up of foreign material on impellers | Clean by flushing, or replace worn parts |
| | Misalignment | Level meter in piping |
| | Worn bearings | Replace bearings |
| | Worn timing gears | Replace timing gears |
| | Impellers contacting body | Rotate manually to verify impellers spin freely |
| High differential pressure | Heavyweight or too much oil | Check oil level and condition |
| | Dirt deposits on impellers | Remove dirt by flushing |
| | Impellers out of time | Retime impellers |
| | Impellers contacting body | Rotate manually to verify impellers spin freely |
| Low registration | Upstream or bypass leak | Check all valves for leakage |
| Non-registration | Broken or binding index odometer | Replace odometer |
| | Obstruction in meter | Remove meter, remove obstructions, flush meter |

About Elster Gas

Elster provides best-in-class measurement and regulation products, systems and solutions for the safe control and delivery of natural gas across the globe.

Trusted Brands

- Elster American Meter Company, LLC
- Elster Canadian Meter Company, LLC
- Elster Perfection Corporation
- Elster Gas Depot
- Elster Instromet
- Elster Meter Services



ISO 9001
QMI-SAI Global

Elster American Meter Company, LLC
2221 Industrial Road
Nebraska City, NE 68410
USA

T +1 402 873 8200
F +1 402 873 7616

www.elster.com/gas
Elster is now part of Honeywell.

© 2017 by Elster. All rights reserved. Information contained herein is subject to change without notice. Contact your Elster representative for the most current product information.

Elster and Elster Logo are trademarks of Elster American Meter Company LLC.

73023895a/03.2017/TKGG