

VALUPAK®

Packaged gas burners



- High turndown.
- Available in 6 sizes.
- Capacities: 2 kW -1124 kW (HHV).
- Stable and clean combustion.
- Suitable for UV scanner and flame rod.
- Natural gas and LPG.
- Low gas pressure requirements.
- Ease of installation and operation with low maintenance requirements.
- All metal construction.
- Multi voltage and frequency blower motors.

Available VALUPAK® sizes

Capacity and selection data in kW, 50 Hz operation									
Gross heating value = 10.9 kWh/m ³ (st), d = 0.6									
All figures are for balanced - 0 mbar - duct pressure [1]									
VALUPAK® size	60 [2]			150 [2]	300 [2]	600	800	1000	
Standard blower type	UHC102	UHC122	UMI300						
Maximum heat release [3] kW(HHV)	40	60	80	185	325	645	880	1124	
Minimum heat release kW(HHV)	2	2	3	4	9	18	18	18	
Turndown	20:1	30:1	27:1	46:1	36:1	36:1	49:1	62:1	
Gas Q max. m ³ (st)/h	3.7	5.5	7.3	17	30	59	81	103	
Gas Q min. m ³ (st)/h	0.18	0.18	0.28	0.37	0.80	1.65	1.65	1.65	
Max. combustion air volume m ³ (st)/h	48	64	98	180	311	780	1170	1170	
Gas pressure at test connection at maximum heat release mbar	5.4	9	18	2.5	1	2.2	1.7	3.3	
Blower motor 3x220-420x50 Hz kW	0.09			0.09	0.18	1.1	0.55	1.1	
Weight kg	n/a			12.5	16.5	40	47	50	
Flame length [4] mm	up to 400 (after sleeve)			500	1000	1100	1600	1800	

[1] Air pressure switches should be selected to have a setpoint ranging from (2-10) mbar-, with exception of the VALUPAK® 60 burner with a capacity of 40 kW or 60 kW: setpoint ranging from (0.4 - 3) mbar

[2] Single phase blower motor available.

[3] Use of the standard round air inlet filter will cause a ± 15 % capacity reduction.

Use of the standard VALUPAK® burner at 60 Hz will result in a higher max. capacity to which the gas pressures need to be adapted.

[4] When firing in open air. Firing in a cross flow shortens flame.

Protection : IP54

- 1) Rp 1/2 gas inlet
- 2) Rp 3/4 gas inlet
- 3) Rp 1 gas inlet
- 4) Rp 1 1/4 gas inlet
- 5) Rp 1 1/2 gas inlet (Rp 1 1/4 for LPG)
- 6) Rp 1 1/2 gas inlet

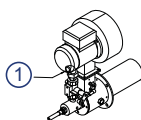

VALUPAK® 60

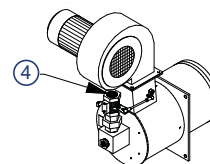

VALUPAK® 600

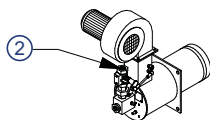

VALUPAK® 150

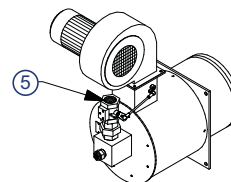

VALUPAK® 800

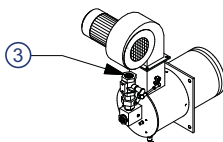

VALUPAK® 300

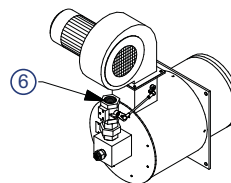

VALUPAK® 1000

Dimensions and weights

- 1) Gas inlet Rp1/2" with UHC122 & UM300 blower
- 2) Sight glass (alternative SI position)
- 3) Alternative SI position
- 4) Min.150 mm free space required for spark ignitor removal
- 5) Gas inlet Rp 1/2" with UHC102 blower
- 6) Alternative gas inlet position with UHC102 blower

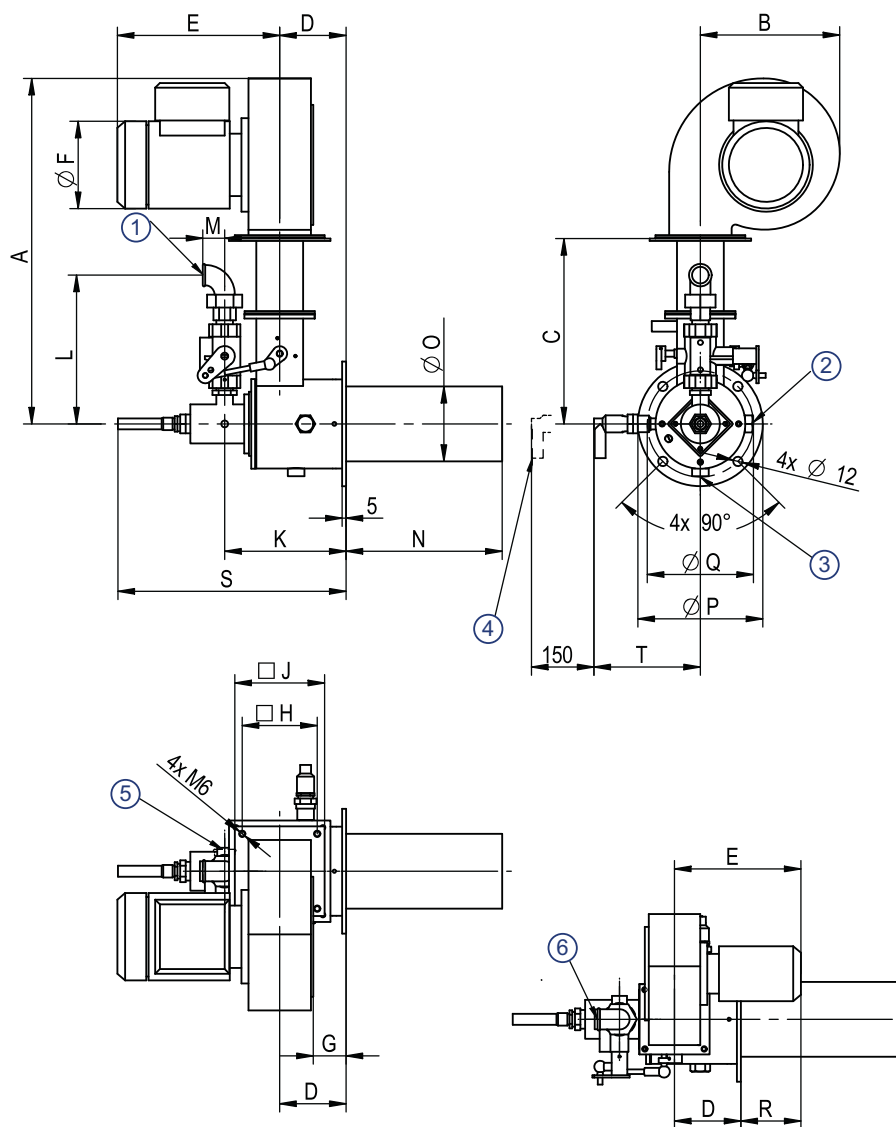

VAL 60	Dimensions in mm unless stated otherwise																	
Blower	A	B	C	D	E	F	G	H	J	K	L	M	N	O	P	Q	S	T
UHC102	302	135	140	85	162	71	40	76	90	155.5	191	28	200	96	160	136	297	136
UHC122	443	179	238		208	112	42	96	130									
UMI300	539	248	238		257	120	40.5	112	130									

Dimensions and weights

- 1) Round air filter (optional)
 - 2) Gas inlet (Y)
 - 3) Air press. switch connection
 - 4) Name plate
 - 5) Burner mounting holes 4x $\phi 13$
 - 6) Gas pressure test connection
 - 7) Air pressure test connection
 - 8) Observation port
 - 9) Rp1/2 flame detector connection
 - 10) Spark ignitor [1]
 - 11) Combustion air inlet
 - 12) Gas inlet (Z)
 - 13) Rp1/2 flame detector connection
 - 14) For size 150 & 300 = 4 x M6
for size 600 & larger = 4 x M8
 - 15) Discharge sleeve
- [1] spark ignitor 90° rotated (counter-clockwise) when looking into flame direction) on VALUPAK® 300 burner

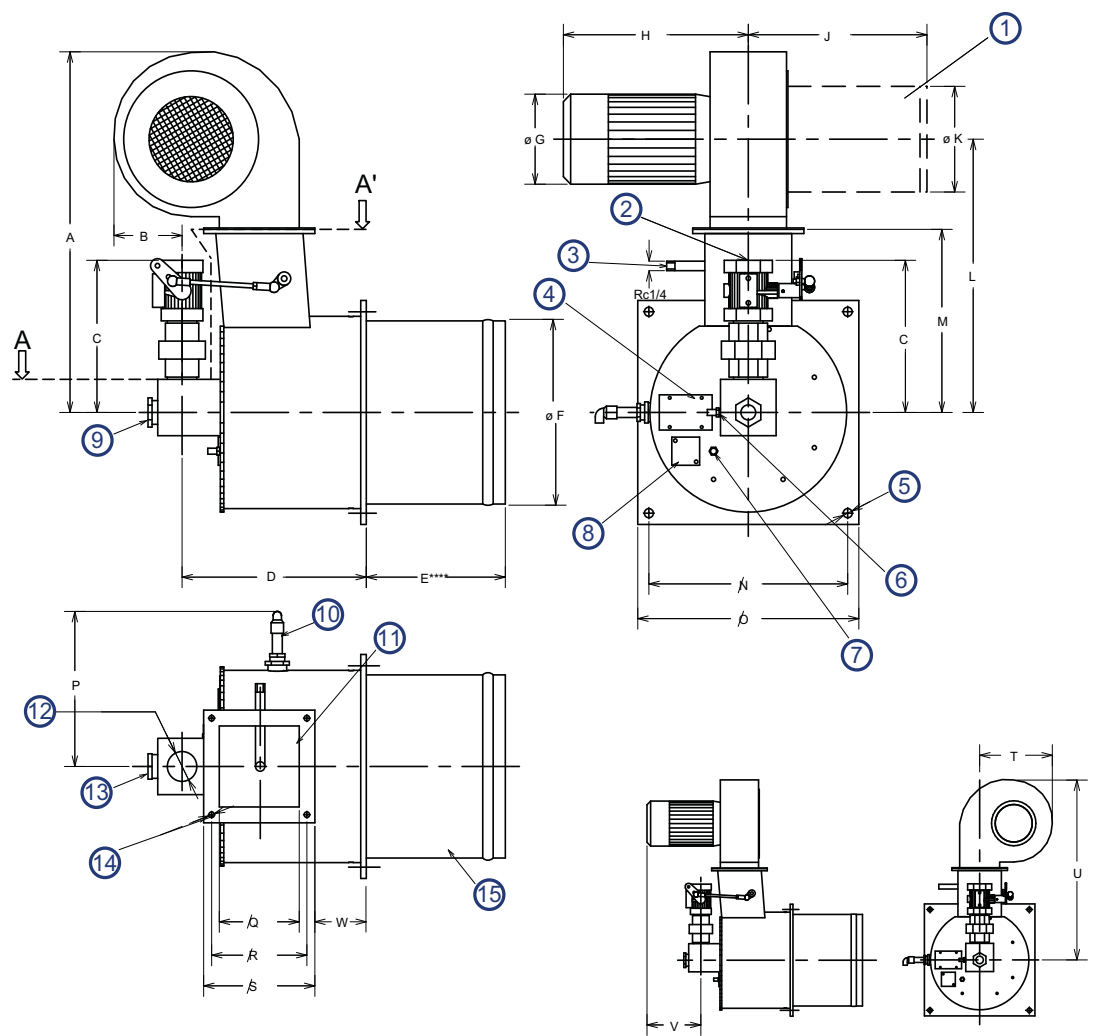

VALUPAK®		Dimensions in mm unless stated otherwise																						
Burner size	A	B	C	D	E [2]	F ϕ	G ϕ	H	J	K ϕ	L	M	N	O	P	Q	R	S	T	U	V	W	Y Rp	Z Rp
150	435	86	184	238	200	160	110	208	215	120	323	230	184	214	177	74	96	115	178	435	116	89	3/4	3/4
300	455	84	198	237	200	213	120	226	230	130	344	235	226	264	190	94	112	130	186	455	126	70	1	1
600	547	137	216	273	200	263	144	293	282	170	401	260	286	318	225	115	147	170	248	547	182	77	1-1/4	1-1/4
800 [1]	562	112	237 [1]	372	200	314	144	293	282	170	446	305	340	374	208	115	147	170	248	592	157	150	1-1/2	1-1/2 [1]
1000	592	112	237	372	200	314	144	293	282	170	446	305	340	374	208	115	147	170	248	592	157	150	1-1/2	1-1/2

[1] For LPG C=241 and Z=Rp 1.1/4
[2] 300 mm optional available

Applications

Specifically designed for applications where burners are used under balanced pressure conditions such as in textile machines, printing machines and many other types of dryers.

Options

- round air filter
- single phase motor for sizes 60, 150 and 300
- long discharge sleeve 300 mm
- control motor
- flame rod or UV scanner

Application example MAXON VALUPAK® 600 burner (gas)

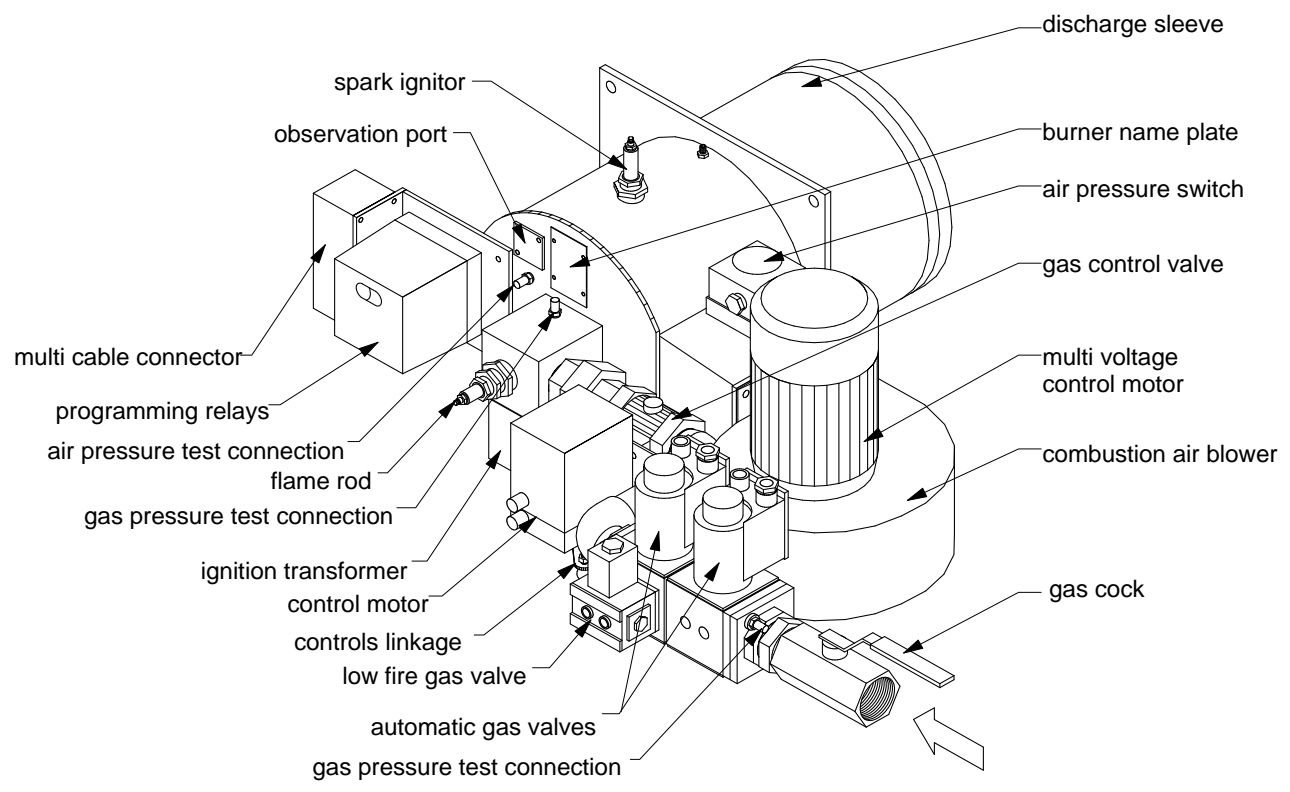

Read VALUPAK® instructions for complete information on VALUPAK® burners