

BURNERS HI-VELOCITY SINGLE TUNNEL DUAL FUEL

MODEL: 3640

Revision: 0

**BULLETIN
3640**

DESCRIPTION

The Hot Shot Dual Fuel (HSDF) series is a nozzle-mixing hi-velocity burner which will burn most gaseous fuels as well as light distillate oils. With either fuel being used the products of combustion are hi-velocity gases which provide fast penetration and improved temperature uniformity to the work in a furnace. As a result, greater efficiency is obtained and greater fuel savings realized. Being able to switch from one fuel to another without interruption gives the user great versatility in areas where gaseous fuels may be curtailed. Will operate on ratio and with excess air or gas for additional versatility.

(For Gas Only Hi-Velocity Burners, see Bulletin 3505.)

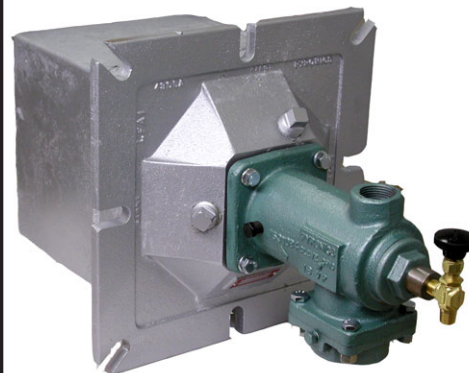

FEATURES

Hi-Velocity:	300 ft./sec. (oil) 250ft./sec (gas)
Refractory Block:	3000°F (3300°F refractory available)
Block Casings:	Steel or alloy available for fiber lined furnaces.
5 Sizes:	1-1/2" to 6" NPT Air Connections
Ratings:	350,000 to 5,600,000 BTU/hr. (oil) 320,000 to 5,150,000 BTU/hr. (gas)
Turndown:	8 to 1 (oil); 10 to 1 (gas)
Excess Air:	300% (without pilot)
Excess Fuel:	(Gas Only) 40% (without pilot)
Burner Ports:	Gas pilot, flame monitoring, and sight (sight glass not included)
Preheated Air:	Up to 750°F as Std. (1000°F unit available, consult factory)

APPLICATIONS

- Periodic Kilns - Shuttle Kilns - Tunnel Kilns
- Large Carbottom Furnaces - Heat Treating - Stress Relieving
- Ladle Heating - Impingement Heating - Reverberatory Furnaces

CAUTION: Operation of combustion equipment can be hazardous resulting in bodily injury or equipment damage. Each burner should be supervised by a combustion safeguard and only qualified personnel should install, make system adjustments and perform any required service.



pyronics
A Selas Heat Technology Brand

11012 Aurora Hudson Road Toll Free: 800-883-9218
Streetsboro, OH 44241 Main: 216-662-8800
Email: sales@selas.com Fax: 216-663-8954

NOTICE: Pyronics practices a policy of continuous improvement in the design of its products. It reserves the right to change the specifications at any time without prior notice.

BURNERS HI-VELOCITY SINGLE TUNNEL DUAL FUEL

BULLETIN 3640
PAGE NO. 2

DIMENSIONS

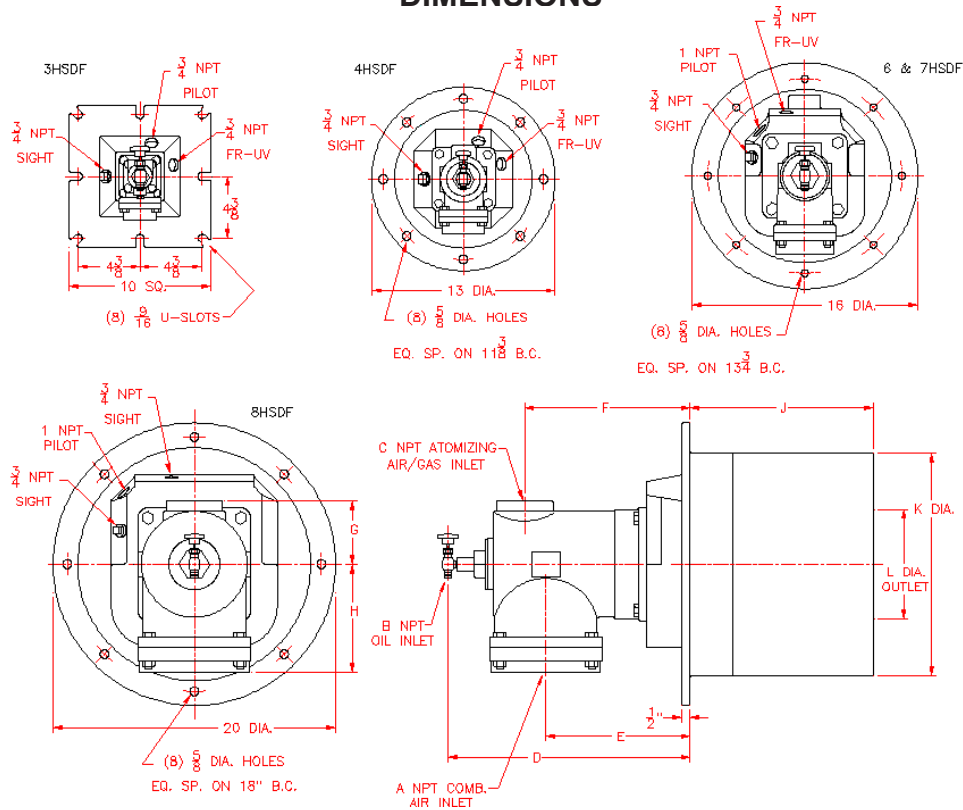

Model No.	A NPT	B NPT	C NPT	D	E	F	G	H	J	K DIA	L DIA
3HSDF-R	1-1/2	1/4	3/4	12-1/2	4-3/4	8	1-1/8	3-1/8	9	7	2
4HSDF-R	2	1/8	1	11-1/8	6-1/4	7-1/8	2-3/8	3-7/8	10	8	2-3/4
6HSDF-R	3	1/4	1-1/2	15-1/8	9-3/8	10-1/4	2-3/8	5-1/2	12	11-3/4	3-3/4
7HSDF-R	4	1/4	2	15	9-1/4	10-1/8	3-1/8	5-5/8	12	11-3/4	5-1/2
8HSDF-R	6	1/4	3	17-1/8	10-1/4	11-3/4	4-1/2	7-5/8	13	15-3/4	7-3/4

Note: All dimensions are in inches ± 1/8

Model No.	Natural Gas 0.64 Sp. Gr. 1000 BTU/hr @ 20 oz.	No. 2 Fuel Oil 1000 BTU/hr	GPH Oil	Oil Atomizing Air SCFH @ 20 oz.	Oil Combustion Air SCFH @ 20 oz.	Flame Length on Ratio	Pilot
3HSDF	320	350	2.5	350	3,500	14"	P62 PBST
4HSDF	655	700	5.0	700	7,000	22"	P62 PBST
6HSDF	1,290	1,400	10.0	1,400	14,000	28"	P86 PBST
7HSDF	2,425	2,800	20.0	2,800	28,000	40"	P86 PBST
8HSDF	5,150	5,600	40.0	5,600	56,000	45"	P86 PBST

* Assuming 140,000 BTU/hr per gallon of #2 Fuel Oil.

Total Air Required for Oil = Combustion Air + Atomizing Air

ORDERING INFORMATION

1. Add to Model No. for Block Holder and Refractory required.
 - 1 With Std. Refractory less Jacket 3000°F.
 - 2 With Hi-Temp. Refractory Less Jacket 3300°F.
 - C With Alloy Jacket & Std. Refractory 3000°F.
 - D With Alloy Jacket & Hi-Temp. Refractory 3300°F.
 - E With Short Alloy Jacket & Std. Refractory 3000°F.
 - F With Short Alloy Jacket & Hi-Temp. Refractory 3300°F.
2. Specify Model No. & Quantity.
3. Type of Fuel and Pressure available.
4. Specify Pilot Model No. (If required).
5. Specify Sight Glass Model No. (if required).
6. Shipping Instructions.