

# APX™

## Nozzle-mix line burner



- Nozzle-mixing line burner for use with low pressure natural gas, propane and butane
- Eliminates leakage with its single-piece, aluminum extrusion body design
- Cooler oven walls due to deeper penetration inside the oven (wall-mounted applications)
- Independent of variable process air-flows (in-duct applications)
- Corrosion resistant main gas/air body and durable stainless steel mixing plates
- Up to 40:1 turndown
- Up to 400 kW per foot
- Packaged units up to 15 ft in length (1 ft = 305 mm)

W W W . M A X O N C O R P . C O M

COMBUSTION SYSTEMS FOR INDUSTRY

Maxon reserves the right to alter specifications and data without prior notice.  
© 2016 Copyright Maxon Corporation. All rights reserved.

**Honeywell**

**MAXON**

## Product description

MAXON APX™ burners are packaged nozzle-mix line burners, especially designed for fresh or low temperature recirculating air heating applications.

The APX™ burner is a value engineered design utilizing a single aluminum extrusion for both its main air and fuel manifolds. Its single-piece, seamless body design eliminates burner leakage and maximizes burner performance.

- 1) Gas/air body
- 2) Air box
- 3) Gas pipe
- 4) Mixing plate
- 5) Side plate

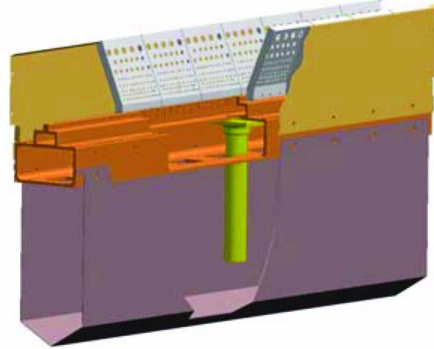
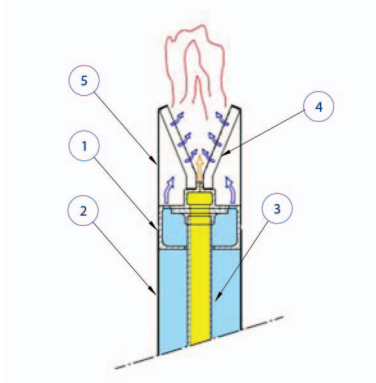

The particular drilling pattern of the air/gas mixing body provides increased turbulence as well as uniform air distribution across the entire burner length. This results in better gas/air mixing, shorter flames, more resistance to cross-flows and much lower emissions.

The design of the APX™ burner allows for high turndown without premixing fuel and air at low firing rates. Low emissions are maintained through precise aeration of the flame along its length. This progressive aeration of the flame is achieved with the advanced mixing plate design of MAXON NP AIRFLO® Line burner.

The APX™ burner is built in 2 main versions, both available in lengths of 0,5 ft up to 15 ft (1ft = 305 mm) :

- A **wall-mounted APX™ burner** to be externally mounted on oven or dryer walls.  
With a flame that exits the mixing chamber more than 150 mm downstream from the burner mounting flange, it is possible to penetrate oven panels up to 150 mm thickness without risking damage to oven structure from flame impingement.
- An **in-duct APX™ burner** to heat-up low temperature process air flows.

For both versions, you can choose between:

- the **standard APX™ burner** with 1 or more gas and air inlet connections on the back of the burner, depending on the burner length.
- the **packaged APX™ burner** equipped with one or more low horse-power paddle wheel fans, which resist possible particle build-up and provide higher air pressures.

Additionally, the APX™ in-duct burner is also available as a "slide-in-unit", with a mounting plug or plate which can be easily flanged onto the duct.

A complete product overview is shown in "Specifications of APX™ burners" - page 3.

Special grid versions or burner lengths extending beyond 15 ft are also available. Contact MAXON for more information.

## Available APX™ sizes

Whatever APX™ version has been selected, the typical burner data per foot of burner are equal and shown in the below table. Note that these are typical data, which may slightly vary depending on the application and/or process design data.

<b>Typical burner data</b>			
<b>Fuel: natural gas with 10.9 kWh/Nm<sup>3</sup> HHV - sg = 0,6 [1]</b>			
<b>Combustion air: 15° C - 21 % O<sub>2</sub> - 50 % Humidity - sg = 1,0 [1]</b>			
Stated pressures are indicative. Actual pressures are a function of air humidity, altitude, type of fuel and gas quality.			
		Fresh process air firing 21 % O <sub>2</sub> - 15° C	Recirculating air firing (low O <sub>2</sub> to almost inert higher upstream temperatures)
Max. capacity per foot	[2] kW (HHV)	400	300
Max. flame length (fresh process air - 21 % O <sub>2</sub> - 15° C)	[3] m	1 to 1,5	2 to 3
Turndown		40:1	30:1
Comb. air pressure at max. capacity	[4] mbar	21	16
Corresponding excess air factor	[5] n	1,1	1,3
Natural gas pressure at max, capacity (SP drillings)	[6] mbar	78	43
Natural gas pressure at max, capacity (LP drillings)	[7] mbar	41	23

[1] sg (specific gravity) = relative density to air (density air = 1,293 kg/Nm<sup>3</sup>)

[2] Advised maximum capacities per ft. Overfiring is possible (up to 20%) if special considerations are taken. Overfiring will give longer flames. Contact MAXON for more information.

[3] Typical flame lengths for shown excess air and capacity. Process oxygen levels, process velocities and air distribution may influence flame length. Contact MAXON for detailed information.

[4] Differential air pressure between burner test connection and combustion chamber for burner commissioning.

[5] Advised excess air factor for given capacity and optimal burner performance. Higher excess air factor will reduce flame length. Contact MAXON for more information.

[6] Differential natural gas pressure between burner gas test connection and combustion chamber (SP = standard pressure drillings).

[7] Differential natural gas pressure between burner gas test connection and combustion chamber (LP = low pressure drillings).

## Applications

MAXON APX™ burners are installed in a wide variety of applications.

The wall-mounted APX™ burner is typically used on low temperature ovens with air recirculation (food, canning, construction materials, etc.).

The in-duct APX™ burner is perfectly suitable for direct air heating. The clean hot air generated by the burner meets most of the local requirements for make-up air systems, independent from possible variations of the process air flow (make-up, paint shops).

Besides make-up air heating and low temperature ovens, the APX™ burner is widely used in all kinds of drying applications with fresh process air, or in recirculating low oxygen/ high humidity atmospheres (paper, food, gypsum).

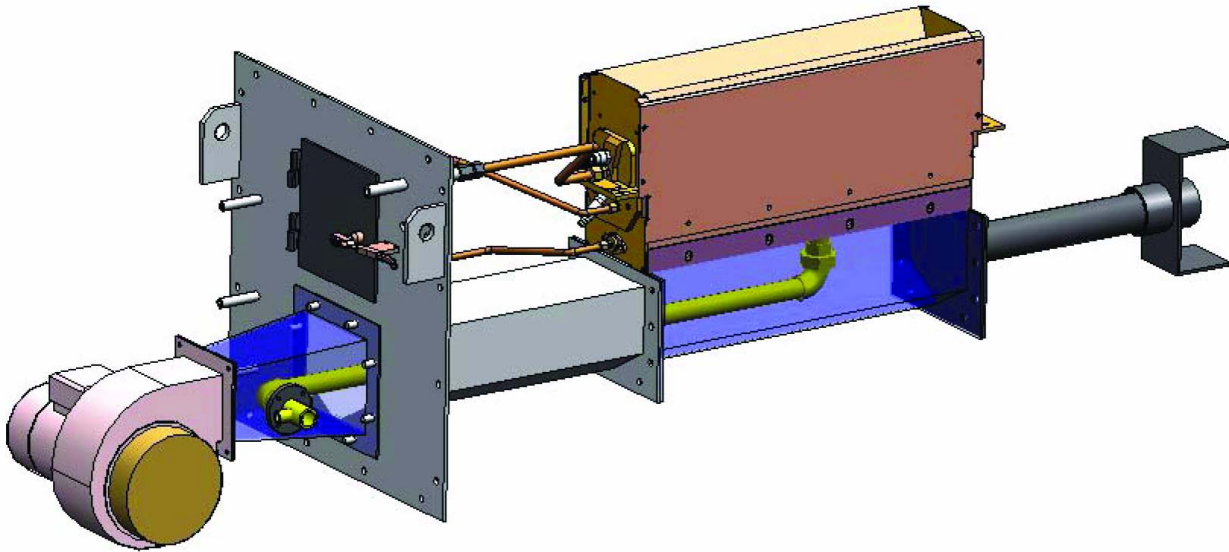

**2 ft APX™ burner of 300 kW for low temperature air heating in a spray booth. Slide-in-unit for easy in-duct installation. Including combustion air blower, main and pilot gas connection, gas and air test connections and electrical feed through for spark ignitor and flame rod.**

**Dimensions and weights**

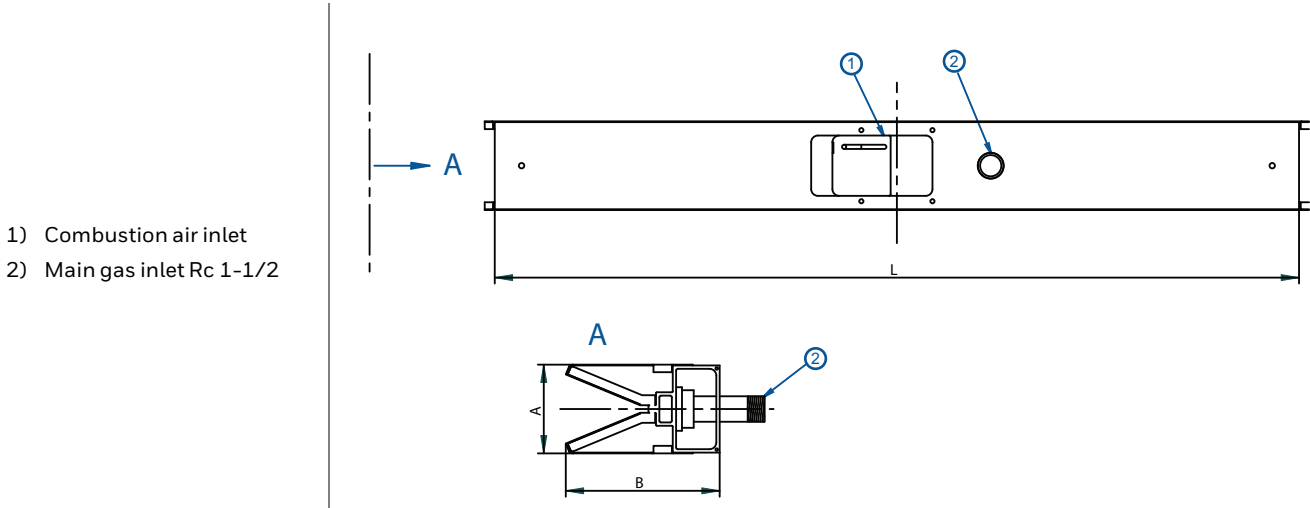

- 1) Combustion air inlet
- 2) Main gas inlet Rc 1-1/2

Dimensions in mm unless stated otherwise															
burner size (ft)	1	2	3	4	5	6	7	8	9	10	11	12	13	14	15
L	305	610	914	1219	1524	1829	2134	2438	2743	3048	3353	3658	3962	4267	4572
Weight (kg)	6	12	19	25	31	37	43	49	56	62	68	74	80	87	93
A	168														
B	292														



**Number and position of gas and air inlets depends on burner size. Refer to “Specifications of APX™ burners” for additional details.**

## Typical emissions (burners only)

Thanks to the advanced mixing technology of the single-piece gas/air body, MAXON APX™ burners combine excellent flexibility and turndown with very sharp emission levels on both CO and NO<sub>x</sub>. Contact MAXON for more information.

*Read "Specifications of APX™ burners" for correct and complete information on APX™ burners.*

## Specifications of APX™ burners

### APX™ Burner - STRAIGHT - packaged blower [1]

Typical burner data [2]									
Fuel: natural gas with 10,9 kWh/Nm <sup>3</sup> humidity - sg = 0,6 [3]									
Combustion air: 15 °C - 21% O <sub>2</sub> - 50% humidity - sg = 1,0									
Stated pressures are indicative. Actual pressures are a function of air humidity, altitude, type of fuel and gas quality.									
Burner Size [4]	Differential gas pressure Standard drilling [5] mbar	Differential gas pressure low pressure drilling [5] mbar	Maximum capacity [6] kW HHV	Differential air pressure [7] mbar	Nominal air flow [8] m <sup>3</sup> /h	Min. Capacity kW HHV	Flame length [9] mm	Blower Horsepower hp	Number of blowers
0.5	43	14	117	3,7	136	4	750-1000	1/12	1
1	43	23	300	10	300	7	750-1000	1/2 [10]	1
1.5	43	23	450	10	450	11	750-1000	1/2 [10]	1
2	43	23	600	10	600	15	750-1000	1	1
2.5	43	23	750	10	750	18	750-1000	1	1
3	43	23	900	10	900	22	750-1000	1	1
3.5	43	23	1050	10	1050	26	750-1000	1,5	1
4	43	23	1200	10	1200	29	750-1000	1,5	1
5	43	23	1500	10	1500	37	750-1000	3	1
6	43	23	1800	10	1800	44	750-1000	1	2
7	43	23	2100	10	2100	51	750-1000	1,5	2
8	43	23	2400	10	2400	59	750-1000	1,5	2
9	43	23	2700	10	2700	66	750-1000	3	2
10	43	23	3000	10	3000	73	750-1000	3	2
11	43	23	3300	10	3300	81	750-1000	3	2
12	43	23	3600	10	3600	88	750-1000	1.5	3
13	43	23	3900	10	3900	95	750-1000	3	3
14	43	23	4200	10	4200	103	750-1000	3	3
15	43	23	4500	10	4500	110	750-1000	3	3

[1] Not for EC-market - see "Available APX™ versions and options" page 12 and page 13.

[2] Burner data displayed assume blower(s) operating on 60 Hz electrical supply. Max. burner capacity will be reduced by 17 % if operated on 50 Hz. Fuel and air pressure should be reduced by 30 % while motor power will reduce 40 % with 50 Hz operation.

[3] sg (specific gravity) = relative density to air (density air = 1,293 kg/Nm<sup>3</sup>).

[4] Burner size corresponds with the straight burner length in ft.

[5] Pressure differential between burner test connection and combustion chamber for natural gas to be used for burner commissioning - LP burner (Low Pressure drillings). Actual pressure differential at burner gas inlet is 5 % higher.

[6] Fresh air firing. When firing in low oxygen environment, max. capacity should be downrated.

[7] Differential combustion air pressure between burner air test connection and combustion chamber for commissioning.

[8] When firing in balanced combustion chamber.

[9] Expected flame length in fresh air firing. Flame length may vary as a function of process air flow distribution, velocity, temperature, oxygen level etc. Contact MAXON for more information.

[10] 575 volt version in 3/4 HP.

APX™ burner - H - external blower conversion table to corresponding straight lengths of burner in feet

Burner size	Burner dimension (ft)	Corresponding straight length (ft)
APX 1 x 1 H	1 x 1	3
APX 1 x 1.5 H	1 x 1.5	3.5
APX 1 x 2 H	1 x 2	4
APX 1 x 2.5 H	1 x 2.5	4.5
APX 2 x 1 H	2 x 1	5
APX 2 x 1.5 H	2 x 1.5	5.5
APX 2 x 2 H	2 x 2	6
APX 2 x 2.5 H	2 x 2.5	6.5
APX 3 x 1 H	3 x 1	7
APX 3 x 1.5 H	3 x 1.5	7.5
APX 3 x 2 H	3 x 2	8
APX 3 x 2.5 H	3 x 2.5	8.5
APX 3 x 3.5 H	3 x 3.5	9.5

Example:

APX™ 2 x 2.5 H corresponds with 6.5 ft straight burner length.

Use table page 7 and page 8 for typical burner data per foot of burner.



APX™ burner firing on natural gas - modulated combustion air [1] - STRAIGHT and H - external blower

<b>Typical burner data</b> <b>Fuel: natural gas with 10,9 kWh/Nm³ HHV - sg = 0,6 [2]</b> <b>Combustion air: 15 °C - 21% O<sub>2</sub> - 50 % humidity - sg = 1,0 [2]</b> <b>Stated pressures are indicative. Actual pressures are a function of air humidity, altitude, type of fuel and gas quality.</b>									
	APX™ natural gas firing - Capacity per foot [10]	[3]	kW (HHV)	10	50	100	200	300	400
	Differential natural gas pressure SP burner	[4]	mbar	0,1	1,2	4,9	20	43	78
	Differential natural gas pressure LP burner	[5]	mbar	0,1	0,7	2,6	10,2	23	41
Fresh air firing	Differential combustion air pressure for fresh air firing	[6]	mbar	1,1	1,1	1,1	4,4	10	18
	Differential combustion air pressure at blower outlet for fresh air firing	[7]	mbar	1,7	1,7	1,7	6,5	15	27
	(Optimal) combustion air flow for fresh air firing	[8]	m <sup>3</sup> (st)/h/ft	100	100	100	200	300	400
	(Optimal) combustion air factor for fresh air firing	[8]	n	11	2,2	1,1	1,1	1,1	1,1
	Flame length (fresh air firing)	[9]	m	NA	0,3	0,5 - 0,8	0,8 - 1,1	1,1 - 1,4	1,4 - 1,7
Recirculation air with low O <sub>2</sub> and higher upstream temperature	Differential combustion air pressure for recirculating air firing (low O <sub>2</sub> . n>=1,3)	[6]	mbar	1,1	1,1	1,6	6,3	14	25
	Differential combustion air pressure at blower outlet for recirculating air firing (low O <sub>2</sub> . n>=1,3)	[7]	mbar	1,7	1,7	3	9	20	38
	(Optimal) combustion air flow for recirculating air firing (low O <sub>2</sub> . n>=1,3)	[8]	m <sup>3</sup> (st)/h/ft	100	100	120	240	350	NA
	(Optimal) combustion air factor for recirculating air firing (low O <sub>2</sub> . n>=1,3)	[8]	n	11	2,2	1,3	1,3	1,3	NA
	Flame length (recirculating air firing (low O <sub>2</sub> . n>=1,3)	[9]	m	NA	0,5 - 0,8	1,2 - 1,5	2 - 2,5	2,8 - 3,2	(3,5)

- [1] If an APX™ burner is used with constant combustion air, select the required combustion air pressure from above table for required maximum capacity per foot.
- [2] sg (specific gravity) = relative density to air (density air = 1,293 kg/Nm³).
- [3] 10 kW/ft is the minimum capacity for natural gas (1 control valve per burner, SP drillings see [4]).The maximum capacity is set at 400 kW/ft. Overfiring in fresh air heating application is possible (up to 20 %). For low oxygen recirculating applications, we advise to limit the max. capacity per foot to 300 kW, with n = 1,3
- [4] Pressure differential between burner test connection and combustion chamber for natural gas to be used for burner commissioning - SP burner (Standard Pressure drillings).  
Actual pressure differential at burner gas inlet is 5 % higher.
- [5] Pressure differential between burner test connection and combustion chamber for natural gas to be used for burner commissioning - LP burner (Low Pressure drillings).  
Actual pressure differential at burner gas inlet is 5 % higher.
- [6] Differential combustion air pressure between burner air test connection and combustion chamber for commissioning.
- [7] Typical differential combustion air pressure for 5 ft APX™ to be used for blower selection.
- [8] Advised combustion air flow and air factor "n" for best burner performance. For recirculating air heating with low oxygen, advised air factor is 20 % higher (n >= 1,1 for fresh air firing, n >= 1,3 for recirculating processes).
- [9] Typical flame length for shown air amount and capacity. Flame length may vary as a function of process air flow distribution, velocity, temperature, oxygen level etc. Contact MAXON for more information.
- [10] 1 foot = 305 mm

## APX burner firing on propane - modulated combustion air flow [1] - STRAIGHT and H - external blower

Typical burner data									
Fuels: propane with 26,83 kWh/Nm <sup>3</sup> HHV - sg = 1,57 [2] butane with 34,82 kWh/Nm <sup>3</sup> HHV - sg = 2,07 [2]									
Combustion air: 15 °C - 21% O <sub>2</sub> - 50 % humidity - sg = 1,0 [2]									
Stated pressures are indicative. Actual pressures are a function of air humidity, altitude, type of fuel and gas quality.									
	APX™ propane/butane firing - Capacity per ft [10]	[3]	kW (HHV)	20	50	100	200	300	400
	Differential propane gas pressure SP burner	[4]	mbar	0,1	0,5	1,9	7,5	17	30
	Differential butane gas pressure SP burner	[5]	mbar	0,1	0,4	1,4	5,8	13	23
Fresh air firing	Differential combustion air pressure for fresh air firing	[6]	mbar	10	10	10	10	10	18
	Differential combustion air pressure at blower outlet for fresh air firing	[7]	mbar	15	15	15	15	15	21
	(Optimal) combustion air flow for fresh air firing	[8]	m <sup>3</sup> <sub>(st)</sub> /h/ft	150	200	200	200	300	400
	(Optimal) combustion air factor for fresh air firing	[8]	n	8,9	4,4	2,2	1,1	1,1	1,1
	Flame length (fresh air firing)	[9]	m	NA	0,3	0,5-0,8	0,8-1,2	1,2-1,5	1,5-1,9
Recirculation air with low O <sub>2</sub> and higher upstream temperature	Differential combustion air pressure for recirculating air firing (low O <sub>2</sub> , n>=1,3)	[6]	mbar	10	10	10	10	15	25
	Differential combustion air pressure at blower outlet for recirculating air firing (low O <sub>2</sub> , n>=1,3)	[7]	mbar	15	15	15	15	21	38
	(Optimal) combustion air flow for recirculating air firing (low O <sub>2</sub> , n>=1,3)	[8]	m <sup>3</sup> <sub>(st)</sub> /h/ft	300	300	300	300	350	(NA)
	(Optimal) combustion air factor for recirculating air firing (low O <sub>2</sub> , n>=1,3)	[8]	n	33	6,6	3,3	1,6	1,3	(NA)
	Flame length (recirculating air firing (low O <sub>2</sub> , n>=1,3)	[9]	m	NA	0,5-0,8	1,2-1,5	2-2,5	2,8-3,2	(3,5)

- [1] If an APX™ is used with constant combustion air, select the required combustion air pressure from above table for required maximum capacity per foot.
- [2] sg (specific gravity) = relative density to air (density air = 1,293 kg/Nm<sup>3</sup>)
- [3] 20 kW/ft is the minimum capacity for propane/butane firing (1 control valve per burner, SP drillings see [4]). The maximum capacity is set at 400 kW/ft. Overfiring in fresh air heating application is possible (up to 20%). For low oxygen recirculating applications we advise to limit the max.capacity per foot to 300 kW, with n = 1.3
- [4] Pressure differential between burner test connection and combustion chamber for propane/butane to be used for burner commissioning - SP burner (Standard Pressure drillings).  
Actual pressure differential at burner gas inlet is approx. 5 % higher.
- [5] Pressure differential between burner test connection and combustion chamber for natural gas to be used for burner commissioning - LP burner (Low Pressure drillings).  
Actual pressure differential at burner gas inlet is 5 % higher.
- [6] Differential combustion air pressure between burner air test connection and combustion chamber for commissioning.
- [7] Typical differential combustion air pressure for 5 ft APX™ to be used for blower selection.
- [8] Advised combustion air flow and air factor "n" for best burner performance. For recirculating air heating with low oxygen, advised air factor is 20 % higher (n >= 1.1 for fresh air firing, n >= 1.3 for recirculating processes).
- [9] Typical flame length for shown air amount and capacity. Flame length may vary as a function of process air flow distribution, velocity, temperature, oxygen level etc. Contact MAXON for more information.
- [10] 1 foot = 305 mm

### Materials of construction

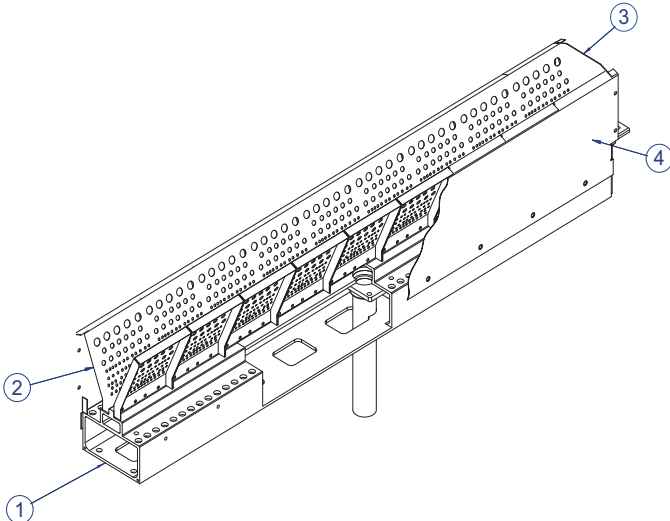

1)	Air/gas mixing body	Aluminum
2)	Mixing plates	AISI 430 (1.4016)
3)	Endplate	Cast iron or AISI 304 (1.4301)
4)	Sideplate	Galvanized or AISI 430 (1.4016)

## Selection criteria

### Application details

---

The MAXON APX™ nozzle-mix line burner has been especially designed for low temperature air heating applications, where standard raw gas line burners (MAXON "NP" AIRFLO®) are not suitable.

Thanks to its unique single-piece air/gas mixing body, APX™ strongly differentiate from the regular "box burner", with excellent flame stability and flexibility, also in high modulating and/or low oxygen process air flows.

Basically, APX™ is available in two main versions.

A wall-mounted APX™ to be externally mounted on the oven or dryer wall. Thanks to the flame that exits the mixing chamber more than 150 mm downstream from the burner mounting flange, it is possible to penetrate oven panels up to 150 mm thickness without risking damage to oven structure from flame impingement.

The in-duct APX™ is installed inside the dryer or make-up air unit to heat-up low temperature process air flows.

### Available APX™ versions and options

---

The two basic APX™ versions, wall-mounted and in-duct, are available in several variations. Below tables give an overview of the different options of each version.

Note that wall-mounted APX™ burners are always mounted on suction side of circulating fans, or in balanced ducts.

Whether slot or continuous flange mounted burner should be selected depends upon the desired amount of cooling/purge air around the burner.

The packaged blower option is not available on the EC-market. For EC-market, same execution can be achieved by selecting the external blower option, and mounting an appropriate European blower direct onto the air inlet connection of the burner.



To comply with local codes and directives, special provisions may be required to correctly safeguard the minimum combustion air pressure in case multiple blowers are mounted on the burner.

Wall-mounted APX™ "WM" [1]			
Slot-mounted "SM"		Continuous flange mounted "CF"	
Packaged blower "PB"	External blower "EB"	Packaged blower "PB"	External blower "EB"
0.5 ft to 5 ft Straight [2][3]	1 ft to 5 ft Straight [2]	0.5 ft to 5 ft Straight [2][3]	1 ft to 5 ft Straight [2]
5.5 ft to 15 ft Straight [2][3]	5.5 ft to 15 ft Straight [2]	5.5 ft to 15 ft Straight [2][3]	5.5 ft to 15 ft Straight [2]
NA	(1 x 1) to (1 x 2.5) ft H [2][4]	NA	(1 x 1) to (1 x 2.5) ft H [2][4]
NA	(2 x 1) to (2 x 2.5) ft H [2][4]	NA	(2 x 1) to (2 x 2.5) ft H [2][4]
NA	(3 x 1) to (3 x 3.5) ft H [2][4]	NA	(3 x 1) to (3 x 3.5) ft H [2][4]

- [1] All burners are available with constant or modulated combustion air flow.  
All burners are available with SP and LP drillings (standard pressure / low pressure - see tables page 7 and page 8).
- [2] Available in increments of 0,5 feet (0.5 / 1 / 1.5 / 2 ft,etc.).
- [3] Not available on EC-market.
- [4] H-style burners. Contact MAXON for other grid configurations.

Example: "APX™ SM-EB-SP-7.5 ft STRAIGHT"  
= wall-mounted APX™ of 7.5 ft straight, slot mounted for external blower, with standard pressure drillings.







In-duct APX™ "ID" [1]		
Packaged blower "PB"	External blower "EB"	Slide-in-unit "SU"
0.5 ft to 5 ft Straight [2][3]	0.5 ft to 5 ft Straight [2]	0.5 ft to 5 ft Straight [5]
5.5 ft to 15 ft Straight [2][3]	5.5 ft to 15 ft Straight [2]	5.5 ft to 15 ft Straight [5]
NA	(1 x 1) to (1 x 2,5) ft H [2][4]	NA
NA	(2 x 1) to (2 x 2,5) ft H [2][4]	NA
NA	(3 x 1) to (3 x 3,5) ft H [2][4]	NA

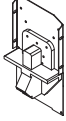
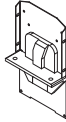
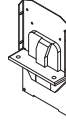

- [1] All burners are available with constant or modulated combustion air flow.  
All burners are available with SP and LP drillings (standard pressure / low pressure - see tables page 7 and page 8).
- [2] Available in increments of 0.5 feet (0.5 / 1 / 1.5 / 2 ft,etc.)
- [3] Not available on EC-market.
- [4] H-style burners. Contact MAXON for other grid configurations.
- [5] In-duct APX™ "Slide-in-units" with mounting plug or plate to be flanged onto the duct.

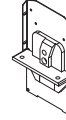
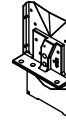
Example: "APX™ ID-SU-LP-14 ft STRAIGHT"  
= in-duct APX™ burner slide-in-unit of 14 ft with low pressure drillings.

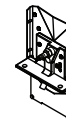
## Endplate set options

Different types of endplates are available for MAXON APX™ burners. Refer to the table below for selection of the most appropriate pilot endplates.

Overview of Endplate set options for MAXON APX™ burners				
Description	Designation [1]	Wall-mount	In-duct	3D-View
Raw gas pilot endplate set with air bypass (incl. SI, pilot gas connection, FR or provision for UV-scanner) [2]	FIG1-FR	yes	no	
	FIG1-UV	yes	no	
Endplate set with FR only	FIG2-FR	yes	yes	
Endplate set with sight glass only	FIG2-SG	yes	yes	
Plain endplate set	FIG2-PLN	yes	yes	
Endplate set for direct ignition (with SI only)	FIG3-SI	yes	yes	
Raw gas pilot endplate set (incl. SI, FR or provision for UV-scanner)	FIG4-FR	yes	no	
	FIG4-UV	yes	no	
In-duct raw gas pilot endplate set (incl. SI, FR or provision for UV-scanner)	FIG5-FR	no	yes	
	FIG5-UV	no	yes	
	FIG5FRCART	no	yes	
	FIG5UV CART	no	yes	
In-duct feed through raw gas pilot endplate set [3]	FIG6-FR	no	yes	
	FIG6-UV	no	yes	
Endplate set (incl. SI, pilot gas connection, and provision for UV scanner)	FIG7-UV	yes	yes	
External mounting plate kit for external UV/FR and external SI	EMP-EXT	no	yes	

Overview of Endplate set options for MAXON APX™ burners (Continued)				
Description	Designation [1]	Wall-mount	In-duct	3D-View
External mounting plate kit for internal UV/FR and internal SI	EMP-INT	no	yes	
In-duct endplate set for direct ignition (incl. SI, FR and provision for UV) [4]	NP-EP SI FR/UV	no	yes	
In-duct plain endplate set [5]	NP-EP PLN	no	yes	

[1] Refer to tables on page 18 and page 19 for information on SI and flame rods included in each endplate.

[2] Use this pilot endplate set on stable back-pressure application only. When fluctuating oven pressures can be expected, use FIG.4.

[3] Select these endplate sets when externally mounted SI and FR/UV are required, or to prevent the use of ignition and/or ionization cable inside the duct (internally mounted SI and FR). To be used together with the external mounting plate sets EXT-MTG.

[4] Direct ignition endplate set to accommodate SI and FR/UV on 1 single endplate set (standard not possible for wall-mounted burners - contact MAXON).

[5] To be selected together with NP-EP SI FR/UV.

## APX™ endplate accessories (included in the endplate assembly)

Accessories included in the endplate sets, except not when explicitly written					
Endplate set	Flame rod	UV-tube [1]	Spark ignitor	Adjustable orifice	Gas test port
FIG1-FR [4]	FR-APX	NA	SI-APX-10mm	AO-3/8" NPT	NA
FIG1-UV [4]	NA	NA	SI-APX-10mm	AO-3/8" NPT	NA
FIG2-FR	FR-APX	NA	NA	NA	1/8" NPT
FIG2-SG	NA	NA	NA	NA	1/8" NPT
FIG2-PLN	NA	NA	NA	NA	1/8" NPT
FIG3-SI	NA	NA	SI-APX-14mm-L	NA	1/8" NPT
FIG4-FR	FR-APX	NA	SI-APX-1/2-14	AO-3/8" NPT	NA
FIG4-UV	NA	UVT-1 [1]	SI-APX-1/2-14	AO-3/8" NPT	NA
FIG5-FR	FR-APX	NA	SI-APX-14mm-S	AO-3/8" NPT [8]	1/8" NPT
FIG5-UV	NA	UVT-2 [1]	SI-APX-14mm-S	AO-3/8" NPT [8]	1/8" NPT
FIG5FRCART	FR-APX	NA	SI-APX-14mm-S	AO-3/8" NPT [8]	1/8" NPT
FIG5UVCART	NA	UVT-2	SI-APX-14mm-S	AO-3/8" NPT [8]	1/8" NPT
FIG6-FR [5]	[2] [5]	NA	[3] [5]	AO-3/8" NPT	1/8" NPT
FIG6-UV [5]	NA	UVT-2 [1]	[3] [5]	AO-3/8" NPT	1/8" NPT
FIG7-UV	NA	UVT-2 [1]	SI-APX-14mm-S	AO-3/8" NPT	1/8" NPT
NP-EP SI FR/UV[6][7]	NA	NA	SI-APX-14mm-L	NA	1/8" NPT
NP-EP PLN [7]	NA	NA	NA	NA	NA

[1] Only applicable for US-supplies (spark excitation).

[2] Select correct flame rod from table "Feed thru flame rods" on page 19.

[3] Select correct spark ignitor from table "Feed thru spark ignitors" on page 18.

[4] These endplate sets include a pilot nozzle and air shutter to adjust the bypass pilot air.

[5] Feed thru endplate sets FIG6 do not include SI/FR. For fresh air applications, standard spark ignitor (SI-APX-10 mm) and standard flame rod (FR-APX) can be selected. Both the standard SI/FR or the feed thru SI/FR have to be added separately.

[6] This endplate set allows direct ignition on in-duct APX™ burners; SI and flame detection can be mounted on this endplate.

[7] For EC-market only.

[8] Endplate tap is 1/4" but a nipple and a reducer (may be shipped loose) allows you to use a 3/8" NPT pilot.

### Process temperature

Max. upstream process air temperature	250 °C
Max. downstream process air temperature at low fire	300 °C
Max. downstream process air temperature at high fire	400 °C

Special attention should be paid when selecting the burner to avoid downstream process air temperatures above 300 °C at low fire. Higher temperatures at minimum burner capacity may dramatically reduce life-time of the burner. At higher capacity, the burner parts are better cooled by the air and gas flow, and allow much higher downstream temperatures.

The slide-in-units APX™ can accept in specific circumstances higher process temperatures, both upstream and downstream of the burner. Contact MAXON for more information.

### Combustion air requirements

MAXON APX™ burners are fed with clean fresh combustion air containing 21 Vol % oxygen and a maximum temperature of 50 °C.

In some installations, the use of higher temperature combustion air, or combustion air containing slightly lower oxygen levels, may be possible. This should be considered case by case. Contact MAXON for more information.



## Modulated or constant combustion air

All MAXON APX™ burners can operate with constant or fixed air flow, as well as with modulated air flow.

At constant air flow, the required differential combustion air pressure (refer to table on page 9, page 10 and page 11) is set by a fixed air damper (burner air inlet or fan) and the combustion air flow through the burner is constant for all burner firing rates (always maximum air flow).

At modulating air flow, an additional air control valve is adjusting the combustion air in function of burner capacity.

The choice of whether constant or modulated air flow should be selected highly depends on the application and the desired emissions on CO and NO<sub>x</sub>. Refer to "Expected Emissions" on page 20 for more details.

## Ratio control

In case the burner is operated with modulated air flow, best performance is realized when the burner is adjusted with ratios as indicated in the table on page 9 and page 10. This can be achieved with MAXON MICRO-RATIO® valves or SMARTLINK® MRV.

Changes of combustion air temperature, system back pressure variations, and other parameters could influence gas/air ratio if the control system is not designed for compensation. Contact MAXON for more information.

## Process air flow velocity and oxygen content

	<b>IN-DUCT (parallel velocity)</b>	<b>WALL- MOUNTED (cross velocity)</b>
Min. process air velocity [1]	2 m/s	2 m/s
Max. process air velocity	8 (20) m/s [2]	6 (9) m/s [3]
Min. process air oxygen level [4]	3 - 6 Vol %	3 - 6 Vol %

[1] A minimum parallel process flow for in-duct burners and cross process flow for wall-mounted burners is required. Burners shall not fire without process flow. Advised minimum velocity shall be above 2 m/s.

[2] Optimal burner performance of in-duct APX™ burners will be realized with a uniform process air velocity around the flame between 2 m/s and 8 m/s. Higher process air velocities are possible (up to 20 m/s), however may influence emissions of CO (see page 20).

[3] Higher cross-velocities (up to 9 m/s will quench the flame and affect emissions (CO). The use of a flame protection shield is advised to limit CO. Contact MAXON for more information.

[4] Depending on temperature, capacity and excess air, MAXON APX™ burners can fire in almost inert process air environment.

## Process back pressures

Max. process back-pressure - wall-mounted APX [1]	-5 mbar to balanced
Max. process back-pressure - in-duct APX [2]	-100 mbar to +100 mbar
Max. process back-pressure - in-duct APX slide-in-unit [3]	-30 mbar to +30 mbar

[1] Wall-mounted burners can only fire in ducts under suction or in balanced atmospheres. Ducts in overpressure should be avoided.

[2] All in-duct burners, except the slide-in-unit design. Special considerations to be taken for the design of combustion air fan in case of higher back-pressures.

[3] Higher back-pressures are possible when the plug and airbox are reinforced. Contact MAXON for more information.

## Piloting & ignition

APX™ burners, equipped with one of the raw gas pilot endplate sets (see table on page 14), will generate a stable pilot flame, used to ignite the burner on main flame. After the main burner is ignited, the pilot shall be interrupted. Permanent pilot is not advised. Use the main burner at minimum capacity for continuous operation.

Direct ignition of APX™ burners is also possible, if accepted by local codes. Note that only in-duct APX™ burners offer direct ignition endplates which accommodate spark ignitor and flame detection in the same endplate set. Direct ignition wall-mounted burners need 1 endplate set for the SI and another endplate set to mount the flame detector.

For both pilot and direct ignition, use ignition transformers min. 5000 V - 20 mA.

## Available spark ignitors

Spark ignitors are included into the pilot endplate sets, except for FIG6 endplates. Refer to table on page 14 for exact information.

Below table will help you with the selection of the appropriate feed thru spark ignitors (in combination with FIG6 endplate set and external mounting plate (EMP)).

Feed thru ignitors with carbon steel tube		Feed thru ignitors with stainless steel tube		Spark ignitors only (without tube)	
12" CS QI	1 ft CS quartz ignitor	12" SS QI	1 ft SS quartz ignitor	12" QI L/T	1 ft quartz ignitor
18" CS QI	1,5 ft CS quartz ignitor	18" SS QI	1,5 ft SS quartz ignitor	18" QI L/T	1,5 ft quartz ignitor
24" CS QI	2 ft CS quartz ignitor	24" SCS QI	2 ft SS quartz ignitor	24" QI L/T	2 ft quartz ignitor
30" CS QI	2,5 ft CS quartz ignitor	30" SS QI	2,5 ft SS quartz ignitor	30" QI L/T	2,5 ft quartz ignitor
36" CS QI	3 ft CS quartz ignitor	36" SS QI	3 ft SS quartz ignitor	36" QI L/T	3 ft quartz ignitor
48" CS QI	4 ft CS quartz ignitor	48" SS QI	4 ft SS quartz ignitor	48" QI L/T	4 ft quartz ignitor



Select your spark ignitor in function of the required length (1 ft to 4 ft in steps of 0,5 ft).

## Typical ignition sequence (with pilot)

- Pre-purge of burner and combustion chamber, according to the applicable codes and the installation's requirements.
- Gas control valve shall be in the minimum position.
- APX burners with modulated combustion air shall have the combustion air valve (linked with the gas control valve) also in the corresponding minimum position to allow minimum combustion air flow to the burner.
- Pre-ignition (typically 2 s sparking in air).
- Open pilot gas and continue to spark the ignitor (typically 5 s to 10 s depending on local code requirements).
- Stop sparking, continue to power the pilot gas valves and start flame check. Trip burner if no flame detected from here on.
- Check pilot flame stability (typically 5 s to 10 s to prove stable pilot).
- Open main gas valves and allow enough time to have main gas in the burner (typically 5 s + time required to have main gas in the burner).
- Close the pilot gas valves.
- Release to modulation (allow modulation of the burner).

Above sequence shall be completed to include all required safety checks during the start of the burner (process & burner safeties). We advise to position 1 pilot gas valve as close as possible to the pilot burner gas inlet for fast ignition of the pilot burner.

## Flame supervision

The flame of APX™ burners can be supervised with a flame rod or UV-scanner.

Depending on the application, different versions of endplate sets accommodating different types of flame rods can be selected. Refer to table page 14 (Overview of endplate set options) and table page 16 (APX™ accessories) for more information.

For poor quality propane, LPG or butane, we advise to use UV-scanners only.

Only use the appropriate positions on the MAXON endplate sets for correct and safe flame supervision. Every other position is not acceptable and may cause unsafe situations.

Refer to the user manual of the UV-scanner for correct installation and operating instructions.

## Available flame rods

Also flame rods are included into the pilot endplate sets, except for FIG6 endplates. Refer to table page 14 for exact information.

Below table will help you with the selection of the appropriate feed thru flame rods (in combination with FIG6 endplate set and external mounting plate (EMP)).

Feed thru ignitors with carbon steel tube		Feed thru ignitors with stainless steel tube		Spark ignitors only (without tube)	
12" CS FR	1 ft CS quartz flame rod	12" SS FR	1 ft SS quartz flame rod	12" FR L/T	1 ft quartz flame rod
18" CS FR	1,5 ft CS quartz flame rod	18" SS FR	1,5 ft SS quartz flame rod	18" FR L/T	1,5 ft quartz flame rod
24" CS FR	2 ft CS quartz flame rod	24" SCS FR	2 ft SS quartz flame rod	24" FR L/T	2 ft quartz flame rod
30" CS FR	2,5 ft CS quartz flame rod	30" SS FR	2,5 ft SS quartz flame rod	30" FR L/T	2,5 ft quartz flame rod
36" CS FR	3 ft CS quartz flame rod	36" SS FR	3 ft SS quartz flame rod	36" FR L/T	3 ft quartz flame rod
48" CS FR	4 ft CS quartz flame rod	48" SS FR	4 ft SS quartz flame rod	48" FR L/T	4 ft quartz flame rod



Select your flame rod in function of the required length (1 ft to 4 ft in steps of 0,5 ft).

## Flame development

Tables page 9, page 10 and page 11 are giving typical flame length of MAXON APX™ burners for the shown combustion air amount, burner capacity and application (fresh air versus recirculating air).

Note that flame length is influenced by different factors, such as:

- Excess air factor (higher excess air will reduce flame length)
- Process air velocity (higher velocity will reduce flame length)
- Type of fuel (butane flames will typically be longer than natural gas flames)
- Burner length (shorter burners will give shorter flame lengths)
- Air distribution at the burner inlets - see "Piping" below.

In case the burner is fired with low excess air in low oxygen environment, flame may become quite radiant.

Take this into consideration for the design of combustion chambers (choice of materials, distance to the wall, expansion allowance).

Contact MAXON for more information.

## Piping

---

Except for the slide-in-units where the air and gas distribution is incorporated into the burner design, special attention should be paid to the execution of air and gas manifolds feeding the air and gas inlet(s) of all the other APX™ burner versions.

Common engineering practice should be followed to equally feed the burner at each air and gas connection. Prevent too high velocities which may cause unequal pressure build-up. Burner and piping shall be independently supported to allow for thermal expansion, to prevent any stress on the burner inlets and to prevent the transmission of vibrations.

## Fuels

---

MAXON APX™ burners can fire natural gas, propane, butane and LPG and are able to fire multiple fuels simultaneously, if the control system is properly designed.

Alternative fuels may be possible. Contact MAXON for more information.

## Expected Emissions

---

The clean hot air generated by MAXON APX™ burners meets most of the local requirements of make-up air systems, over the full turndown of the burners.

Also in low temperature ovens and drying systems, MAXON APX™ burners are able to fire with both low NO<sub>x</sub> and CO, over its entire turndown, meeting the most stringent local emission requirements.

The production of pollutants can be highly dependant upon burner application and installation. Differing temperatures, process velocities, oxygen levels, fuels and other process related factors such as unequal process air distribution can all influence the actual level of emissions produced.

No guarantee of emissions is intended or implied on the above.

Contact MAXON for evaluation of expected emissions on your typical application.

## Dimensions and weights

### 0.5 ft packaged blower

This burner version includes a combustion air blower. This version is not suitable for the EC-market.

- 1) Combustion air blower
- 2) Main gas inlet flange 1" NPT
- 3) Spark ignitor
- 4) Flame rod
- 5) Burner mounting plane

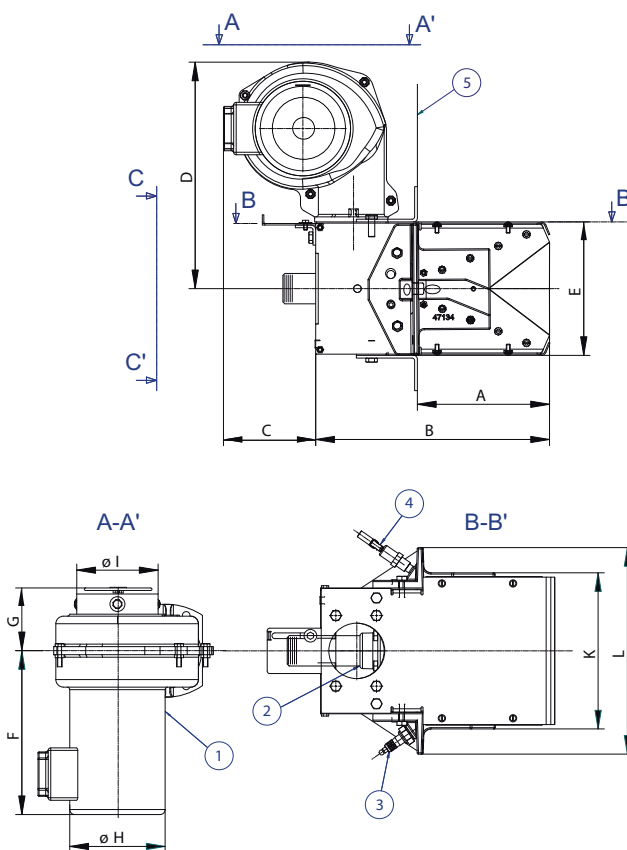

Dimensions in mm unless stated otherwise										
A	B	C	D	E	F	G	ØH	ØI	K	L
165	292	114	284	168	206	78,7	119	102	196	259

### Mounting arrangements (view C-C')

Continuous flange mounting

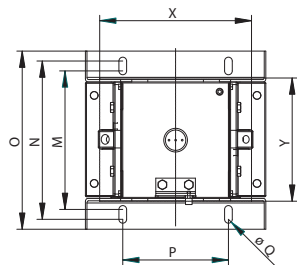

Slot mounting

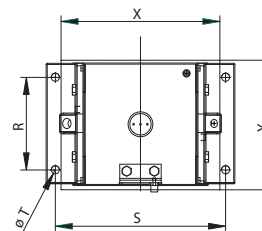

Dimensions in mm unless stated otherwise									
M	N	O	P	ØQ	R	S	ØT	X	Y
201	229	257	152	11	127	234	11	218	178

1 ft to 15 ft external blower

- 1) Air inlet + shutter
- 2) Test connection
- 3) Mounting surface
- 4) Gas inlet flange 1-1/2" NPT

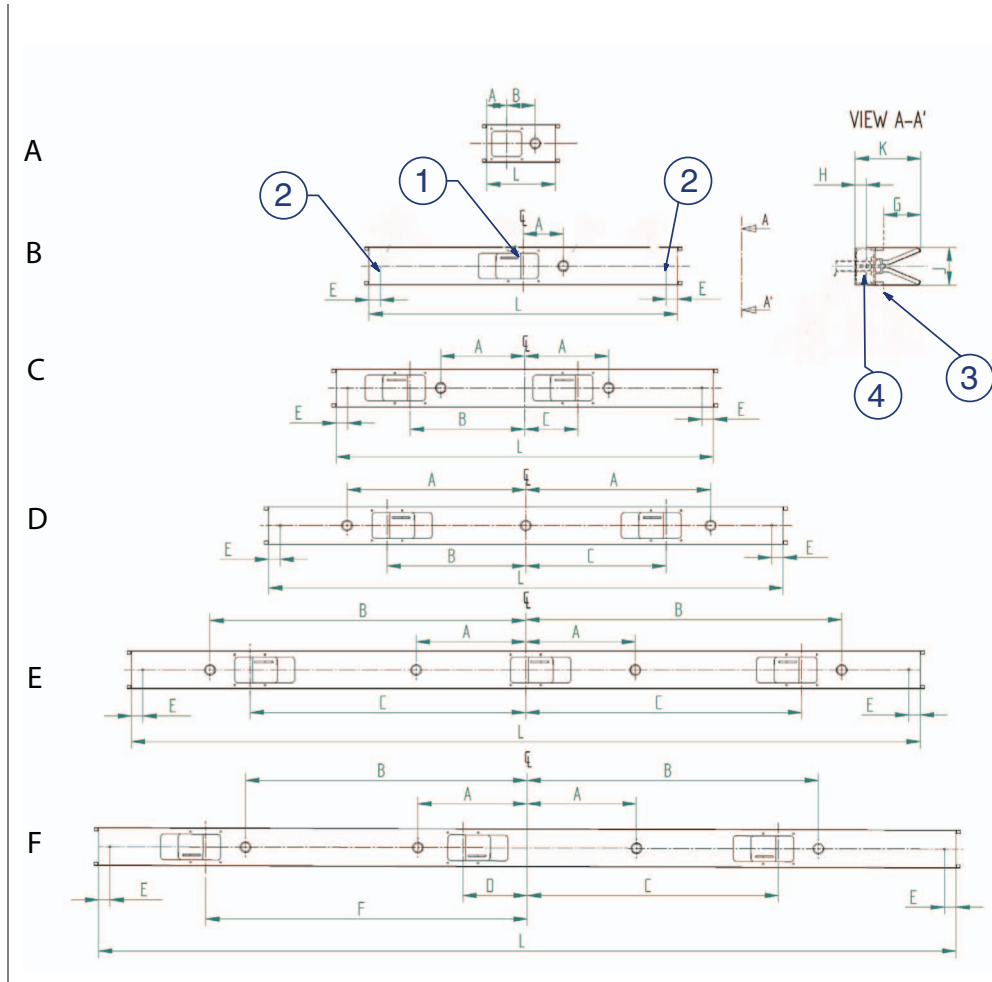

Dimensions in mm unless stated otherwise																		
burner size (ft)	1	1.5	2	2.5	3	3.5	4	5	6	7	8	9	10	11	12	13	14	15
sketch	A	B	B	B	B	B	B	B	C	C	D	D	D	D	E	F	F	E
A	93	178	178	178	178	178	178	178	635	457	914	914	914	914	457	457	457	533
B	127	-	-	-	-	-	-	-	457	635	737	632	737	737	1372	1372	1372	1600
C	-	-	-	-	-	-	-	-	457	279	737	610	737	1092	1193	1194	1194	1422
D	-	-	-	-	-	-	-	-	-	-	-	-	-	-	-	279	279	-
E	-	51	51	51	51	51	51	51	51	51	51	51	51	51	51	51	51	51
F	-	-	-	-	-	-	-	-	-	-	-	-	-	-	-	1549	1549	-
G	165	165	165	165	165	165	165	165	165	165	165	165	165	165	165	165	165	165
H	50	50	50	50	50	50	50	50	50	50	50	50	50	50	50	50	50	50
J	168	168	168	168	168	168	168	168	168	168	168	168	168	168	168	168	168	168
K	292	292	292	292	292	292	292	292	292	292	292	292	292	292	292	292	292	292
L	343	495	648	800	952	1104	1257	1562	1867	2172	2476	2781	3086	3391	3696	4000	4305	4610
weight (kg)	6	9	12	15	19	22	25	31	37	43	50	56	62	68	74	81	87	93



WWW.MAXONCORP.COM

COMBUSTION SYSTEMS FOR INDUSTRY

Maxon reserves the right to alter specifications and data without prior notice.

© 2016 Copyright Maxon Corporation. All rights reserved.

1 to 15 ft packaged blower (not for EC-market)

This modular straight burner includes one or more combustion air blowers. This version is not suitable for the EC-market. The packaged burner dimensions are the same as those of the “external blower” version, see page 22.

Additional to the “external blower” version, the packaged version has one or more combustion air blowers mounted directly on the back of the burner. For positions of these combustion air inlets see page 22. For dimensions of blowers, see page 36.

APX™ "H" Style burners - slot fired mounting

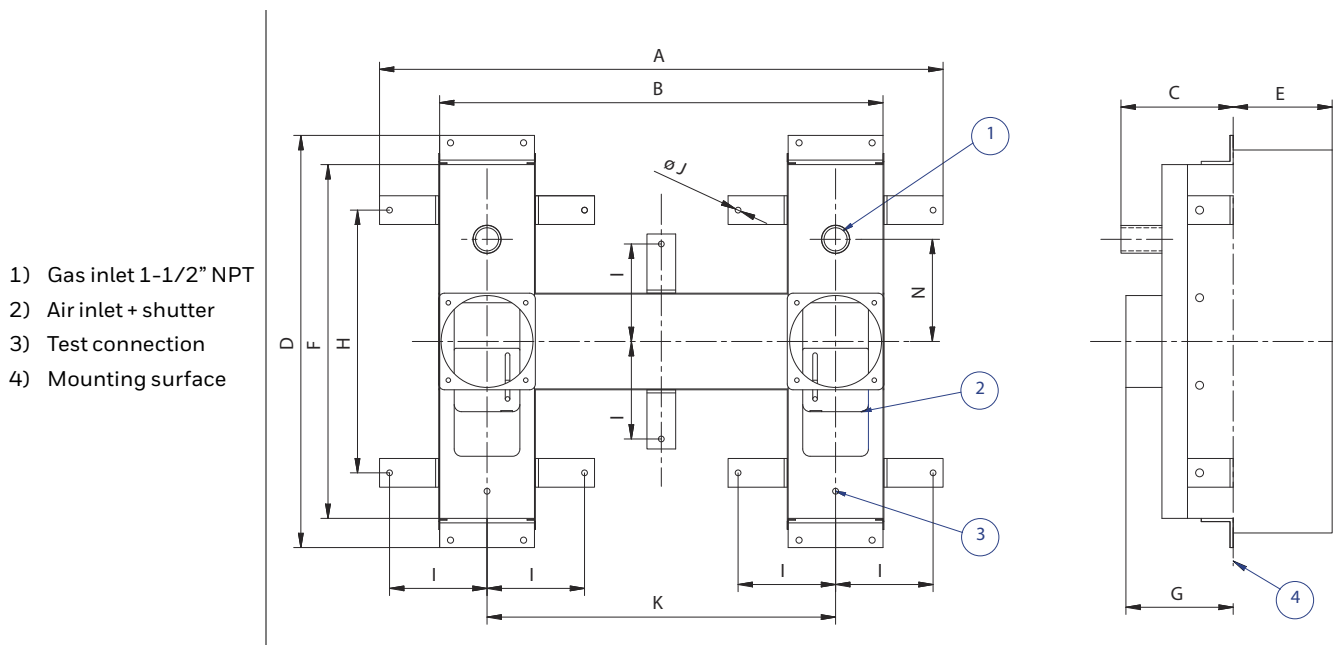

- 1) Gas inlet 1-1/2" NPT
- 2) Air inlet + shutter
- 3) Test connection
- 4) Mounting surface

Dimensions in mm unless stated otherwise													
Burner size	A	B	C	D	E	F	G	H	I	ØJ	K	N	Weight (kg)
1 x 1	676	470	191	412	164	311	203	152	170	10	305	64	19
1 x 1.5	829	622	191	412	164	311	203	152	170	10	457	64	22
1 x 2	981	775	191	412	164	311	203	152	170	10	610	64	25
1 x 2.5	1133	927	191	412	164	311	203	152	170	10	762	64	28
2 x 1	676	470	191	717	164	616	203	457	170	10	305	178	31
2 x 1.5	829	622	191	717	164	616	203	457	170	10	457	178	34
2 x 2	981	775	191	717	164	616	203	457	170	10	610	178	37
2 x 2.5	1133	927	191	717	164	616	203	457	170	10	762	178	40
3 x 1	676	470	191	1022	164	920	203	762	170	10	305	178	43
3 x 1.5	829	622	191	1022	164	920	203	762	170	10	457	178	47
3 x 2	981	775	191	1022	164	920	203	762	170	10	610	178	50
3 x 2.5	1133	927	191	1022	164	920	203	762	170	10	762	178	53
3 x 3.5	1438	1232	191	1022	164	920	203	762	170	10	1067	178	59

## APX™ "H" Style burners - universal mounting

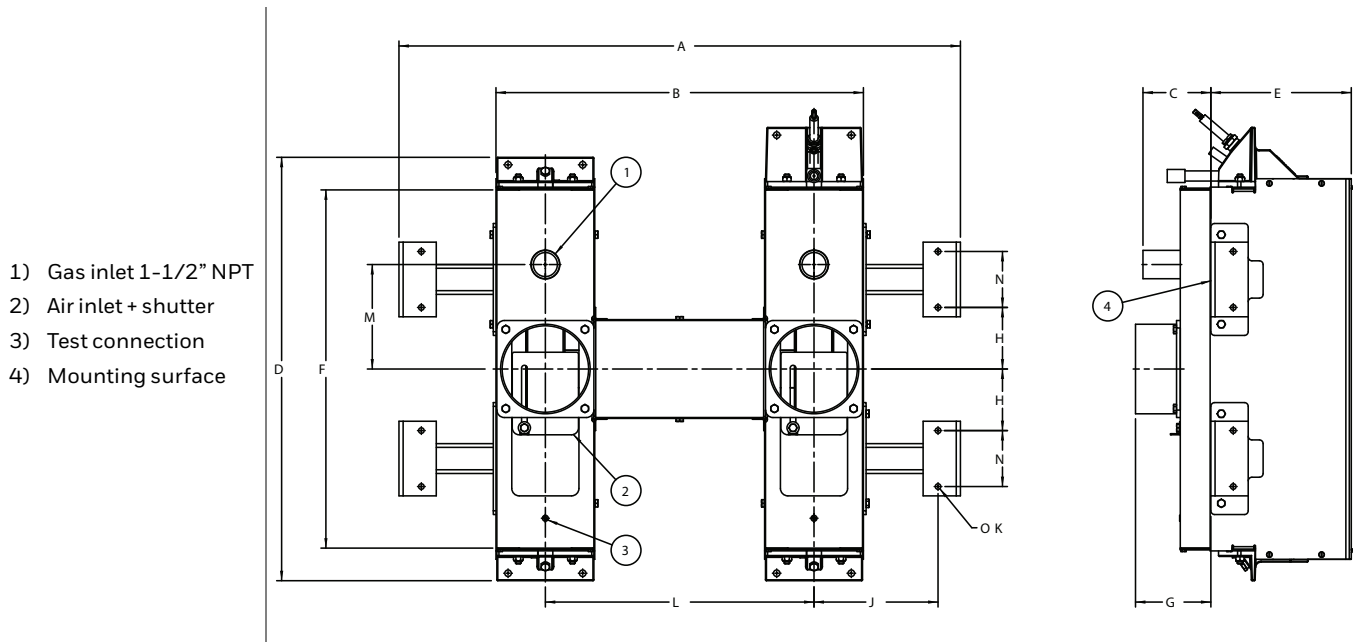

Dimensions in mm unless stated otherwise

Burner size	A	B	C	D	E	F	G	H	J	Ø K	L	M	N	Weight (kg)
1 x 1	803	470	114	412	239	311	130	16	211	10	305	64	97	19
1 x 1.5	956	622	114	412	239	311	130	16	211	10	457	64	97	22
1 x 2	1108	775	114	412	239	311	130	16	211	10	610	64	97	25
1 x 2.5	1260	927	114	412	239	311	130	16	211	10	762	64	97	28
2 x 1	803	470	114	717	239	616	130	104	211	10	305	178	97	31
2 x 1.5	956	622	114	717	239	616	130	104	211	10	457	178	97	34
2 x 2	1108	775	114	717	239	616	130	104	211	10	610	178	97	37
2 x 2.5	1260	927	114	717	239	616	130	104	211	10	762	178	97	40
3 x 1	803	470	114	1022	239	920	130	257	211	10	305	178	97	43
3 x 1.5	956	622	114	1022	239	920	130	257	211	10	457	178	97	47
3 x 2	1108	775	114	1022	239	920	130	257	211	10	610	178	97	50
3 x 2.5	1260	927	114	1022	239	920	130	257	211	10	762	178	97	53
3 x 3.5	1565	1232	114	1022	239	920	130	257	211	10	1067	178	97	59



APX™ Slide-in-units

- 1) Gas inlet
- 2) Pilot gas connection 1/2"
- 3) Combustion air test connection 1/4"
- 4) Gas test connection 1/4"
- 5) Burner support (custom made)
- 6) Burner mounting plug (custom made - drawing shows typical layout)
- 7) Mounting plate to be used in case of external ignitor and flame scanner option

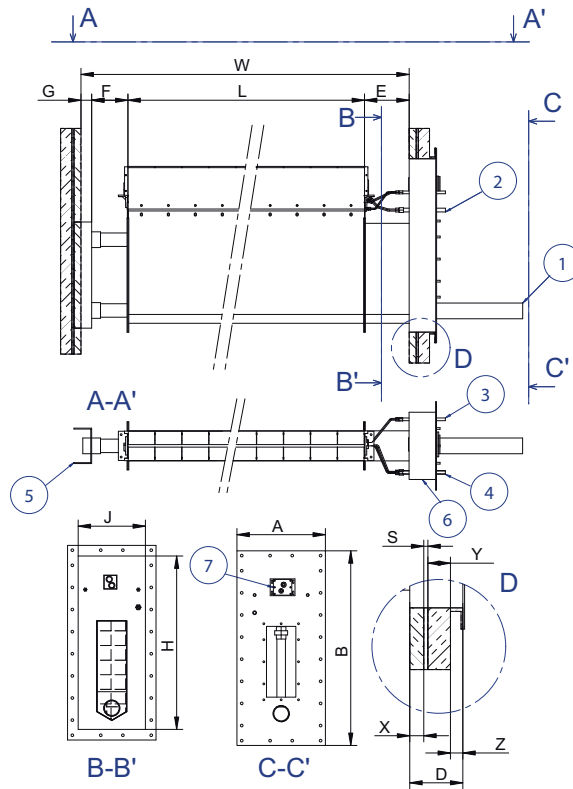

Dimensions in mm unless stated otherwise															
Burner size	0,5	1	1,5	2	2,5	3	3,5	4	4,5	5	5,5	6	6,5	7	7,5
L	152	305	457	610	762	914	1067	1219	1372	1524	1676	1829	1981	2134	2286
Gas inlet [1]	1"	1"	1 1/2"	1 1/2"	1 1/2"	1 1/2"	2"	2"	2"	2"	2 1/2"	2 1/2"	2 1/2"	2 1/2"	2 1/2"
A	420	420	420	420	420	420	420	420	420	420	420	420	420	520	520
B	620	620	720	720	720	720	920	920	920	920	920	920	920	1120	1120
J [2]	300	300	300	300	300	300	300	300	300	300	300	300	300	400	400
H [2]	500	500	600	600	600	600	800	800	800	800	800	800	800	1000	1000
weight (kg)	59	67	72	79	84	90	110	116	122	128	134	140	177	184	192

Dimensions in mm, unless stated otherwise															
Burner size	8	8,5	9	9,5	10	10,5	11	11,5	12	12,5	13	13,5	14	14,5	15
L	2438	2591	2743	2896	3048	3200	3353	3505	3658	3810	3962	4115	4267	4420	4572
Gas inlet[1]	3"	3"	3"	3"	3"	3"	3"	3"	4"	4"	4"	4"	4"	4"	4"
A	520	520	520	520	520	520	520	520	520	520	520	520	520	520	520
B	1120	1120	1120	1120	1120	1120	1120	1120	1320	1320	1320	1320	1320	1320	1320
J [2]	400	400	400	400	400	400	400	400	400	400	400	400	400	400	400
H [2]	1000	1000	1000	1000	1000	1000	1000	1000	1200	1200	1200	1200	1200	1200	1200
weight (kg)	200	207	214	260	270	280	287	296	325	334	343	352	361	371	378

[1] Gas inlet connection standard ISO-threaded for sizes up to and including 2". Larger sizes standard have DIN PN10 flanged connections. NPT threaded and ANSI 150lbs flanges available on request.  
 [2] Plug to be mounted in an opening with min. dimensions J x H

For complete burner dimension information, the following application dependent dimensions should be defined:

W:	internal duct width	S:	duct wall thickness
D:	max. 600 mm ( $D = X + Y + Z + S$ )	E:	min. 150 mm
X:	internal insulation thickness	F:	min. 150 mm
Y:	external insulation thickness	G:	default $G = X$
Z:	flange elevation (default = 100 mm)		

### Wall mounting: opening dimensions

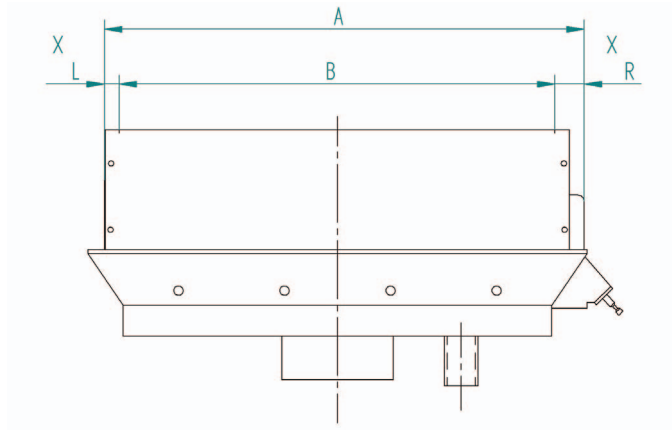

A = wall opening, width  
wall opening height = 7 in.

B = burner nominal length (refer to burner dimensions on page 21)

XL = endplate width mounted on left side of the burner

XR = endplate width mounted on right side of the burner

$A = B + XL + XR$

XL and XR depend on the endplate type. Use the table below for determination.

Note that Fig. 1 endplates need a special wall opening shape if full seal is required. Contact MAXON for details.

Dimensions in mm unless stated otherwise	
Endplate Fig. #	X
1	55
2, 3, 4, 5, 6	34
4	76

Mounting flange dimensions

Use this sketch to determine fixing points for flange mounted burner parts.

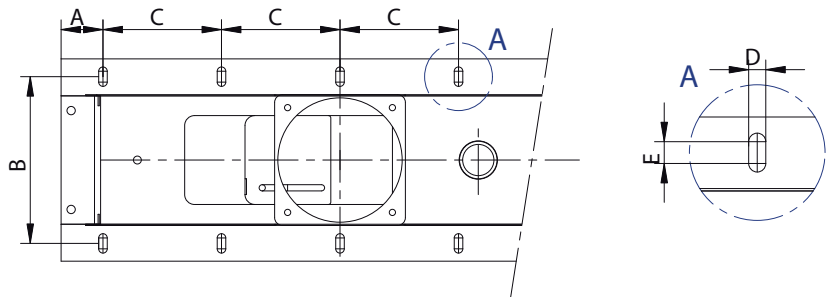

Dimensions in mm unless stated otherwise				
A	B	C	ØD	ØE
53	213	152	11	14

Slot mounting tabs

These support tabs can be mounted at various locations on the burner body at 152 mm spacings. They are suggested to be used for burners longer than 4 ft. Burners with a maximum length of 4 ft can be supported using the fixation holes in the endplates.

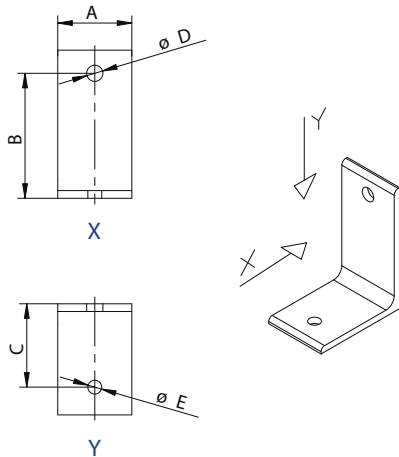

Dimensions in mm unless stated otherwise				
A	B	C	ØD	ØE
51	86	57	11	10

## Universal mounting bracket

These brackets can be used to support burners in horizontal orientation (use 1 bracket per 5 ft burner) and in vertical orientations (use 1 bracket per 3 ft burner and install brackets on both sides of the burner).

- 1) Mounting surface to be attached to burner

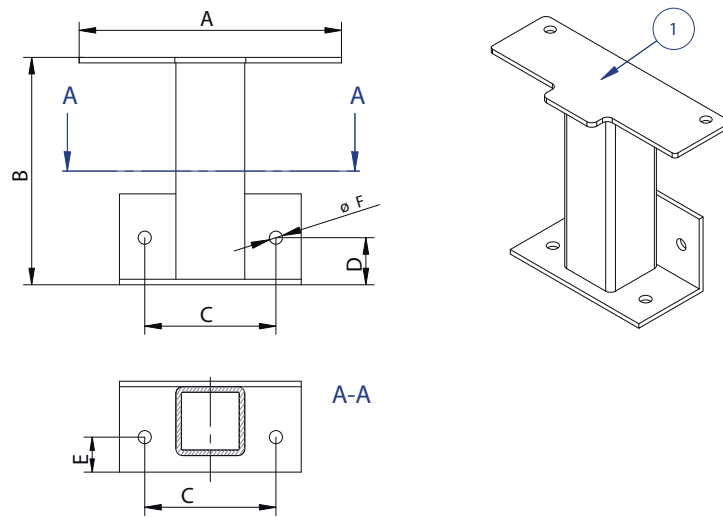

**Dimensions in mm unless stated otherwise**

A	B	C	D	E	ØF
191	165	95	34	25	10

## Endplates

### FIG 1

- 1) Spark ignitor connection M10x1
- 2) UV/flame rod connection 1" NPT
- 3) Pilot gas connection 3/4-16 UNF
- 4) Flame rod
- 5) Mounting surface
- 6) Pilot air shutter

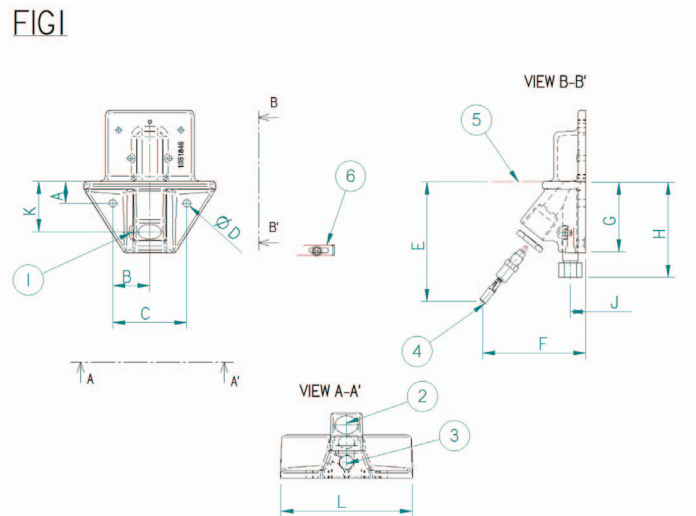

**Dimensions in mm unless stated otherwise**

A	B	C	ØD	E [1]	F [1]	G	H	J	K	L
28	46	91	9	274	239	86	152	20	64	165

[1] Clearance for flame rod removal

FIG 2

- 1) Flame rod connection 1-1/4" NPT
- 2) Flame rod
- 3) Optional sight glass
- 4) Gas test connection 1/8" NPT
- 5) Mounting surface

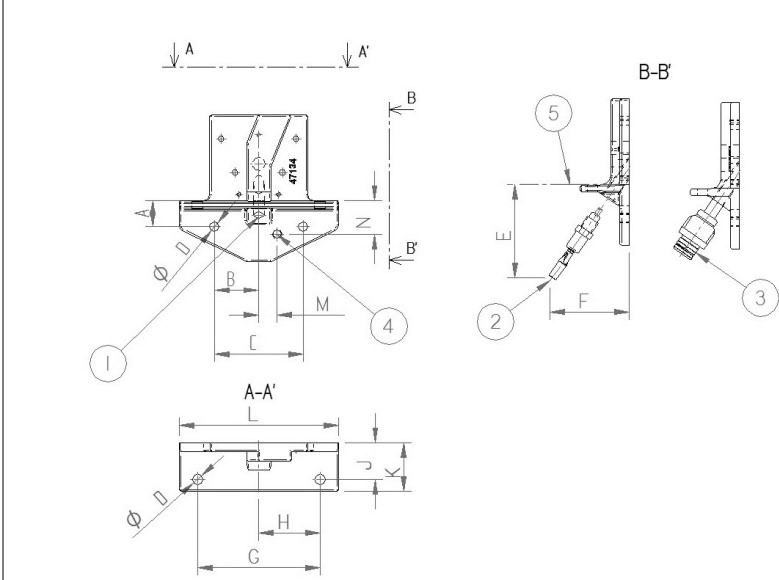

Dimensions in mm unless stated otherwise												
A	B	C	ØD	E [1]	F [1]	G	H	J	K	L	M	N
28	46	91	9	236	175	127	64	38	51	165	20	36

[1] Clearance for flame rod removal

FIG 3

- 1) Spark ignitor connection M14x1.25
- 2) Spark ignitor
- 3) Gas test connection 1/8" NPT
- 4) Mounting surface

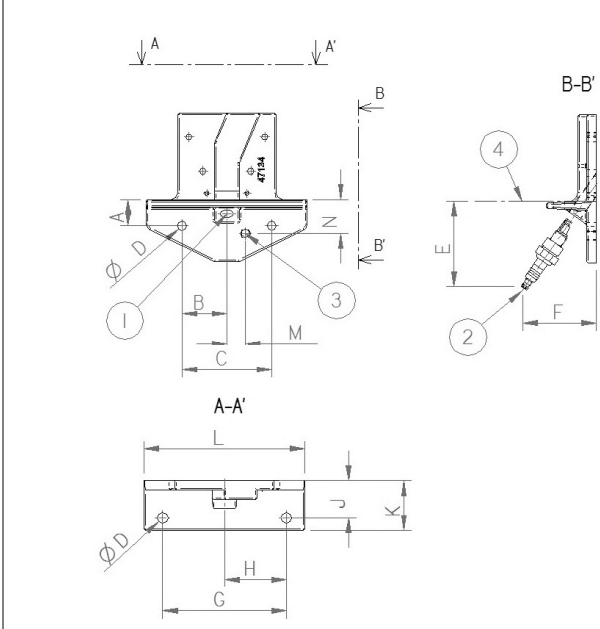

Dimensions in mm unless stated otherwise												
A	B	C	ØD	E [1]	F [1]	G	H	J	K	L	M	N
28	46	91	9	84	69	127	64	38	51	165	20	36

[1] Clearance for spark ignitor removal

FIG 4

- 1) Spark ignitor connection 3/4"-16
- 2) UV/flame rod connection 1/4"NPT
- 3) Pilot gas connection 3/8"NPT
- 4) Flame rod
- 5) Mounting surface
- 6) Pilot gas adjusting needle valve

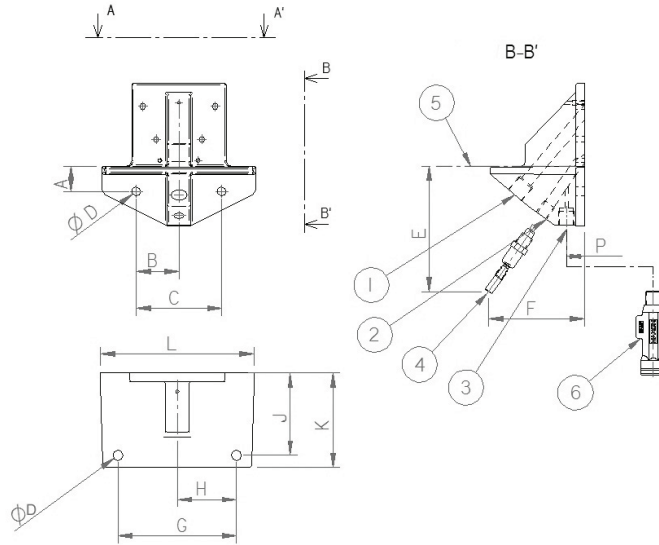

Dimensions in mm unless stated otherwise

A	B	C	ØD	E [1]	F [1]	G	H	J	K	L	P
28	46	91	9	272	201	127	64	89	102	165	20

[1] Clearance for flame rod removal

FIG 5

- 1) Spark ignitor connection M14x1.25
- 2) UV/flame rod connection 1/4"NPT [1]
- 3) Pilot gas connection 1/4"NPT [1]
- 4) Flame rod
- 5) Mounting surface
- 6) Gas test connection 1/8"NPT

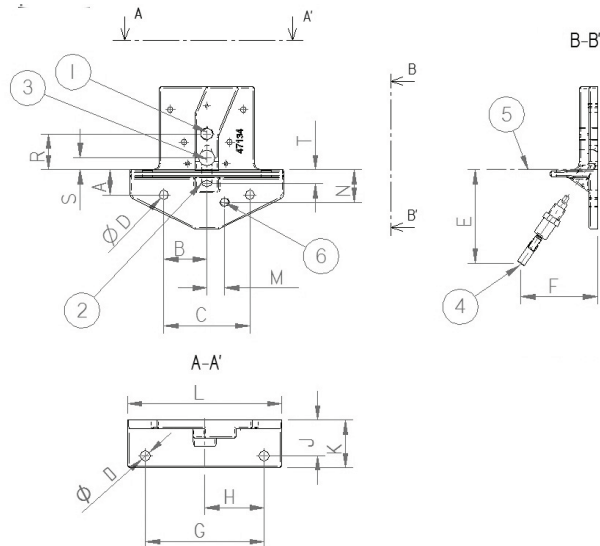

[1] NOTE : a 3/8" adjustable orifice is still used along with a nipple and a reducer.

NOTE : FIG5FRCART and FIG5UVCART have an extra hole for a customer supplied cartridge heater.

Dimensions in mm unless stated otherwise

A	B	C	ØD	E [1]	F [1]	G	H	J	K	L	M	N	R	S	T
28	46	91	10	236	175	127	64	38	51	165	20	36	38	13	15

[1] Clearance for flame rod removal

FIG 6

- 1) Spark ignitor connection 3/4" - 10UNC
- 2) UV/flame rod connection 3/4" - 10UNC
- 3) Pilot gas or local flame rod connection 1/4" NPT
- 4) Flame rod
- 5) Mounting surface
- 6) Gas test connection 1/8" NPT

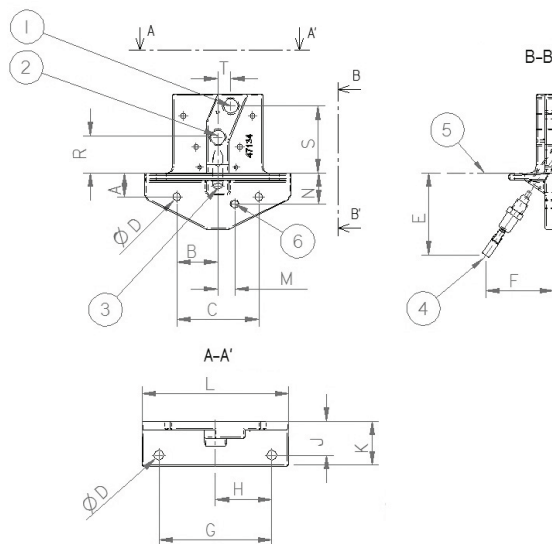

Dimensions in mm unless stated otherwise															
A	B	C	ØD	E [1]	F [1]	G	H	J	K	L	M	N	R	S	T
28	46	91	10	234	178	127	64	38	51	165	20	36	42	75	15

[1] Clearance for flame rod removal

FIG 7

- 1) Spark ignitor connection M14 x 1.25
- 2) Pilot gas connection 3/8" NPT
- 3) UV scanner connection 1/4" NPT
- 4) Gas test connection 1/8" NPT

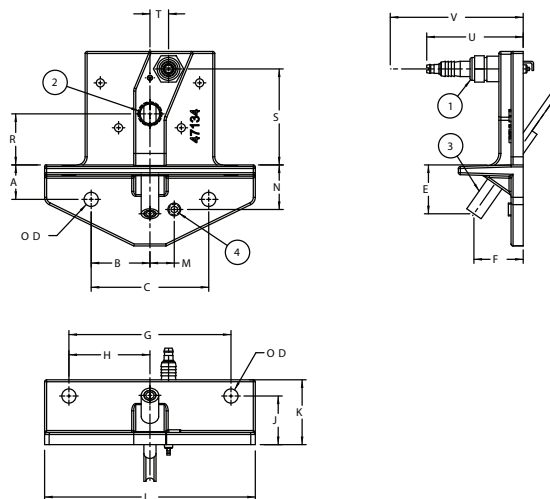

Dimensions in mm unless stated otherwise																	
A	B	C	ØD	E	F	G	H	J	K	L	M	N	R	S	T	U	V [1]
28	46	91	10	38	38	127	64	38	51	165	20	36	42	75	15	75	104

[1] Clearance for spark ignitor removal

**IN-DUCT ENDPLATE SET**

- 1) Scanner connection Rp1/2"  
Flame rod connection Rp1/4"  
(bushed)
- 2) Spark ignitor connection M14x1.25
- 3) Pilot gas connection Rp 1/4"
- 4) Gas test connection 1/8"NPT
- 5) Combustion air test connection 1/8"  
NPT

A = 292 mm

B = 165 mm

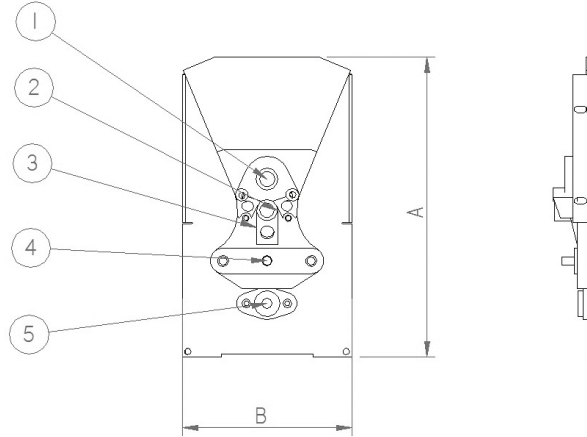
**IN-DUCT PLAIN ENDPLATE SET**

- 1) Gas test connection 1/8"NPT
- 2) Combustion air test connection 1/8"  
NPT

A = 292 mm

B = 165 mm

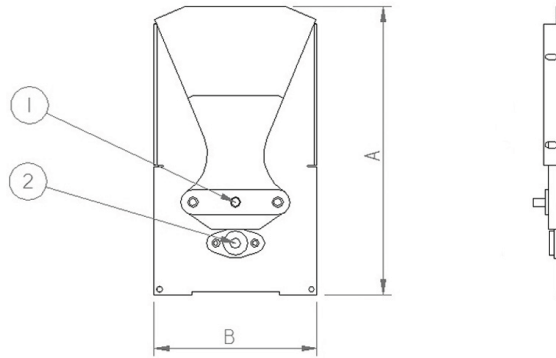



Flame rod - FR-APX

1) 1/4" - 18 thread

Dimensions in mm unless stated otherwise		
A	B	ØC
245	191	5

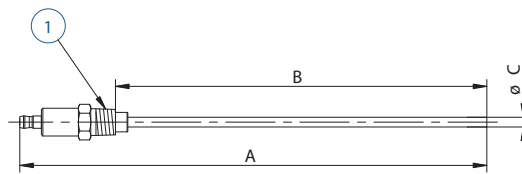

Flame rod - FR-Quartz

for use with external mounting plate kit.

Dimensions in mm unless stated otherwise		
Size	A	ØB
12"	305	25,4
18"	457	25,4
24"	610	25,4
30"	762	25,4
36"	914	25,4
48"	1220	25,4

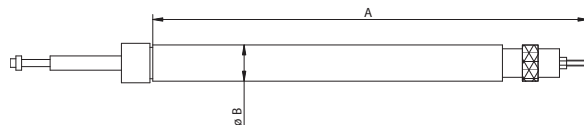

Spark ignitor - SI-APX-10 mm

1) 10 mm thread

Dimensions in mm unless stated otherwise			
A	B	C	D
70	6	10	3

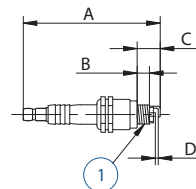

Spark ignitor - SI-APX-14 mm-Long

1) 14 mm thread

Dimensions in mm unless stated otherwise			
A	B	C	D
104	13	47	2

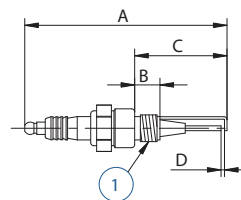

Spark ignitor - SI-APX-14 mm-Short

1) 14 mm thread

Dimensions in mm unless stated otherwise			
A	B	C	D
84	13	27	2

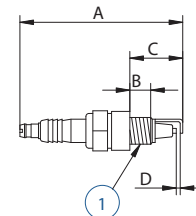

## Spark ignitor - SI-APX-1/2-14

1) 1/2"-14 thread

Dimensions in mm unless stated otherwise				
A	B	C	D	ØE
165	140	32	10	14

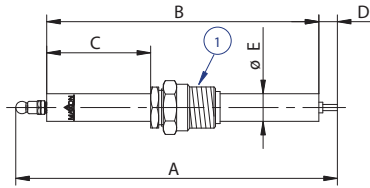

## Spark ignitor - quartz less tube

Dimensions in mm unless stated otherwise		
A	B	ØC
213	165	12

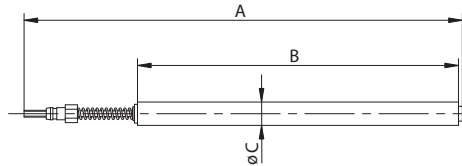

## Spark ignitor - quartz with tube

Available in different sizes. Each size available in either carbon steel or stainless steel.

Dimensions in mm unless stated otherwise		
Size	A	ØB
12"	305	25,4
18"	457	25,4
24"	610	25,4
30"	762	25,4
36"	914	25,4
48"	1220	25,4

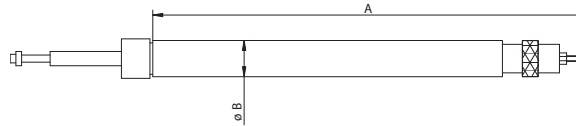

Mounting plate kits for spark ignitor and flame detection

External SI/UV

- 1) Gasket
- 2) Cover plate
- 3) Sealing plate

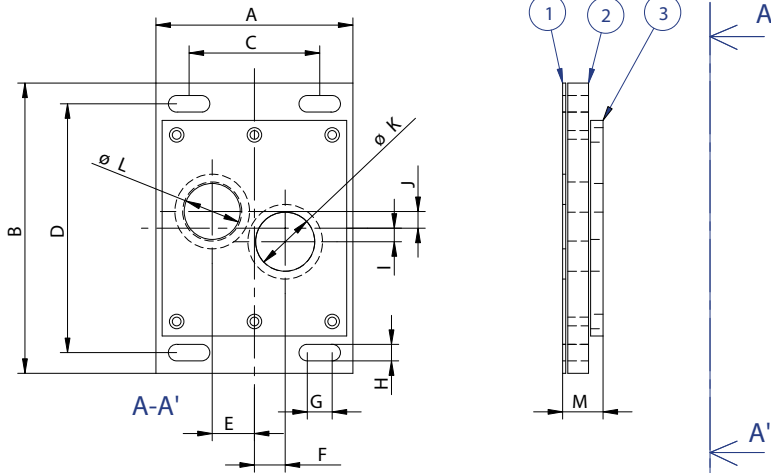

Dimensions in mm unless stated otherwise													
A	B	C	D	E	F	G	H	I	J	ØK	ØL	M	Weight (kg)
95	140	63	120	20,4	14,8	12	8	6,5	8,1	28,5	28,5	19,5	1,2

Internal SI/UV

- 1) Gasket
- 2) Cover plate

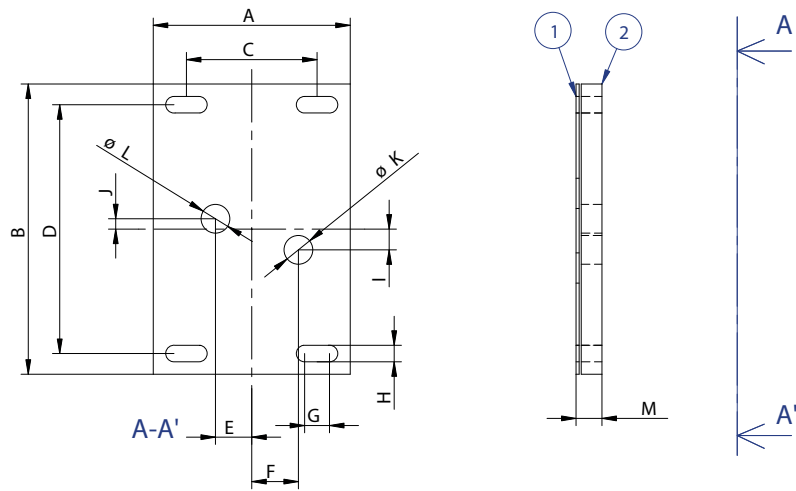

Dimensions in mm unless stated otherwise													
A	B	C	D	E	F	G	H	I	J	ØK	ØL	M	Weight (kg)
95	140	63	120	17,5	22,5	12	8	10	5	P <sub>9</sub> 9	P <sub>9</sub> 9	12,5	1

Blowers and accessories

- 1) Blower
- 2) Filter
- 3) Silencer

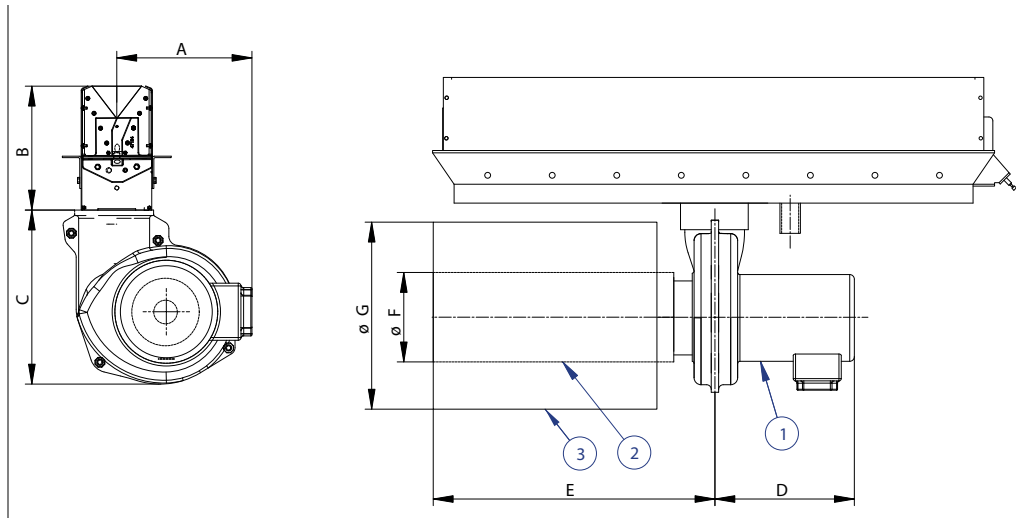

Dimensions in mm unless stated otherwise							
Burner size ft	A	B	C	D	E	ØF	ØG
1	323	292	386	366	516	178	300
1.5	323	292	386	366	516	178	300
2	417	292	483	371	521	178	300
2.5 through 15	417	292	483	371	706	229	417

Adjustable pilot gas orifice

- 1) Gas outlet 3/8" NPT
- 2) Gas inlet 3/8" NPT
- 3) Protection cap: remove to access flow adjustment screw HEX 3.8 mm

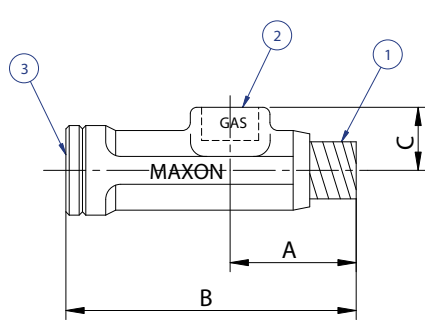

- A = 38 mm
- B = 87,5 mm
- C = 19 mm

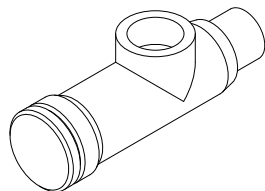

## Installation and operating instructions

### Application requirements

#### View Port

---

A view port to inspect burner flame is essential to inspect flame aspect. It is recommended to install the view port downstream of the flame, such that the entire burner front can be observed, as well as the pilot burner.

#### Required ancillary equipment

---

Ensure that all required ancillary equipment for safe operation and correct performance of the APX™ burner is installed as described in the applicable codes and/or process-related instructions.

#### Position of the burner in the process flow

---

MAXON APX™ burners are designed for heating of a process flow in motion. Refer to table page 9 for minimum required process air velocity for in-duct and wall-mounted APX™ burners.

In-duct APX™ burners should be mounted so as to direct their flames parallel to and in the same direction as the movement of the process flow.

Wall mounted burners can be mounted perpendicular to the process flow, as long as the minimum and maximum velocities as indicated in table page 9 are respected. Too high velocities may result in diverged flame patterns, damaging combustion chamber or oven walls.

In both cases, the process flow upstream of the burner should be uniform (maximum deviation of velocity of approx. 20% in 90% of the points of a plane immediately in front of the burners).

#### Combustion chamber

---

APX™ burners may have in specific operating conditions (low oxygen or inert process air flows) quite luminous and radiant flames.

Special attention should be paid to the part of the duct covering the flame (combustion chamber). Especially in narrow ducts with flames close to the wall, it is essential to use correct materials and proper construction designs. Contact MAXON for more information.

## Installation instructions

### Storage

---

APX™ burners should be stored dry (inside). Prevent that water and/or dust can penetrate into the burner manifold during storage.

### Handling

---

APX™ burners are shipped as complete units. Handle the burner with care during unpacking, transport, lifting and installation. Use proper equipment. Any impact on the burner could result in damage.

Remove all plastic caps closing off gas and air connections of the burner prior to connecting it with the pipe-train and combustion air fan.

### Orientation

---

APX™ burners can be mounted in any orientation (firing horizontally / vertically down and upwards).

### Mounting

---

APX™ burners are equipped with a continuous mounting flange or with mounting tabs (see drawings on page 26 and page 27). Bolt the burner with this flange or mounting tabs onto the oven or duct. Tighten the bolts with correct torque and retighten all bolts after first firing and regularly after commissioning. Since wall-mounted APX™ burners are foreseen to operate under suction or in balanced atmospheres, the use of gaskets is not absolutely required, however not prohibited.

Standard in-duct APX™ burners (ID-PB & ID-EB) are hung in the duct with the mounting tabs as shown on drawings page 23 and page 27.

In-duct plug & play burners are equipped with a mounting plate or plug (see drawings page 25 and page 27). Bolt this mounting plug or plate onto the combustion chamber's mounting flange. Use proper gasket (available as an option). Tighten the bolts with correct torque and retighten all bolts after first firing and regularly after commissioning.

Use only the APX™ burner support supplied by MAXON for supporting the burner at the opposite side of the mounting plate/plug. This support is especially designed to give the burner sufficient flexibility during firing. Use of different kind of supports may damage or destroy the burner.

Refer to drawings on page 23 and page 25 for correct position of the burner support.

### Hot surfaces

---



Burner parts in contact with the flame will become hot. Always wait for the burner system to cool down before cleaning.

In specific installations and/or operation modes, some accessible parts of the burner outside the oven or duct may become hot. If required, precautions should be taken to prevent burning injuries by contact with hot surfaces.

## Start-up instructions

Instructions provided by the company or individual responsible for the manufacture and/or overall installation of a complete system incorporating MAXON burners take precedence over the installation and operating instructions provided by MAXON. If any of the instructions provided by MAXON are in conflict with local codes or regulations, please contact MAXON before initial start-up of equipment.



Read the combustion system manual carefully before initiating the start-up and adjustment procedure. Verify that all of the equipment associated with and necessary to the safe operation of the burner system has been installed correctly, that all pre-commissioning checks have been carried out successfully and that all safety related aspects of the installation are properly addressed.

Initial adjustment and light-off should be undertaken only by a trained commissioning engineer.

### Safety interlocks

---

Guarantee that all the required safety locks as described in the applicable local codes or regulations, or supplementary requested for safe operation of the overall installation, are working properly and resulting in a positive safety-lock of the burner. Do not bypass any of these safety interlocks. This will result in unsafe operation.

### Checks during and after start-up

---

During and after start-up, check the integrity of the system. Check all bolted connections after first firing (first time on temperature) and retighten if necessary.

### Purge

---

For safety reasons, it is required to purge the installation sufficiently long enough to ensure that all possible combustibles are evacuated before ignition. Refer to the applicable local codes and your specific application requirements to determine the purge time.

### Pilot ignition

---

Adjust pilot air flow and pilot gas regulator to correct set point before pilot ignition attempt. Turn adjustable orifice screw out (counter-clockwise) several turns from its fully seated position. Refine during lighting of the pilot to a yellow/blue flame and/or strongest stable flame signal. For FIG1 pilot endplates, note that pilot air may be adjusted for optimal pilot size and ignition by means of a shutter located between the cast iron pilot body and the stainless steel end enclosure plate.

### Main burner ignition

---

Adjust the main gas regulator at the correct set-point before igniting the main burner. Ensure that the gas-air ratio control valve is in the start position when lighting the main burner.

### Ratio adjustment

---

Once the main flame is ignited, adjust air/gas ratio of the burner to obtain the required combustion quality. Slowly increase capacity while observing the flame. Especially observe that the flame is well divided over the entire burner length, and going straight forward in the direction of the process air flow. Check that no damage is caused to duct walls or other equipment.

## Maintenance and inspection

### Safety requirements

---

Regular inspection, testing and recalibration of combustion equipment according to the installation manual is an integral part of its safety. Inspection activities and frequencies shall be carried out as specified in the installation manual.

Perform the following activities at least annually as part of a recommended preventative maintenance routine :

- Inspect burner internal parts for wear and oxidation.
- Inspect associated control instruments and devices for function with particular attention to all safety permissive switches.
- Perform leak tests on fuel shut-off valves according to any schedule established by the authority having jurisdiction.

### Visual inspections

---

Regular visual inspection of all connections (air and gas piping to the burner, bolting of the burner mounting flange, burner support in the duct) and burner flame shape and aspect are essential for safe operation.

### Recommended spare parts

---

**Keep local stock of spark ignitor and flame detector. It is not recommended to keep local stock of other burner parts. Consult the installation manual for burner system spare parts and accessories.**

Other available burner spare parts are:

- the mixing plate sets (mixing plate + screws and nuts + back-up bar)
- gas inlet gasket (gasket between gas inlet flange and burner body)
- end plate gasket (gasket between endplate and burner body)