

# Control valve S11T

## Pilot burners ZTA, ZT 40 and ZTI 55

Technical Information · GB

9 Edition 01.12



### Control valve S11T

- Independent of mains power supply due to thermo-electric safeguarding
- Available with contact switch for ignition with electrode
- Control valve S11T..R15 suitable for gas inlet pressures up to 1.5 bar

### Pilot burners ZTA, ZT 40 and ZTI 55

- Flame monitoring using a thermocouple, and in the case of ZTI 55 also using an ionization electrode
- Thermo pilot burners, optionally available with forced draught connection
- Electrical ignition with an electrode
- Save space due to their compact dimensions
- Different lengths make them suitable for individual installation situations

# Contents

Control valve S11T  
Pilot burners ZTA, ZT 40 and ZTI 55 . . . . . 1

Contents . . . . . 2

1 Application . . . . . 3

1.1 Control valve S11T . . . . . 3

1.2 Pilot burners . . . . . 3

1.3 Examples of application . . . . . 5

1.3.1 Thermo-electric safeguarding . . . . . 5

1.3.2 Thermo-electric safeguarding with electrical ignition via control valve . . . . . 5

2 Certification . . . . . 6

3 Function . . . . . 7

3.1 Control valve S11T . . . . . 7

3.2 Pilot burner . . . . . 7

3.2.1 ZTA . . . . . 7

3.2.2 ZT 40..A . . . . . 8

3.2.3 ZT 40../100 . . . . . 8

3.2.4 ZTI 55 . . . . . 8

4 Flow rate . . . . . 9

5 Selection . . . . . 10

5.1 Pilot burner capacity . . . . . 10

5.2 Selection table Control valve S11T . . . . . 10

5.3 Type code Control valve S11T . . . . . 10

5.4 Selection table Atmospheric pilot burner ZTA . . . . . 11

5.5 Type code Atmospheric pilot burner ZTA . . . . . 11

5.6 Selection table Pilot burner ZT 40 with protective tube, either atmospheric or with forced air supply . . . . . 11

5.7 Type code Pilot burner ZT 40 with protective tube, either atmospheric or with forced air supply . . . . . 11

5.8 Selection table Atmospheric pilot burner with ionization electrode ZTI 55 . . . . . 11

5.9 Type code Atmospheric pilot burner with ionization electrode ZTI 55 . . . . . 11

6 Project planning information . . . . . 12

6.1 Installation . . . . . 12

6.1.1 Control valve S11T . . . . . 12

6.1.2 Pilot burner . . . . . 12

6.2 Connecting to the gas train and the thermo-cable . . 13

6.2.1 S11T . . . . . 13

6.2.2 S11T..S . . . . . 13

7 Accessories . . . . . 14

7.1 Gas restrictor orifice, air restrictor orifice . . . . . 14

7.1.1 Gas restrictor orifice . . . . . 14

7.1.2 Air restrictor orifice . . . . . 14

7.2 High-voltage cable . . . . . 15

7.3 Thermo-cable and grounding cable . . . . . 15

7.4 Gas nozzle . . . . . 15

7.5 Ignition transformer . . . . . 15

8 Technical data . . . . . 16

8.1 Control valve S11T . . . . . 16

8.2 Pilot burner . . . . . 16

8.3 Dimensions . . . . . 17

8.3.1 S11T . . . . . 17

8.3.2 ZTA . . . . . 17

8.3.3 ZT 40..A . . . . . 18

8.3.4 ZT 40../100 . . . . . 18

8.3.5 ZTI 55 . . . . . 19

9 Maintenance cycles . . . . . 20

Feedback . . . . . 21

Contact . . . . . 21

## 1 Application

### 1.1 Control valve S11T



*Control valve S11T..S with switch to control an ignition transformer*

For thermo-electric safeguarding of gas-fired installations of any kind in conjunction with thermo pilot burners ZT.

The control valve S11T operates independently of mains power supply.

The control valve S11T..S is fitted with a switch to control an ignition transformer.

### 1.2 Pilot burners



*Pilot burner ZTA with grounding cable and thermo-cable, pilot burner ZT 40 with protective tube and air nozzle*

For safe ignition and thermo-electric safeguarding in conjunction with control valve S11T of atmospheric gas burners on furnaces in the metal, ceramics and non-ferrous metal industries, on heat treatment installations or in applications without voltage supply.

Suitable for operation with natural gas, town gas or LPG.

The pilot burners are ignited using an ignition electrode.

In the case of pilot burners ZTI 55, the flame is monitored via a thermocouple. An ionization electrode is also fitted, whose signal current may be used to release an additional valve, for example.



Wheel rim hardening installation



Annealing furnace



Intermittent shuttle kiln in the ceramics industry

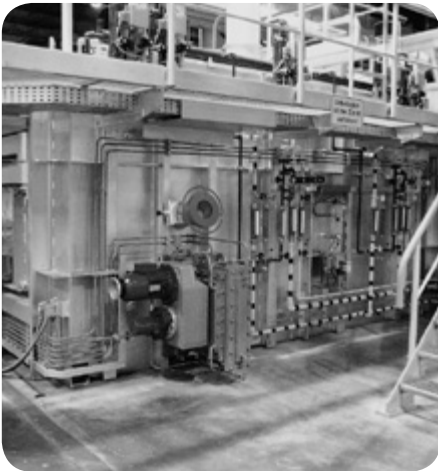

Pusher furnace

## 1.3 Examples of application

### 1.3.1 Thermo-electric safeguarding

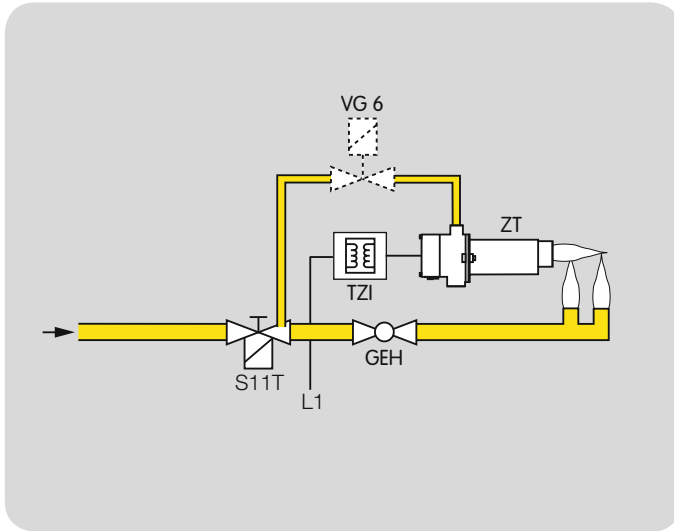

As soon as voltage is supplied to the ignition transformer, the pilot burner is ignited using an ignition spark. An additional gas solenoid valve VG 6 can be used as a safety valve, e.g. for overtemperature shut-down or power shortage cut-out.

### 1.3.2 Thermo-electric safeguarding with electrical ignition via control valve

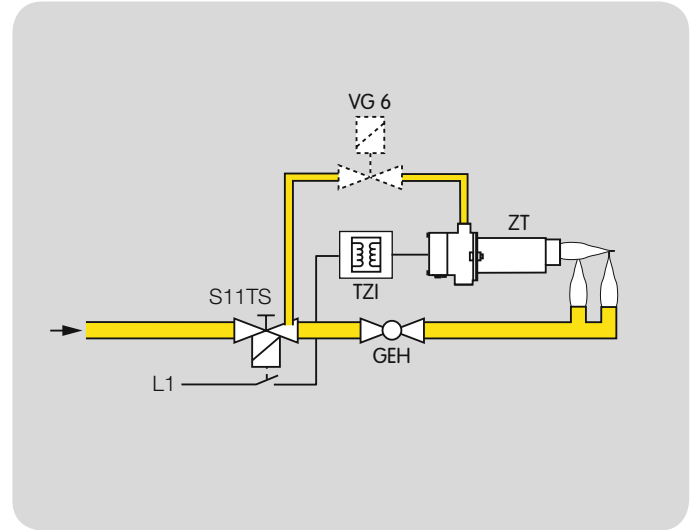

A contact is closed via the switch on the control valve S11TS so that voltage is supplied to the ignition transformer. The pilot burner is ignited using an ignition spark.

An additional gas solenoid valve VG 6 can be used as a safety valve, e.g. for overtemperature shut-down or power shortage cut-out.

## 2 Certification

S11T

EC type-tested and certified



pursuant to

- Gas Appliances Directive (90/396/EEC) in conjunction with EN 125

Meets the requirements of the

- Low Voltage Directive (2006/95/EC)

S11T, ZTA, ZT 40 and ZTI 55

Approval for Russia



Certified by Gosstandart pursuant to GOST-TR.

Approved by Rostekhnadzor (RTN).

## 3 Function

### 3.1 Control valve S11T

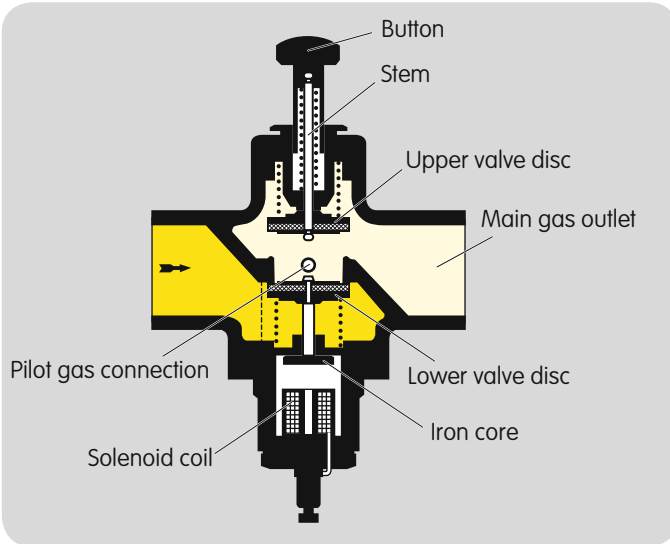

The upper valve disc closes off the gas outlet when the button is pressed all the way down. The stem pushes the lower valve disc down until the iron core rests on the solenoid coil. Gas can now flow to the pilot burner via the pilot gas connection. After the burner is ignited, the button is held down until thermo-electric voltage is applied to the solenoid coil, which attracts the iron core and thus holds the lower valve disc open.

As soon as the button is released, the upper valve disc opens the main gas outlet. The main gas can ignite.

If the thermo-electric voltage drops out, e.g. in the event of a flame failure, the iron core is no longer attracted. The pilot gas outlet and main gas outlet are closed by the lower valve disc.

### 3.2 Pilot burner

Gas flows from the gas connection to the burner head. Air from the surrounding atmosphere is inducted and is mixed with the combustion gas.

The gas/air mixture is ignited using an ignition electrode at the burner head. The flame heats the thermocouple. This produces a thermo-electric voltage on the thermocouple. A current flows via the thermo-cable to control valve S11T in order to keep this open.

In the event of flame failure, the thermocouple is no longer heated and the thermo-electric voltage drops out. The control valve closes.

#### 3.2.1 ZTA

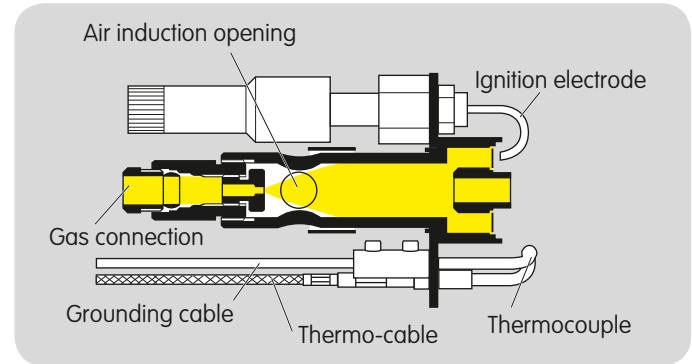

3.2.2 ZT 40..A

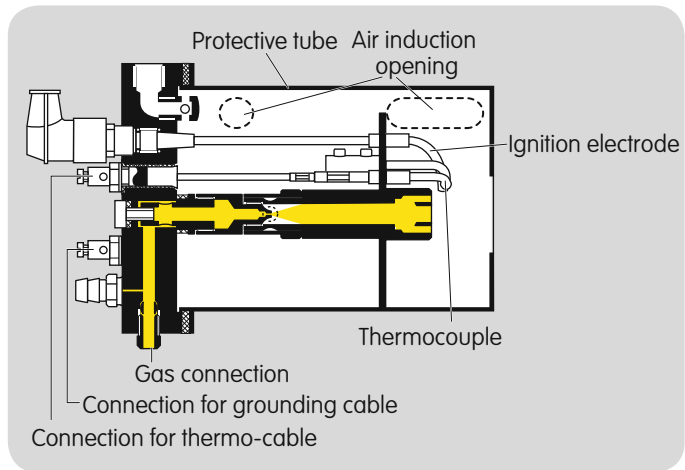

3.2.4 ZTI 55

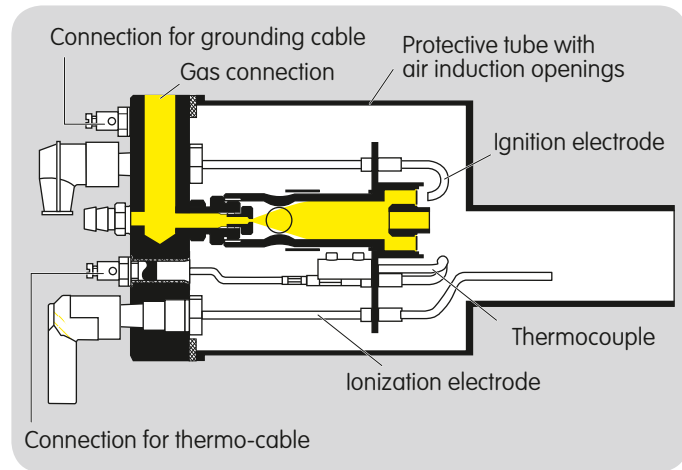

3.2.3 ZT 40../100

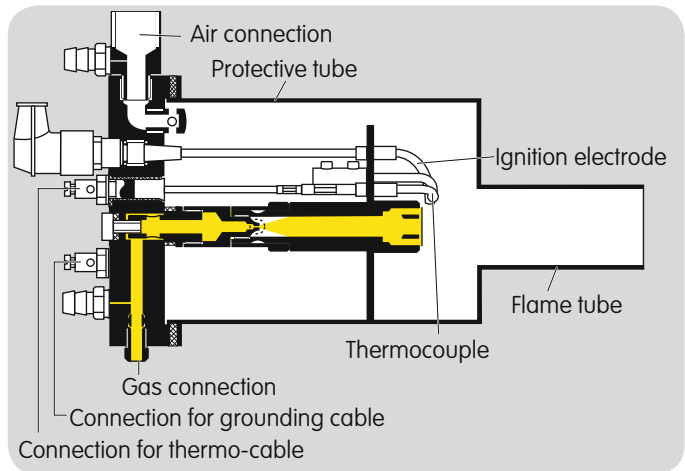



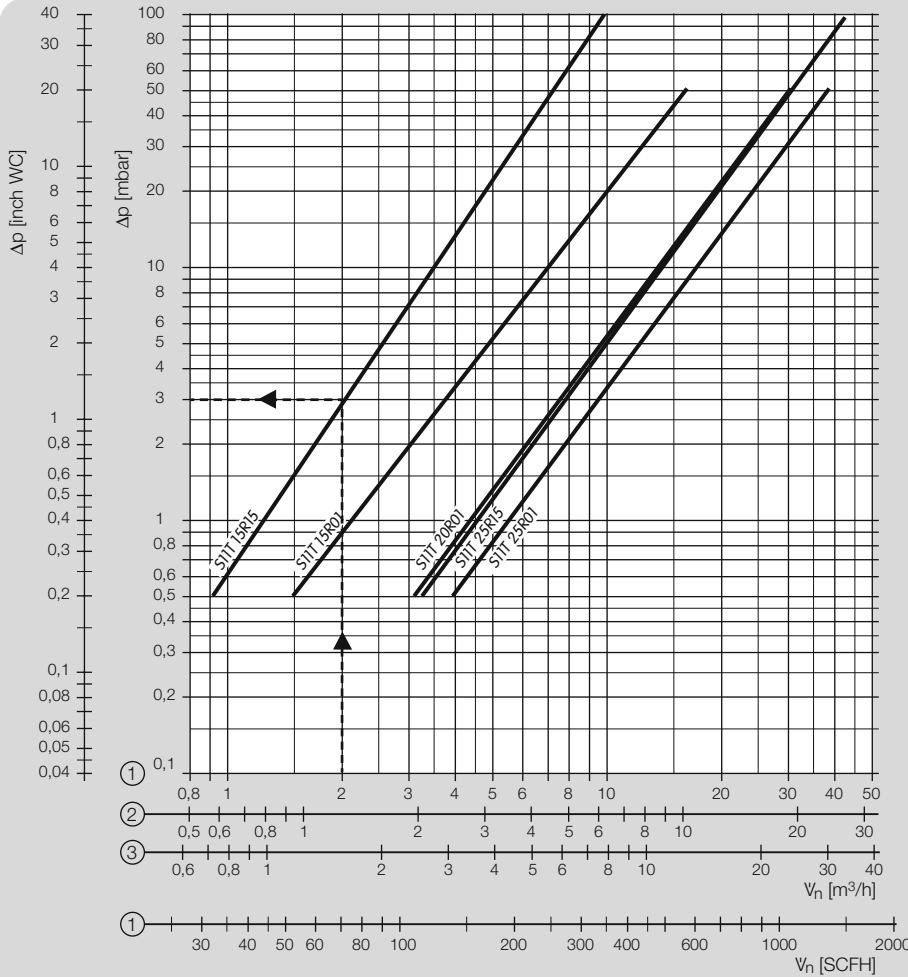

## 4 Flow rate

### S11T

When determining the pressure loss, operating cubic metres must be entered. Then the pressure loss  $\Delta p$  read must be multiplied by the absolute pressure in bar (positive pressure + 1) to account for the change in the medium's density.

Example:

inlet pressure  $p_0$   
 (positive pressure) = 1 bar,  
 gas type = natural gas,  
 operating flow rate  $V = 2 \text{ m}^3/\text{h}$ ,  
 $\Delta p$  in the diagram = 3 mbar,  
 $\Delta p = 3 \text{ mbar} \times (1 + 1) = 6 \text{ mbar}$   
 on S11T R15.

## 5 Selection

### 5.1 Pilot burner capacity

Burner	Operation with	Gas pressure [mbar]	P <sub>rated</sub> [kW]
ZTA	Natural gas	12–40*	1
	LPG	12–40*	1
	Town gas**	20–40*	1
ZT 40..A	Natural gas	20–35*	1
	LPG	40–60*	1
	Town gas	12–28*	1
ZT 40../100	Natural gas	20–40*	1
	LPG	40–60*	1
	Town gas	12–28*	1
ZTI 55	Natural gas	12–50	3.3
	LPG	12–50	2.5
	Town gas	20–60	2.3

\* In the case of higher gas pressures, fit a gas restrictor orifice.

\*\* Replace gas nozzle.

For pilot burners ZTA, a gas nozzle is installed at the factory for operation with natural gas or LPG. When using town gas, a gas nozzle has to be ordered separately for ZTA B, see page 15 (Gas nozzle).

### 5.2 Selection table Control valve S11T

	15	20	25	R	01	15	S*
S11T	●	●	●	●	●	●	○ <sup>1)</sup>

\* If "none", this specification is omitted.

<sup>1)</sup> S11T 20R15 and S11T 25R15 are not available with switch.

● = standard, ○ = available

#### Order example

S11T 25R15

### 5.3 Type code Control valve S11T

Code	Description
S11T	Control valve
	Nominal diameter
15	15
20	20
25	25
R	Rp internal thread
	Inlet pressure p <sub>U</sub>
01	max. 100 mbar
15	max. 1500 mbar
S	With switch

### 5.4 Selection table Atmospheric pilot burner ZTA

	B	G
ZTA	●	●

● = standard, ○ = available

**Order example**

ZTA G

### 5.5 Type code Atmospheric pilot burner ZTA

Code	Description
ZTA	Thermo pilot burner for control valve S11T
B	Natural gas
G	Propane/propane, butane/butane

### 5.6 Selection table Pilot burner ZT 40 with protective tube, either atmospheric or with forced air supply

	B	D	G	-200	/100*	A*
ZT 40	●	●	●	●	●	●

\* Available either as ZT 40../100 or as ZT 40..A.

● = standard, ○ = available

**Order example**

ZT 40B-200A

### 5.7 Type code Pilot burner ZT 40 with protective tube, either atmospheric or with forced air supply

Code	Description
ZT 40	Thermo pilot burner with protective tube
B	Natural gas
D	Town gas
G	LPG
-200	Protective tube length [mm]
/100*	Protective tube length [mm]
A*	Atmospheric

\* Available either with flame tube and air line connection or as an atmospheric burner.

### 5.8 Selection table Atmospheric pilot burner with ionization electrode ZTI 55

	B	G	-105	/120	A
ZTI 55	●	●	●	●	●

● = standard, ○ = available

**Order example**

ZTI 55B-105/120A

### 5.9 Type code Atmospheric pilot burner with ionization electrode ZTI 55

Code	Description
ZTI 55	Thermo pilot burner with ionization electrode
B	Natural gas
G	LPG
D	Coke oven gas, town gas
105	Protective tube length [mm]
/120	Protective tube length [mm]
A	Atmospheric

## 6 Project planning information

### 6.1 Installation

#### 6.1.1 Control valve S11T

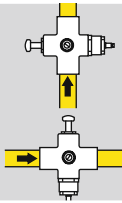

Installation position: the button for activating the valve must point upwards or to the side. It must not point downwards.

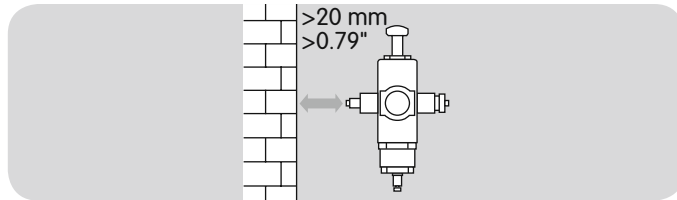

The control valve must not be in contact with masonry. Minimum clearance 20 mm.

#### 6.1.2 Pilot burner

ZT 40, ZTI 55 installation position: horizontal or vertical, when installing in the vertical position, the burner head must be facing upwards.

ZTA installation position: vertical or horizontal, when installing in the horizontal position, the thermocouple must be facing upwards; when installing in the vertical position, the burner head must be facing upwards.

Ensure that the pilot burner is not thermally overheated and that air flow to the atmospheric burners ZTA, ZT 40..A and ZTI 55 via the air induction openings is sufficient.

For ZT 40../100, we recommend installing an adjusting cock GEH 8 in the air line upstream of the burner for adjusting the required air pressure.

For higher gas and air pressures and an optimal gas and air pressure ratio, gas and air restrictor orifices are available, see page 14 (Accessories)

Install the pilot burner so that the thermocouple is not in contact with the main burner flame.

Pilot burner ZTA is fitted with thermo-cables to transfer the thermo-electric voltage to the control valve.

## 6.2 Connecting to the gas train and the thermo-cable

Use an 8 × 1 tube as pilot gas line from the control valve to the pilot burner. A solenoid valve VG 6 can be used as an additional safety valve, e.g. for overtemperature shut-down or power shortage cut-out.

Use copper cable with a suitable cross-section for transferring the thermo-electric voltage and for grounding, see page 15 (Thermo-cable and grounding cable).

Cable length	Cable cross-section	Cable diameter
2–3 m	6 mm <sup>2</sup>	2.9 mm

The ZTA is supplied with a fitted thermo-cable and grounding cable.

**M** = grounding cable connection,

**T** = thermocable connection.

### 6.2.1 S11T

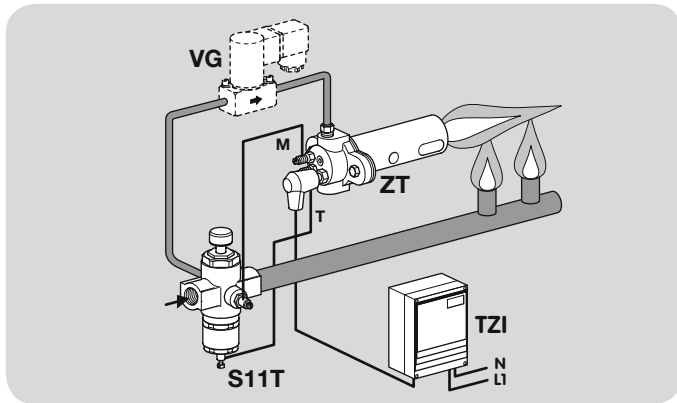

### 6.2.2 S11T..S

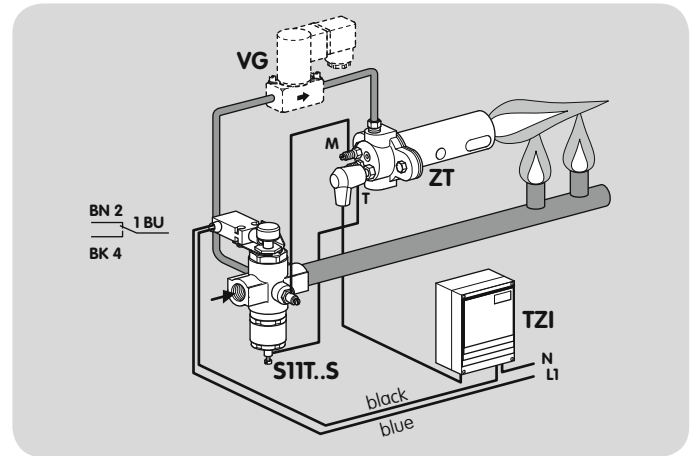

## 7 Accessories

### 7.1 Gas restrictor orifice, air restrictor orifice

For adjusting the gas or air volume to increased supply pressures, a gas or air restrictor orifice is to be installed upstream of the burner.

#### 7.1.1 Gas restrictor orifice

##### For ZTA

With internal thread: M12 x1 (for 8 x1 tube).

Hole [mm]	For gas pressures for operation with			Order No.
	natural gas [mbar]	propane [mbar]	town gas [mbar]	
1.1	–	–	40–60	74451461
0.8	–	–	60–100	74451462
0.65	4–120	–	100–300	74451466
0.47	120–300	40–120	300–900	74451469
0.36	300–700	120–300	900–1500	74451471
0.31	700–1500	–	–	74451472
0.27	–	300–700	–	74451474
0.24	–	700–1500	–	74451475

#### For ZT 40

With internal thread: M12 x1 (for 8 x1 tube).

Hole [mm]	For gas pressures for operation with			Order No.
	natural gas [mbar]	propane [mbar]	town gas [mbar]	
1.1	–	–	28–70	74451461
0.8	–	–	70–160	74451462
0.65	40–120	60–80	160–420	74451466
0.47	120–350	80–160	420–1500	74451469
0.36	350–1000	160–300	–	74451471
0.31	1000–1500	300–500	–	74451472
0.27	–	500–800	–	74451474
0.24	–	800–1200	–	74451475
0.21	–	1200–1500	–	74451476

#### 7.1.2 Air restrictor orifice

##### For ZT 40../100

We recommend installing an adjusting cock GEH 8 for adjusting the required air pressure. For air supply pressures > 800 mbar, we also recommend installing an air restrictor orifice upstream of the adjusting cock.

With Rp 1/4" connecting thread, 1.5 mm hole.

The pressure loss of the orifice is 700 mbar at 1.5 m<sup>3</sup>/h of air.

Order No. 74452742

## 7.2 High-voltage cable

For ignition cable.

FZLSi 1/7, -50 to 180°C (-58 to 356°F),

Order No. 04250410, or

FZLK 1/7, -5 to 80°C (23 to 176°F),

Order No. 04250409.

## 7.3 Thermo-cable and grounding cable

For transferring the thermo-electric voltage from the thermocouple of burners ZT 40 and ZTI 55 to the thermo-cable connection of the control valve S11T and for grounding.

Cable cross-section 6 mm<sup>2</sup>,

Order No. 04250404

## 7.4 Gas nozzle

For ZTA B for operation with town gas, diameter = 1.1 mm.

Order No. 75457938

## 7.5 Ignition transformer

When using the control valve S11T..S for electrical ignition.

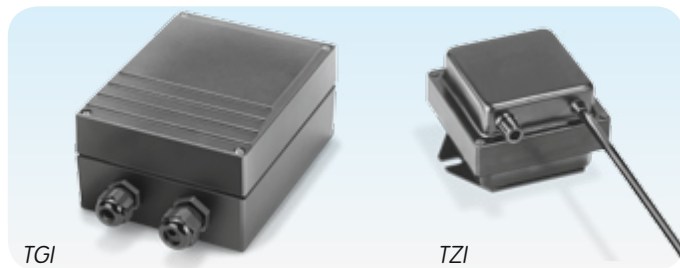

E.g. TGI 7.5-12/100 or TZI 7.5-12/100.

High voltage:  $\geq 7.5$  kV, output current: 12 mA at 50 Hz (9 mA at 60 Hz).

## 8 Technical data

### 8.1 Control valve S11T

Gas types: natural gas, town gas or LPG.

Pilot gas connection: for 8 x 1 tube.

Opening time: 10 – 15 s.

Closing time (decrease of thermo-electric voltage + valve closing time): < 30 s.

Ambient temperature: -20 to +60°C.

Thermo-electric voltage:  
extinction voltage: 8 mV.

Max. inlet pressure  $p_U$ :  
S11T..01 = 100 mbar,  
S11T..15 = 1.5 bar.

### 8.2 Pilot burner

Burner	Operation with	Gas pressure [mbar]	Prated [kW]
ZTA B	Natural gas	12 – 40*	1
ZTA G	LPG	12 – 40*	1
ZTA B	Town gas**	20 – 40*	1
ZT 40B..A	Natural gas	20 – 35*	1
ZT 40G..A	LPG	40 – 60*	1
ZT 40D..A	Town gas	12 – 28*	1
ZT 40B../100	Natural gas	20 – 40*	1
ZT 40G../100	LPG	40 – 60*	1
ZT 40D../100	Town gas	12 – 28*	1
ZTI 55B	Natural gas	12 – 50	3.3
ZTI 55G	LPG	12 – 50	2.5
ZTI 55D	Town gas	20 – 60	2.3

\* In the case of higher gas pressures, fit a gas restrictor orifice, see page 14 (Gas restrictor orifice).

\*\* For this, the gas nozzle must be replaced, see page 15 (Gas nozzle).

Gas connection: compression fitting for tube  $d = 8$  mm.

Thermo-electric voltage:

under load: 10 – 15 mV,

in idle state: 20 – 25 mV.

Extinction voltage: < 8 mV.



## 8.3 Dimensions

### 8.3.1 S11T

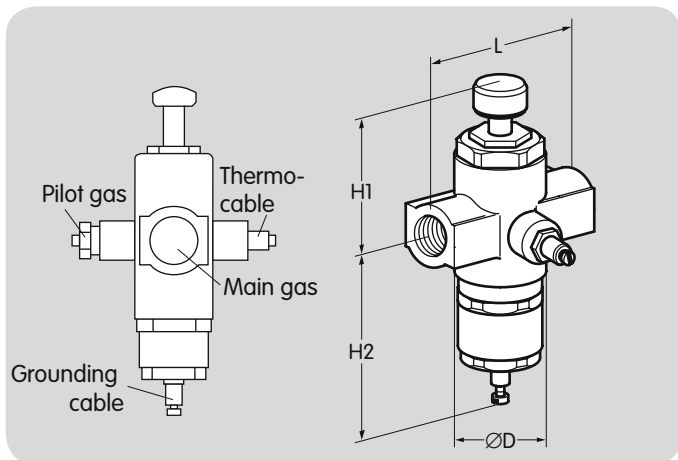

Connection		Dimensions					$p_{U \text{ max.}}$	Weight
Main gas	Pilot gas	L	$\varnothing D$	H1	H2			
DN	Rp		mm	mm	mm	mm	mbar	kg
15	1/2	8 x 1	75	42	55	75	100	0.9
15	1/2	8 x 1	75	42	55	75	1500	1.1
20	3/4	8 x 1	90	50	60	80	100	1.1
25	1	8 x 1	110	56	70	85	100	1.3
25	1	8 x 1	110	56	110	88	1500	1.7

### 8.3.2 ZTA

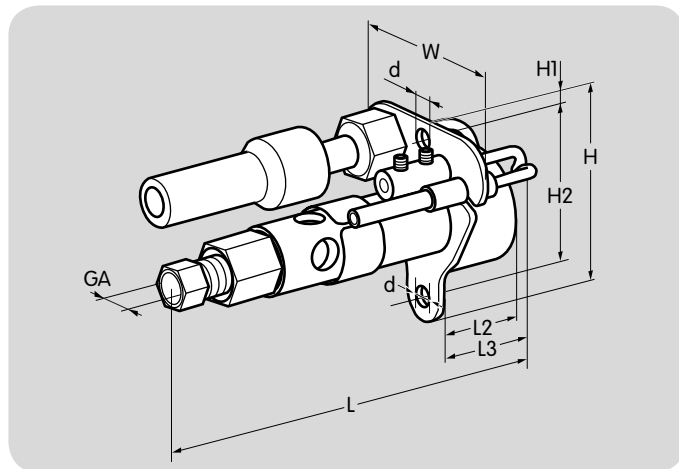

Connection	Dimensions								Weight
	L	L2	L3	d	W	H	H1	H2	kg
GA	mm	mm	mm	mm	mm	mm	mm	mm	
8 x 1	116	20	27	6.1	54	58	7	46	0.33

### 8.3.3 ZT 40..A

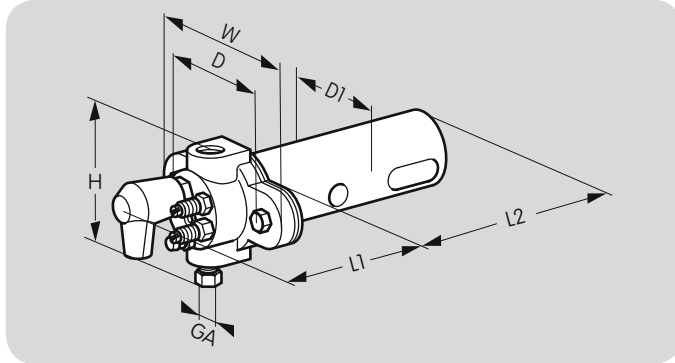

Connections Gas GA	Dimensions [mm]								Weight kg
	L1	L2	L3	D1	D2	D	W	H	
8×1	70	100	–	40	–	72	95	60	0.5
8×1	70	150	–	40	–	72	95	60	0.6
8×1	70	200	–	40	–	72	95	60	0.7
8×1	70	300	–	40	–	72	95	60	0.8
8×1	70	400	–	40	–	72	95	60	1.0
8×1	70	500	–	40	–	72	95	60	1.1

Other burner lengths on request.

### 8.3.4 ZT 40../100

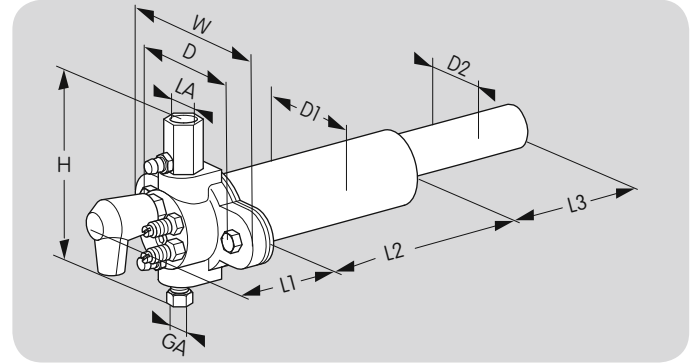

Connections Gas GA	Air LA	Dimensions [mm]								Weight kg
		L1	L2	L3	D1	D2	D	W	H	
8×1	Rp 1/4	70	100	100	40	24	72	95	60	0.6
8×1	Rp 1/4	70	150	100	40	24	72	95	60	0.7
8×1	Rp 1/4	70	200	100	40	24	72	95	60	0.8
8×1	Rp 1/4	70	300	100	40	24	72	95	60	0.9
8×1	Rp 1/4	70	400	100	40	24	72	95	60	1.1
8×1	Rp 1/4	70	500	100	40	24	72	95	60	1.2

Other burner lengths on request.

8.3.5 ZTI 55

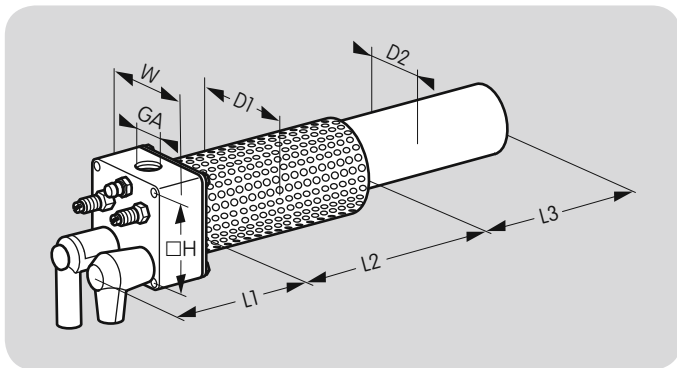

Connections	Dimensions [mm]							Weight kg
	L1	L2	L3	D1	D2	W	H	
Gas GA Rp ¼	70	105	120	55	37	59	45	0.82

## 9 Maintenance cycles

The system requires little servicing. Check the safety time of S11T/S11T..S once a year.

## Feedback

Finally, we are offering you the opportunity to assess this “Technical Information (TI)” and to give us your opinion, so that we can improve our documents further and suit them to your needs.

### Clarity

Found information quickly  
Searched for a long time  
Didn't find information  
What is missing?  
No answer

### Comprehension

Coherent  
Too complicated  
No answer

### Scope

Too little  
Sufficient  
Too wide  
No answer



### Use

To get to know the product  
To choose a product  
Planning  
To look for information

### Navigation

I can find my way around  
I got “lost”  
No answer

### My scope of functions

Technical department  
Sales  
No answer

## Remarks

(Adobe Reader 7 or higher required)  
[www.adobe.com](http://www.adobe.com)

## Contact

Elster GmbH  
Postfach 2809 · 49018 Osnabrück  
Strothweg 1 · 49504 Lotte (Büren)  
Germany  
T +49 541 1214-0  
F +49 541 1214-370  
[info@kromschroeder.com](mailto:info@kromschroeder.com)  
[www.kromschroeder.com](http://www.kromschroeder.com)

The current addresses of our international agents are available on the Internet:  
[www.kromschroeder.de/index.php?id=718&L=1](http://www.kromschroeder.de/index.php?id=718&L=1)

We reserve the right to make technical modifications in the interests of progress.  
Copyright © 2013 Elster GmbH  
All rights reserved.

