

# R7140G,L,M Burner Control Modules

## INSTALLATION INSTRUCTIONS



## APPLICATION

The Honeywell R7140G,L,M Burner Control Modules are microprocessor-based integrated burner controls for automatically fired gas, oil or combination fuel single burner applications. The Burner Control Module system consists of a Relay Module, Q520A Subbase, Amplifier and Purge Card. Options include S7800 Keyboard Display Modules (KDM).

The R7140 Burner Control Modules directly replace many BC7000 PM720G,L,M, and many R4150G,L,M and R4140G,L,M units using the existing Q520A 20-terminal Wiring Subbase.

The R7140 can be demonstrated or tested on the FSP5004 tester. Note that the R7849 UV Amplifier or the R7851 Optical Flame Amplifier cannot be tested.

The R7140G,L,M is programmed to provide a level of safety, functional capability and features beyond the capacity of conventional controls.

Functions provided by the R7140G,L,M include automatic burner sequencing, flame supervision, system status indication, system or self-diagnostics and troubleshooting.

## FEATURES

- Device status available to ModBus™ through S7810M card or S7800A1001 Series 5 Keyboard Display.
  - Safety features:
    - Interlock check.
    - Closed loop logic test.
    - Dynamic AMPLI-CHECK™.
    - Dynamic input check.
    - Dynamic safety relay test.
    - Dynamic self-check logic.
    - Expanded safe-start check.
    - High Fire Purge Switch test (R7140L only).
    - Internal hardware status monitoring.
    - Low Fire Start Switch test.
    - Tamper resistant timing and logic.
  - Application flexibility.
  - 0.8 or 3.0 second Flame Failure Response Time (FFRT), depending on amplifier selected.
  - Dependable, long-term operation provided by microcomputer technology.
  - Five LEDs for sequence information. See Fig. 1.
  - Five function Run/Test Switch.
  - Interchangeable plug-in flame amplifiers.
  - Nonvolatile memory; history files and sequencing status are retained after loss of power and can be viewed using the Keyboard Display Module S7800A1001 (sold separately).
  - Report generation (optional) through modbus™.
- NOTE:** Check Service Notes on page 7 and Static Check-out on page 26 prior to installation of R7140.
- Burner controller data (optional):
    - Lockout/alarm status.
    - Total cycles of operation.
    - Total hours of operation.
  - Status of configuration jumpers.
  - Status of Run/Test Switch.



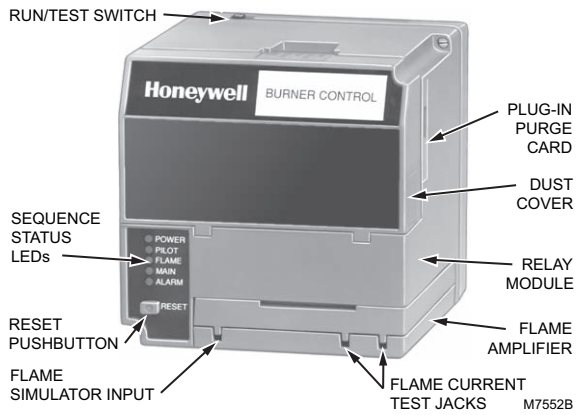

Fig. 1. Burner Control Module and sequence status LEDs.

## SPECIFICATIONS

### Electrical Ratings (See Table 1):

Voltage and Frequency: 120 Vac (+10%/-15%), 50 or 60 Hz (±10%).

Power Dissipation in the Run Mode: 10W maximum.  
 Maximum Total Connected Load: 2000VA.  
 Fusing—Total Connected Load: 15A fast blow, type SC or equivalent.

### Environmental Ratings:

Ambient Temperature:

Operating: -40°F to +140°F (-40°C to +60°C).

Storage: -40°F to +150°F (-40°C to +66°C).

Humidity: 85% relative humidity, continuous, noncondensing.  
 Vibration: 0.5G environment.

### Weight:

With Dust Cover and Q520A Subbase: 4 lb., 5 oz. (1.96 kg).

### Dimensions:

See Fig. 2.

### Approvals:

Underwriters Laboratories Inc. UL, cULus Component Recognized.

Federal Communications Commission: Part 15, Class A—Emissions.

### Mounting:

Q520A 20-terminal Subbase for panel mounting.

### Required Components:

Plug-in Flame Signal Amplifier. See Table 1.

Plug-in Purge Timer Cards. See Table 2.

Table 1. Flame Detection Systems.

Plug-in Flame Signal Amplifiers				Applicable Flame Detectors			
Type	Color	Self-Checking	Model	Flame Failure Response Time (sec) <sup>a</sup>	Fuel	Type	Models
Rectification	Green	Dynamic Self-Check	R7824C <sup>b,c,h</sup>	3	Gas, oil, coal	Ultraviolet (Purple Peeper®)	C7024E,F
		No	R7847A <sup>g</sup>	0.8/1 or 2/3	Gas	Rectifying Flame Rod Holders <sup>i</sup>	C7004, C7007, C7011 Complete Assemblies: C7008, C7009, Q179
		No	R7847A <sup>g</sup>	2/3	Gas, oil, coal	Ultraviolet (Purple Peeper®)	C7012A,C.
		Dynamic Ampli-Check®	R7847B <sup>d,g</sup>	0.8/1 or 2/3	Gas	Rectifying Flame Rod Holders <sup>i</sup>	C7004, C7007, C7011 Complete Assemblies: C7008, C7009, Q179
		Dynamic Ampli-Check®	R7847B <sup>d,g</sup>	2/3	Gas, oil, coal	Ultraviolet (Purple Peeper®)	C7012A,C
		Dynamic Self-Check	R7847C <sup>c,h</sup>	3	Gas, oil, coal	Ultraviolet (Purple Peeper®)	C7012E,F
Infrared	Red	No	R7848A	2/3	Gas, oil, coal	Infrared (Lead Sulfide)	C7015
		Dynamic Ampli-Check®	R7848B <sup>d</sup>	2/3	Gas, oil, coal	Infrared (Lead Sulfide)	C7015
	Red/White	No	R7852A	2/3	Gas, oil, coal	Infrared (Lead Sulfide)	C7915
		Dynamic Ampli-Check®	R7852B <sup>b</sup>	2/3	Gas, oil, coal	Infrared (Lead Sulfide)	C7915
Ultraviolet	Purple	No	R7849A	0.8/1 or 2/3	Gas, oil	Ultraviolet (Minipeeper)	C7027, C7035, C7044 <sup>f</sup>
		Dynamic Ampli-Check®	R7849B <sup>d</sup>	0.8/1 or 2/3	Gas, oil	Ultraviolet (Minipeeper)	C7027, C7035, C7044 <sup>f</sup>
		Dynamic Self-Check	R7861A <sup>c,e</sup>	0.8/1 or 2/3	Gas, oil, coal	Ultraviolet	C7061
	Blue	Dynamic Self-Check	R7886A <sup>c,e</sup>	2/3	Gas, oil, coal	Ultraviolet (Adjustable Sensitivity)	C7076
Optical	White	Dynamic Ampli-Check®	R7851B	0.8/1 or 2/3	Gas, oil, coal	Optical (UV, Visible Light)	C7927, C7962
		Dynamic Self-Check	R7851C <sup>c</sup>	2/3	Gas, oil, coal	Optical (UV only)	C7961

<sup>a</sup> Flame Failure Response Time (FFRT) depends on selection of amplifier and 7800 SERIES and R7140 Relay Module.

<sup>b</sup> R7824C is used only with the 24 Vdc RM7824 Relay Module and C7024E,F Flame Detectors.

<sup>c</sup> Circuitry tests all electronic components in flame detection system (amplifier and detector) 12 times a minute during burner operation and shuts down burner if detection system fails.

<sup>d</sup> Circuitry tests flame signal amplifier 12 times a minute during burner operation and shuts down burner if amplifier fails.

<sup>e</sup> 200/220/240 Vac applications require a 120 Vac, 10 VA minimum stepdown transformer (not provided) to drive the shutter. Applies to R7886A series 2 or greater; R7861 series 1 or greater. Fig. 2 shows flame detector wiring.

<sup>f</sup> Use C7027, C7035 and C7044 Flame Detectors only on burners that cycle on-off at least once every twenty-four hours. Use C7061A Ultraviolet Detector with R7861A Amplifier or C7076A Flame Detector with R7886A Amplifier as ultraviolet flame detection system for appliances with burners that remain on continuously for twenty-four hours or longer.

<sup>g</sup> R7847A,B Amplifiers with 0.8/1 second FFRT should **NOT** be used with C7012A,C Solid State Ultraviolet Detectors.

<sup>h</sup> R7824C Series 2 and greater and R7847C Series 4 or greater, check flame detector system when flame reaches 1.5 Vdc or at 4.5 seconds, whichever occurs first.

NOTE: R7824C Series 2 or greater and R7847C Series 4 or greater, pulse the shutter when signal of 1.5 Vdc is sensed. Display readings of 0.7 to 2.4 Vdc are common.

<sup>i</sup> Order flame rod separately; see flame detector Instructions for holder.

**Table 2. Plug-in Purge Timer Cards.**

Pre-Purge Timing	Product Number
7	ST7800A1013
30	ST7800A1039
40	ST7800A1047
60	ST7800A1054
90	ST7800A1062

Above times cover the Purge timings of the R4140/50 Programmers and PM720.

Other timings exist—consult the Tradeline catalog for complete list of ST7800 Purge timers.

**Accessories:**

The following accessories enhance the R7140 Burner Control Module and are available through local 7800 SERIES distributors.

**Keyboard Display Modules (KDM):**

- S7800A1001 English language.
- S7800A1035 French language.
- S7800A1043 German language.
- S7800A1050 Italian language.

- S7800A1068 Spanish language.
- S7800A1118 Katakana (Japanese) language.
- S7800A1126 Portuguese language.
- S7800A1142 English language.

**Communications:**

S7810A1009 Data ControlBus Module™ (if no KDM is used).

S7810M1003 ModBus™ Module.

**Miscellaneous:**

S7820A1007 Remote Reset Module.

S7830A1005 Expanded Annunciator, 120 Vac, 50/60 Hz.

203541 Data ControlBus Connector, 5-wire.

203765 Remote Display Mounting Bracket.

221729 Dust cover, Relay Module.

50023821-001 Keyboard Display Module Cover, NEMA 4, clear.

50023821-002 Keyboard Display Module Cover, NEMA 4, clear with reset button.

205321 Flush Display mounting kit.

221818A Extension Cable, display, 5 ft. (1524 mm).

221818C Extension Cable, display, 10 ft. (3048 mm).

FSP5004 Tester.

123514A Rectification Flame Simulator.

203659 Ultraviolet Flame Simulator.

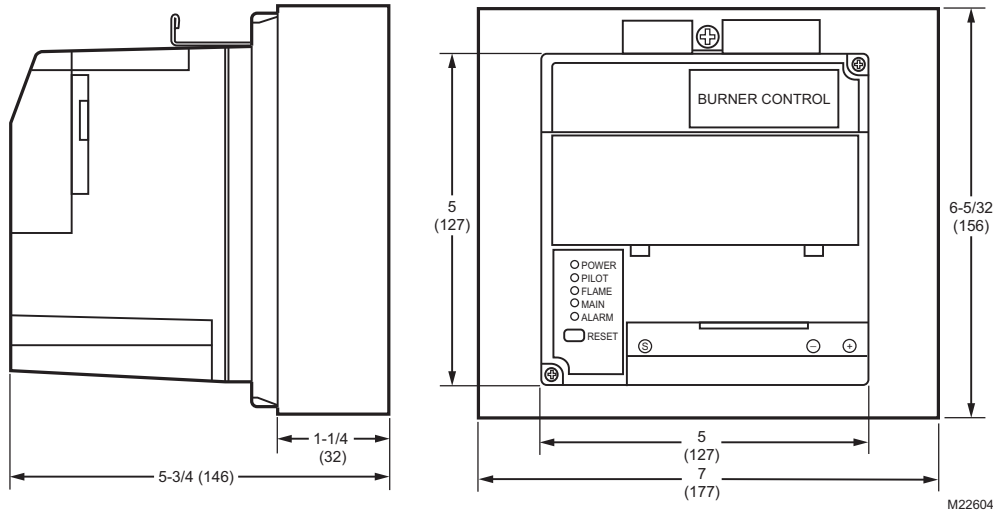

**Fig. 2. Mounting dimensions of R7140G,L,M Burner Control Module with Q520A Subbase, in in. (mm).**

**Table 3. Terminal Ratings.**

Terminal No.	Description	Ratings
G	Flame Sensor Earth Ground <sup>a</sup>	—
Earth G	Earth Ground <sup>a</sup>	—
L2(N)	Line Voltage Common	—
L1	Line Voltage Supply (L1)	120 Vac (+10/-15%), 50 or 60 Hz (±10%).
3	Lockout/Running Interlock	120 Vac, 8A run, 43A inrush.
4	Pre-Ignition Interlock Input	120 Vac, 1 mA.
5	Pilot Valve/Ignition	120 Vac. See Table 4.
6	Interrupted/Intermittent Pilot Valve/First Stage Oil Valve	120 Vac. See Table 4.
7	Main Fuel Valve	120 Vac. See Table 4.
8	Burner Motor	120 Vac, 9.8 AFL, 58.8 ALR (inrush).
9	Alarm	120 Vac, 1A pilot duty.
10	Firing Rate High Fire	120 Vac, 75 VA pilot duty.
11	Firing Rate Common	120 Vac, 75 VA pilot duty.
12	Firing Rate Modulate	120 Vac, 75 VA pilot duty.
13	Low Fire Switch Input	120 Vac, 1 mA.
14	Firing Rate Low Fire	120 Vac, 75 VA pilot duty.
15	High Fire Switch Input	120 Vac, 1 mA.
16	Burner Controller and Limits	120 Vac, 1 mA.
17	Shutter	120 Vac, 0.5A.
18	Ignition	120 Vac, 4.5A ignition.
F	Flame Sensor	60 to 220 Vac, current limited.

<sup>a</sup> The R7140 must have an earth ground providing a connection between the subbase and the control panel or the equipment. The earth ground wire must be capable of conducting the current to blow the 15A fast blow fuse (or breaker) in the event of an internal short circuit. The R7140 needs a low impedance ground connection to the equipment frame, which, in turn, needs a low impedance connection to earth ground.

**Table 4. Terminal Ratings.**

Terminal	Typical Load	Maximum Rating at 120 Vac, 60 Hz
5 or 6	Ignition Transformer/Pilot Valve/First Stage Fuel Valve	4.5A ignition and 50 VA pilot duty, or 2.5A ignition and 75 VA pilot duty.
7	Main Fuel Valve(s) (solenoid/motorized/diaphragm) and Vent Valve, if required	250 VA pilot duty or 65 VA pilot duty in parallel with motorized valve(s) using a total of 1150 VA locked rotor (inrush), 460 VA to open, and 250 VA to hold or motorized valve(s) using a total of 1500 VA locked rotor (inrush), 600 VA to open, and 250 VA to hold.

**Table 5. Sequence Timing for Normal Operation.**

Device	Initiate	Standby	Purge	Flame Establishing Period		Run	Post Purge Timing	Interlock Circuits	Firing Rate Circuit	Energy Saving Pre-Purge	Approval Code Bodies
				Pilot	Main						
R7140G	10 sec.	*	**	4 or 10 sec.	10, 15 sec. <sup>a</sup> or intermittent.	*	15 sec.	Pre-Ignition, Running, Low Fire	4-wire modulating	No	UL/CSA Modulating
R7140L			10 or 15 sec. <sup>a</sup>		Pre-Ignition, Lockout High and Low Fire			FM/IRI Modulating			
R7140M			10 sec. or intermittent		Pre-Ignition, Running, isolated Low Fire.			UL/CSA On-Off.			

<sup>a</sup> 30 seconds with JR2 clipped and jumper from terminal 8 to terminal 15.

\* STANDBY and RUN can be an infinite time period.

\*\* PURGE will be determined by which ST7800A purge card is selected; 15 timings are available from 2 seconds to 30 minutes.

**NOTE: Allowable inrush can be up to ten times the pilot duty rating.**

EXAMPLE: Pilot duty rating = 50 VA.

At 120 V, running current is:

$$50/120 = 0.42A.$$

Maximum allowable inrush is ten times 0.42A = 4.2A.

**IMPORTANT**

1. Wiring connections for the relay modules are unique; therefore, refer to Fig. 4–11 or the correct Specifications for proper subbase wiring, and sequence charts.
2. Wiring must comply with all applicable codes, ordinances and regulations.
3. Wiring must comply with NEC Class 1 (Line Voltage) wiring.
4. Loads connected to the R7140 must not exceed those listed in the Specifications; see Table 3 and 4.
5. Limits and interlocks must be rated to simultaneously carry and break current to the ignition transformer, pilot valve, and main fuel valve(s).
6. All external timers must be listed or component recognized by authorities who have jurisdiction for the specific purpose for which they are used.
7. For on-off gas-fired systems, some authorities who have jurisdiction prohibit the wiring of any limit or operating contacts in series between the flame safeguard control and the main fuel valve(s).
8. Two Flame Detectors can be connected in parallel with the exception of flame detectors C7927, C7915, C7961, and C7962.
9. This equipment generates, uses and can radiate radio frequency energy and, if not installed and used in accordance with the instructions, may cause interference to radio communications. It has been tested and found to comply with the limits for a Class A computing device of Part 15 of FCC rules which are designed to provide reasonable protection against such interference when operated in a commercial environment. Operation of this equipment in a residential area may cause interference; in which case, the users at their own expense may be required to take whatever measures are required to correct this interference.
10. This digital apparatus does not exceed the Class A limits for radio noise for digital apparatus set out in the Radio Interference Regulations of the Canadian Department of Communications.

## INSTALLATION

### When Installing this Product...

1. Read these instructions carefully. Failure to follow them could damage the product or cause a hazardous condition.
2. Check the ratings given in the instructions and marked on the product to make sure the product is suitable for the application.
3. Installer must be a trained, experienced, flame safeguard service technician.
4. After installation is complete, check out the product operation as provided in these instructions.

### WARNING

**Fire or Explosion Hazard.**

**Can cause property damage, severe injury, or death.**

To prevent possible hazardous burner operation, verify safety requirements each time a control is installed on a burner.

### WARNING

**Electrical Shock Hazard.**

**Can cause serious injury or death.**

Disconnect the power supply before beginning installation. More than one power supply disconnect may be required.

## Location

### Humidity

Install the relay module where the relative humidity never reaches the saturation point. The relay module is designed to operate in a maximum 85 percent relative humidity continuous, noncondensing moisture environment. Condensing moisture may cause a safety shutdown.

### Vibration

Do not install the relay module where it could be subjected to vibration in excess of 0.5G continuous maximum vibration.

### Weather

The relay module is not designed to be weathertight. When installed outdoors, protect the relay module using an approved weathertight enclosure.

## Final Wiring Check

1. Check the power supply circuit. The voltage and frequency tolerance must match those of the R7140. A separate power supply circuit may be required for the R7140. Add the required disconnect means and overload protection.
2. Check all wiring circuits and complete the Static Checkout, Table 8, before installing the R7140 on the subbase.
3. Install all electrical connectors.
4. Restore power to the panel.

### Service Notes:

Per industry standards, a conduit seal or a cable type that is sealed is required to be installed in a device that can result in flammable gas or flammable liquid flow through a conduit or cable to an electrical ignition source in the event of a seal leakage or diaphragm failure. This could be on the gas valves, or gas or oil pressure regulators.

Check the Q520 Wiring Subbase terminals against the typical wiring drawings, Figures 7, 8, 12, 13, 17, or 18.

If wires are attached to terminals that are unused in the figures, **DO NOT INSTALL THE R7140** until you have identified the connections' functions. Most likely the old subbase terminals were used as tie points, so removing the wires, capping with a wire nut, and tucking the wire down into the subbase is all that needs to be done.

Make sure the wiring subbase of the old device is a 20-terminal Q520 (four rows of 5 terminals).

Make sure the system Controller is connected to the correct terminal on the Q520 wiring subbase. It may be in a wire nut tucked into the subbase. It needs to be connected to a terminal (like terminal 4 or 16).

Make sure there is an electrical service ground wire connection to the G terminal in the wiring subbase.

R4140G or BC7000 with PM720G replacement.

- If the application was a dual burner ignition, check the Q520 subbase for a jumper between terminals 6 to 7, discard the jumper and move the main valve connection (terminal 7) to terminal 6.

Replacing GP201 or GP301 devices:

- High Fire (or Purge Rate) Switch may be connected to terminal D.
- Identify, remove, and connect to terminal M.

Replacing GP101 devices:

- Check wiring subbase. If D is jumpered to 8, remove the jumper.

Replacing R4140 programmers on Carlin 1050 and 1150 burners:

- Remove jumper from 6 to 7.
- Remove jumper from L2 to 12 and wire nut the wires together. Note: There will be no wire on terminal 12.

R4140M replacements:

Check terminal 13 of the Q520 wiring subbase.

- If nothing is on 13, install the new R7140M1007.
- If 13 is jumpered to 8, remove the jumper and install R7140M1007.
- If 13 goes somewhere (assume a low fire switch because the system has a damper motor), remove J1 and J2 from the back of the R7140M1007.

**NOTE: J1 and J2 provide an input for the R7140M when the system does not have a spring return damper with a low fire switch.**

**Leaving J1 and J2 in place with either 13 jumpered to 8 or with the low fire switch will cause the blower motor to come on after the R7140M is installed and power is supplied to the system.**

**Generally, the following table will apply to select the R7140M1007 model and the status of jumpers J1 and J2.**

Table 6. J1/J2 Jumper Configuration for R4140M/PM720M.

Model	Purge Timer	Leave J1 & J2	Remove J1 and J2
R4140M1004/M1012	A1039	X	
R4140M1020/M1038	A1047		X
R4140M1046/M1053	A1062		X
R4140M1079 (GP101)	A1062	X	
R4140M1103/M1111	A1039	X	
R4140M1145/M1152	A1047		X
R4140M1160/M1178	A1062		X
R4140M1186	A1047		X
R4140M1194	ST7800A1062		
BC7000L1000 w/PM720M2002	ST7800A1062		X
BC7000L1000 w/PM720M2036	*	X	

\* Check terminal 8 and 15.  
 If jumpered, ST7800A1031 (7 second purge).  
 If not jumpered, ST7800A1039 (30 second purge).

## Mounting R7140 Relay Module

### Installing the Programmer (Fig. 3)

#### **⚠ WARNING**

##### **Electrical Shock Hazard.**

**Can cause severe injury, death or property damage.**

Disconnect power before installation to prevent electrical shock. More than one disconnect may be involved.

1. Open the master switch.
2. Make sure no subbase wiring is projecting out beyond the terminal blocks. Tuck in wiring against the back of the subbase so it does not interfere with the contacts.
3. Grasp the programmer chassis and engage the chassis hinge brackets with the pivot pins at the bottom of the subbase.
4. Swing the chassis inward until the spring connectors engage the knifeblade contacts. Push in until the contacts are fully engaged.
5. Tighten the chassis retaining screw securely.
6. Close the master switch to restore power.

### Removing the Programmer

1. Open the master switch.
2. Loosen the chassis retaining screw.
3. Pull outward on the top of the chassis.
4. Disengage the chassis hinge brackets from the subbase pivot pins.

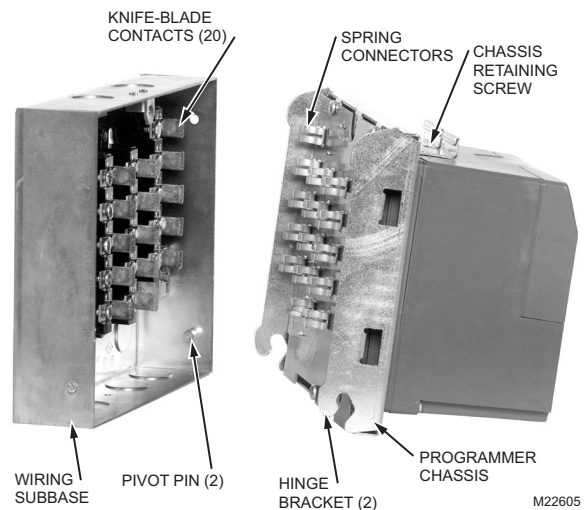
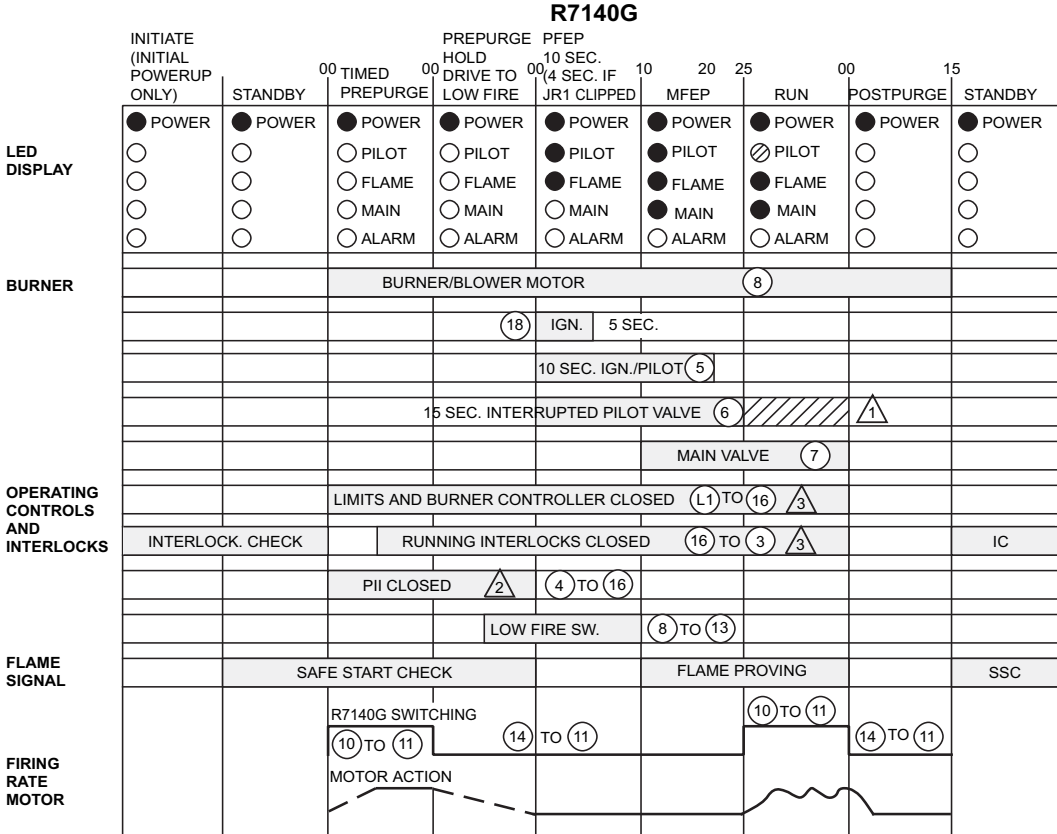

Fig. 3. Mounting the programmer on the subbase.





- ▲1 TERMINAL 6 HAS THE FOLLOWING OPTIONS:  
AS RECEIVED - INTERMITTENT PILOT  
JR2 CLIPPED - 15 SECOND MAIN FLAME ESTABLISHING PERIOD (INTERRUPTED PILOT)  
JR2 CLIPPED PLUS TERMINALS 8 - 15 JUMPERED - 30 SECOND MAIN FLAME ESTABLISHING PERIOD (INTERRUPTED PILOT)
  - ▲2 PII MEANS PRE-IGNITION INTERLOCK.
  - ▲3 FOR R7140G1000:  
L1 TO 4  
4 TO 3
- M23319

**Fig. 4. Operating sequence, R7140G1000/R7140G2008.**

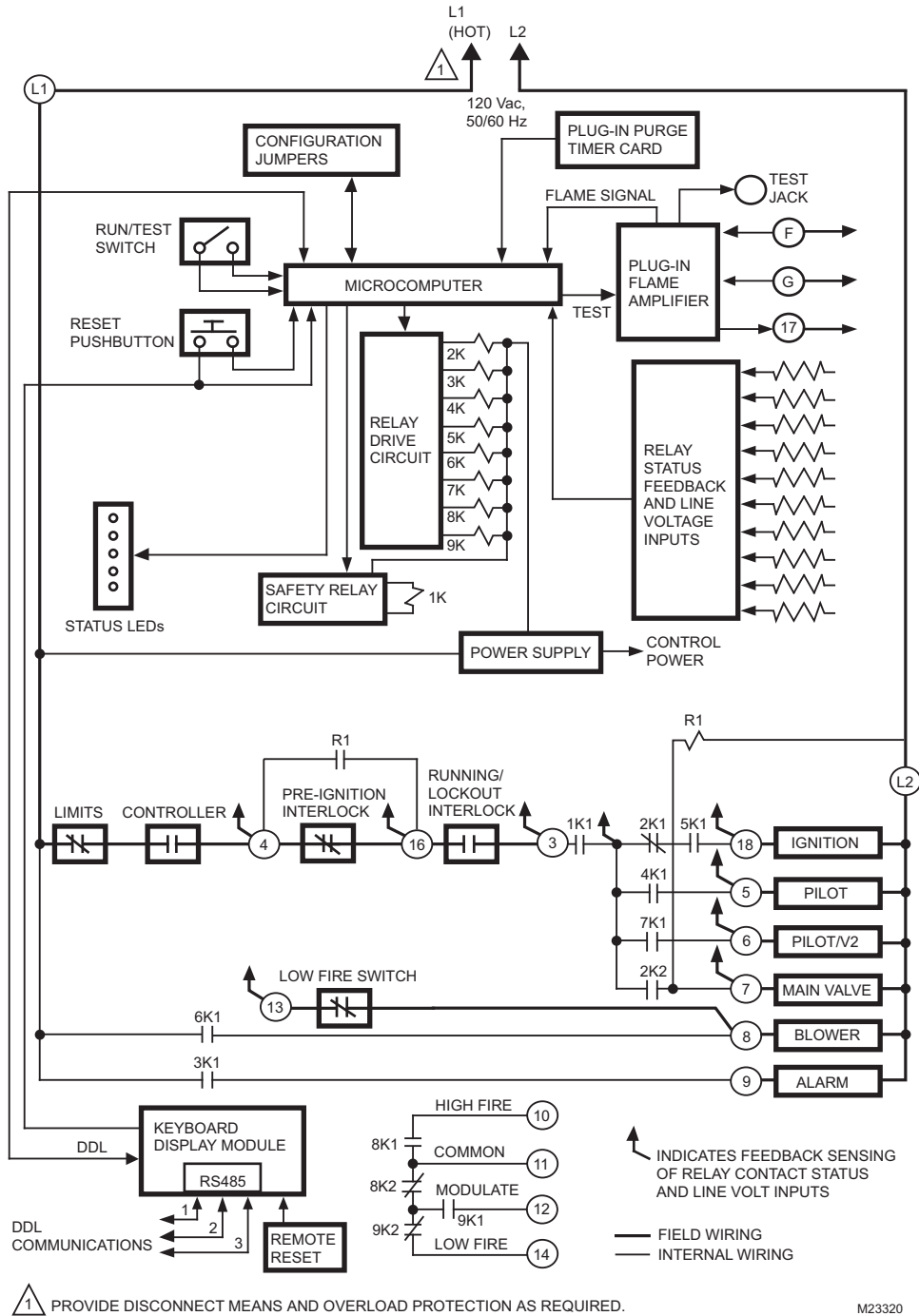
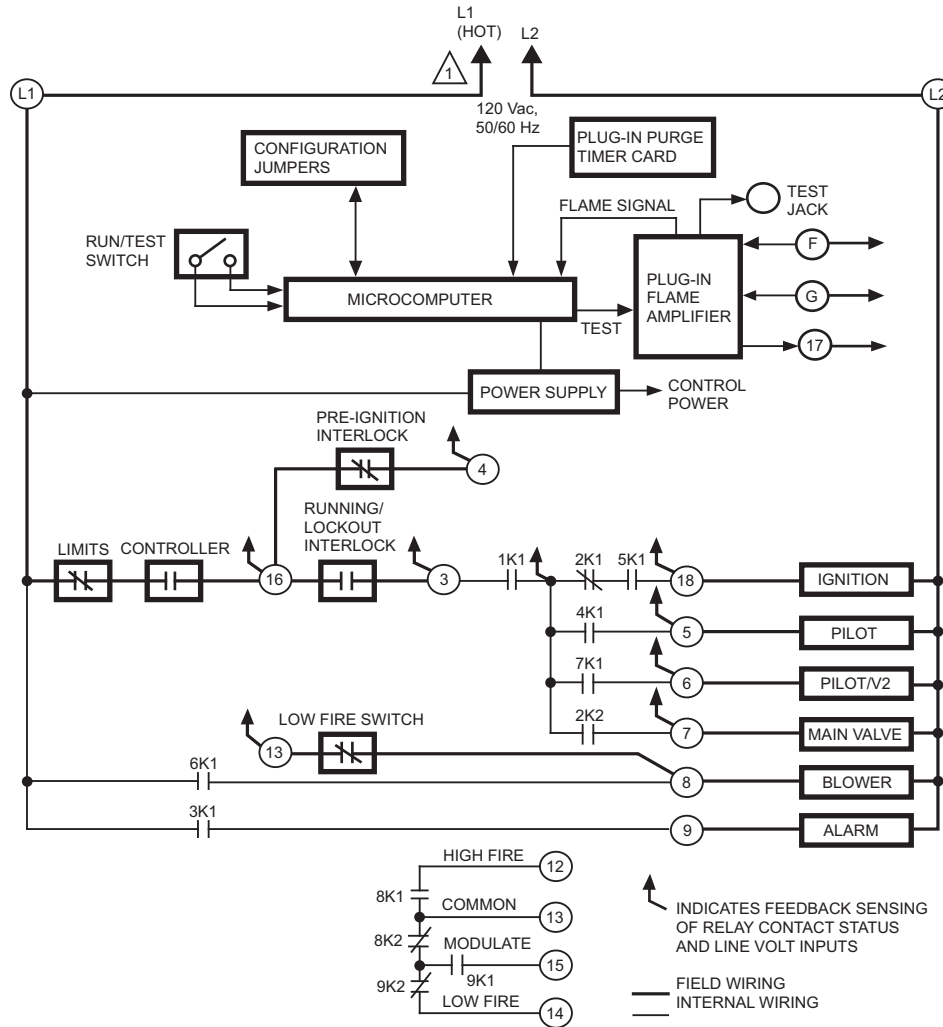

Fig. 5. Internal block diagram of the R7140G1000. (See Fig. 8 for detailed wiring.)



PROVIDE DISCONNECT MEANS AND OVERLOAD PROTECTION AS REQUIRED.

M23321

**Fig. 6. Internal block diagram of the R7140G2008. (See Fig. 7 for detailed wiring.)**

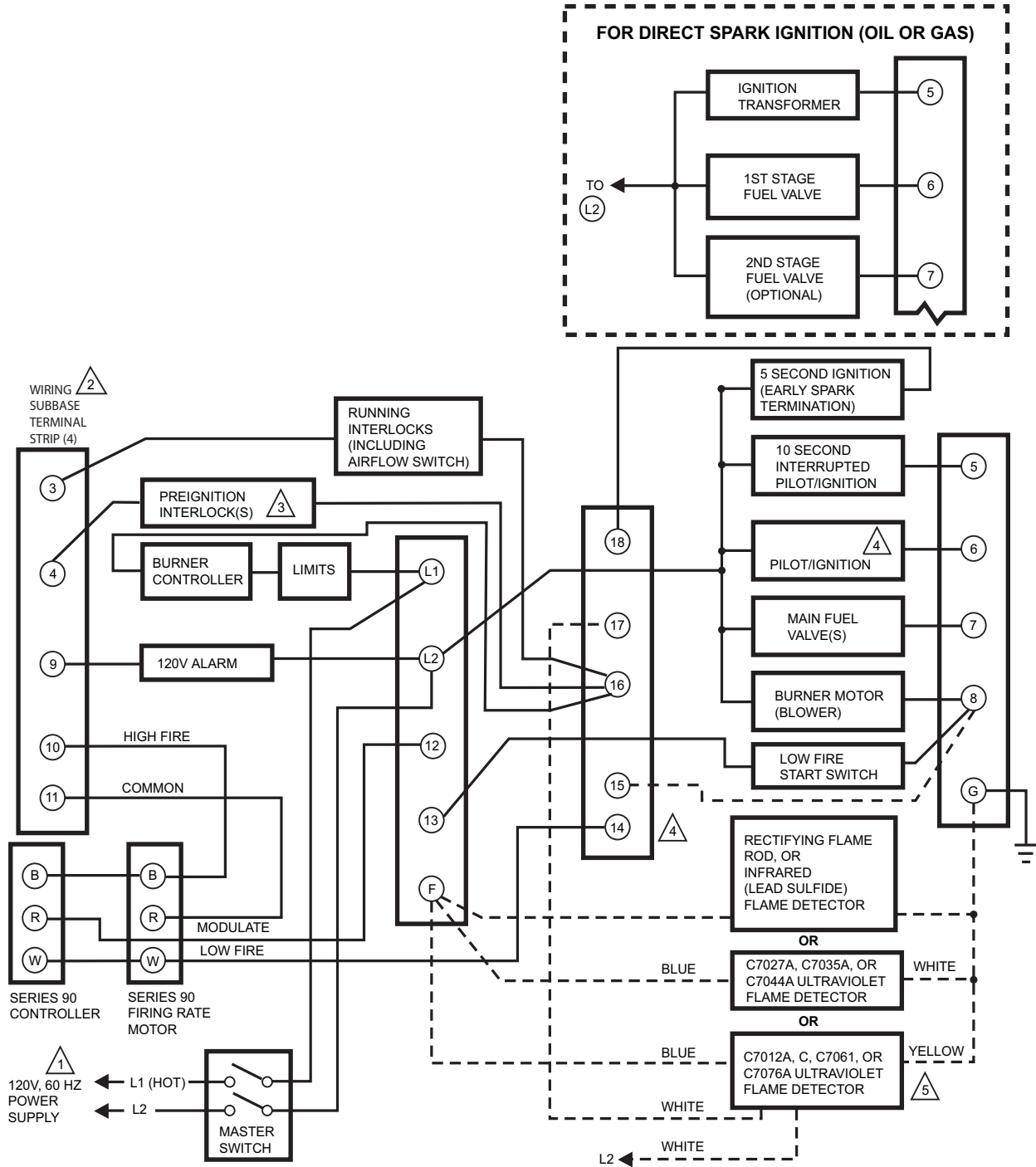

- △1 PROVIDE DISCONNECT MEANS AND OVERLOAD PROTECTION AS REQUIRED.
- △2 USE ALL NEC CLASS 1 WIRING.
- △3 START INTERLOCKS IF USED BECOME PREIGNITION INTERLOCKS - (MUST REMAIN CLOSED UNTIL IGNITION TRIALS BEGIN.)
- △4 TERMINAL 6 HAS THE FOLLOWING OPTIONS:  
AS RECEIVED - INTERMITTENT PILOT  
JR2 CLIPPED - 15 SECOND MAIN FLAME ESTABLISHING PERIOD  
JR2 CLIPPED AND JUMPER FROM 8-15 - 30 SECOND MAIN FLAME ESTABLISHING PERIOD.
- △5 C7012E.F NEEDS TO BE UPDATED TO C7061.

M22607B

**Fig. 7. Wiring diagram for R7140G2008 for application replacing R4140G with start Interlock or BC7000L1000 with PM720G.**

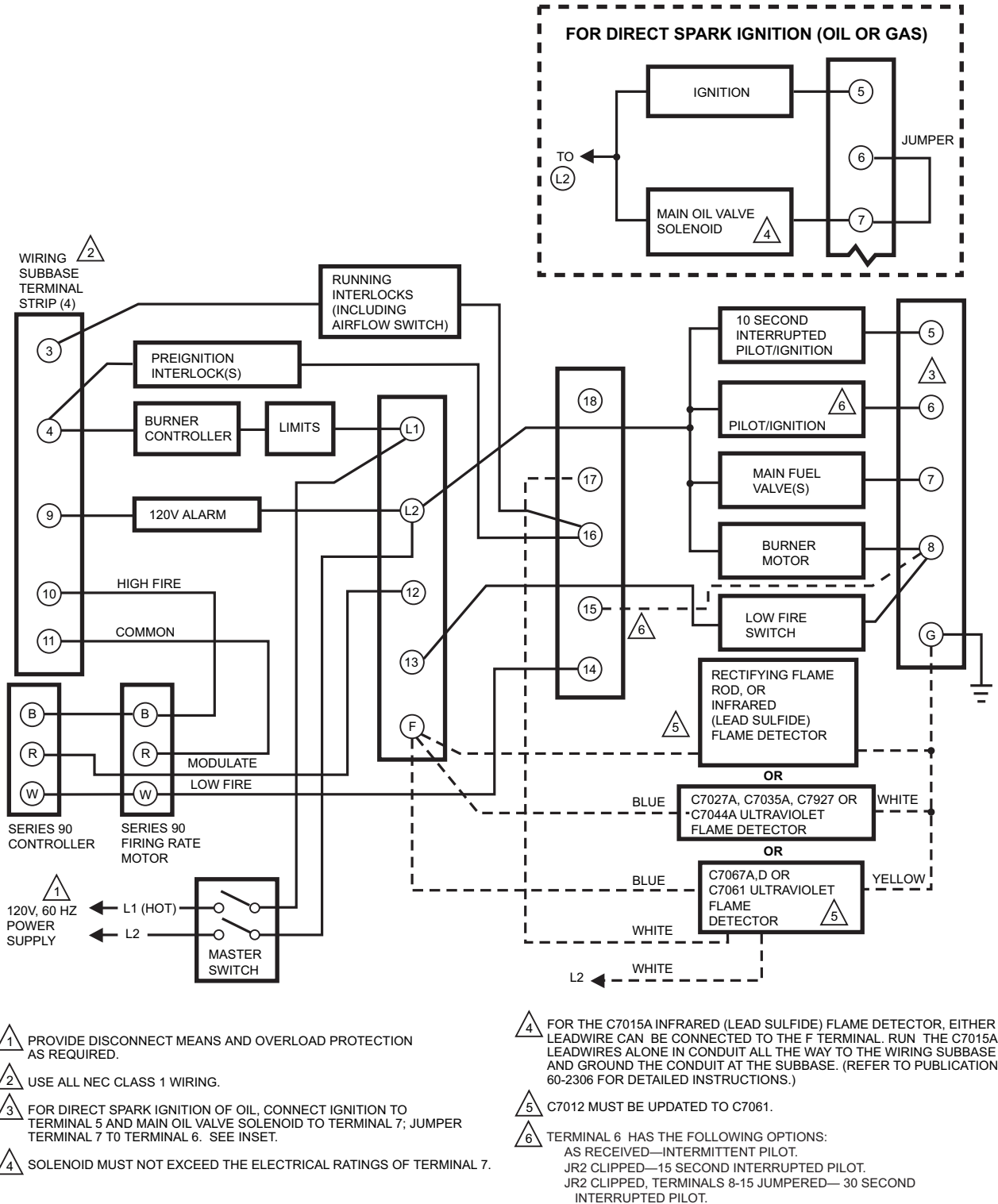
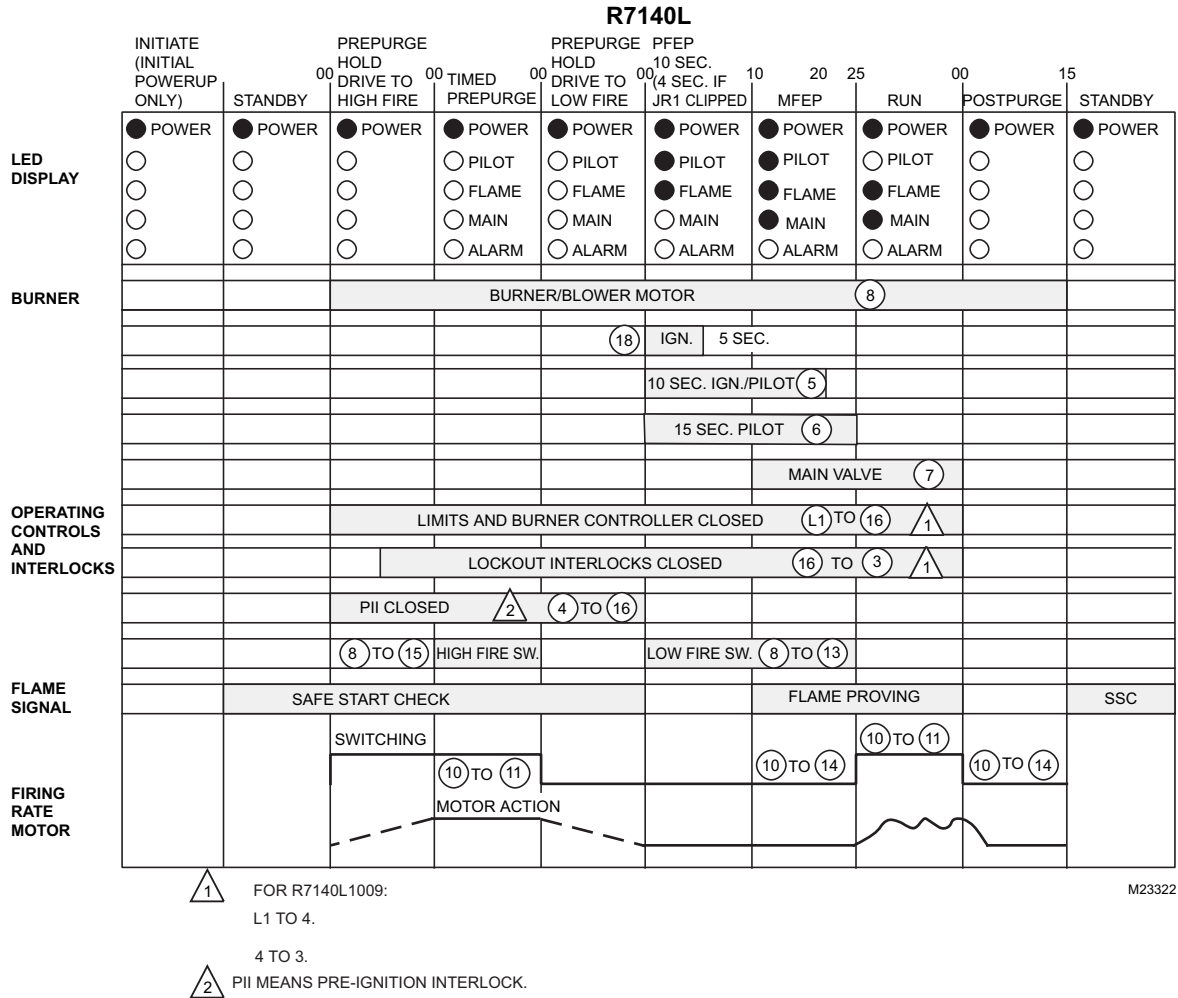

Fig. 8. Field wiring for R7140G1000 used for replacing R4140G Programmers with pre-ignition interlocks.

M22608B



**Fig. 9. Operating sequence, R7140L1009 and R7140L2007.**

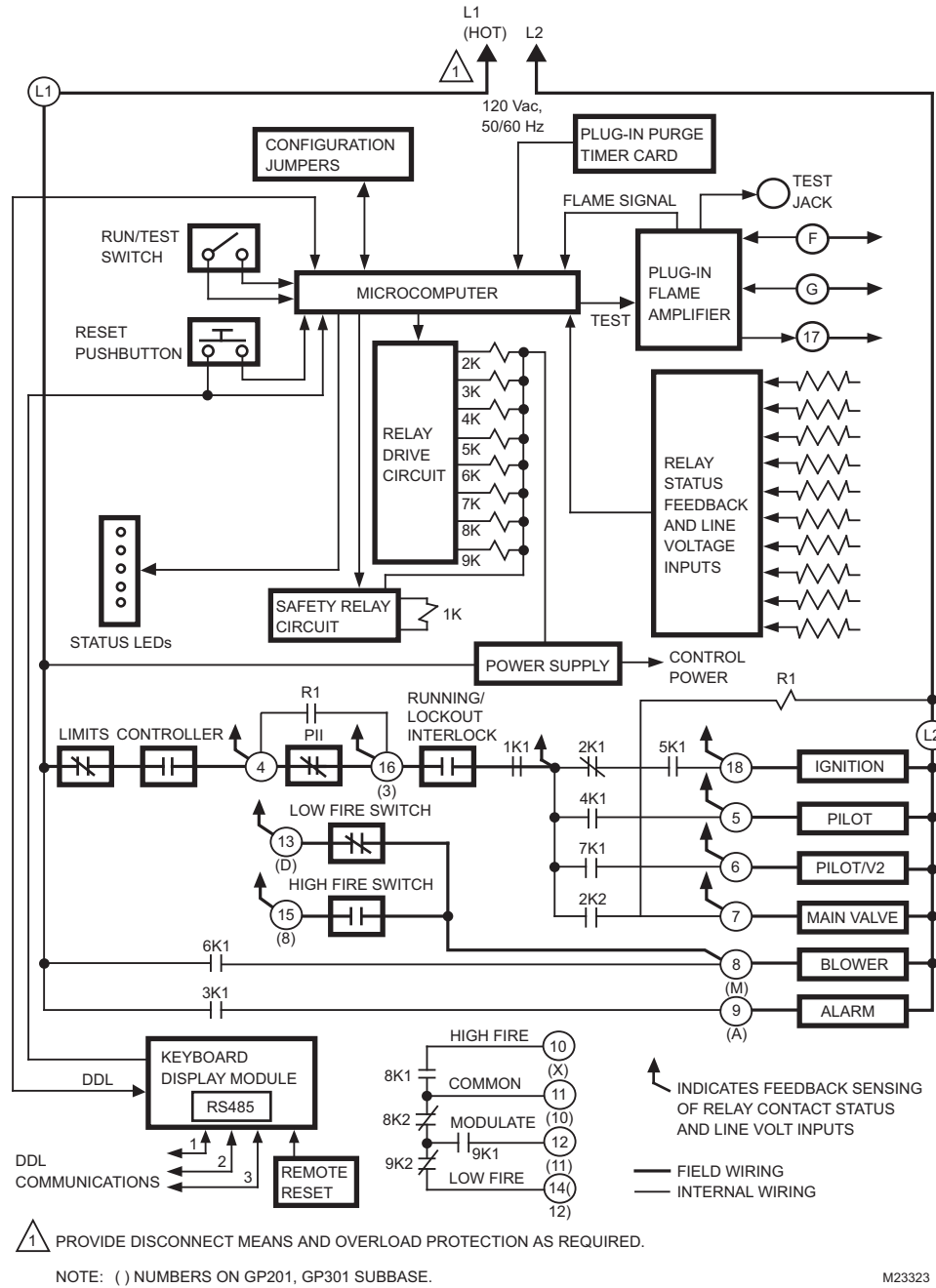

Fig. 10. Internal block diagram of the R7140L1009. (See Fig. 12 for detailed wiring.)

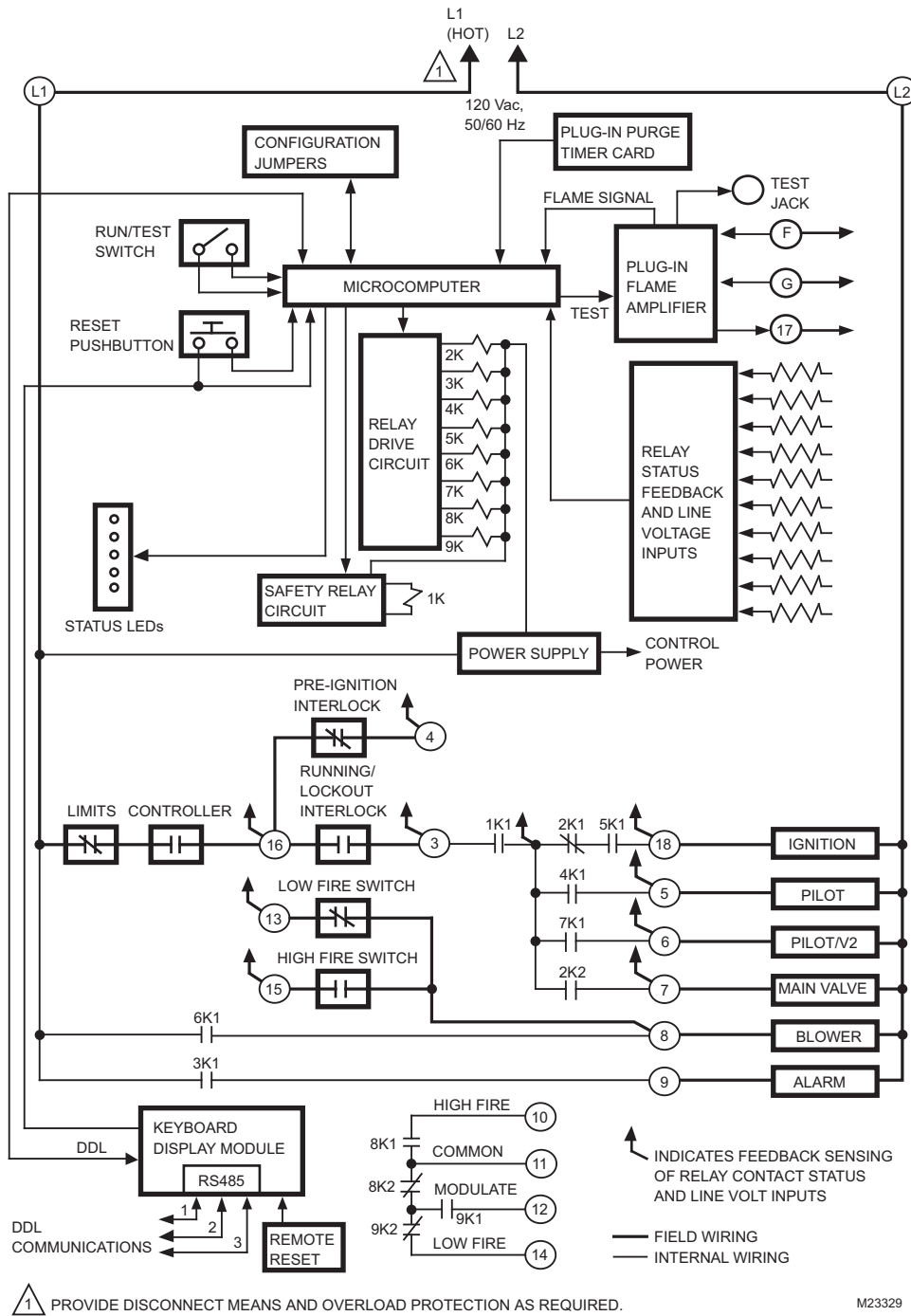
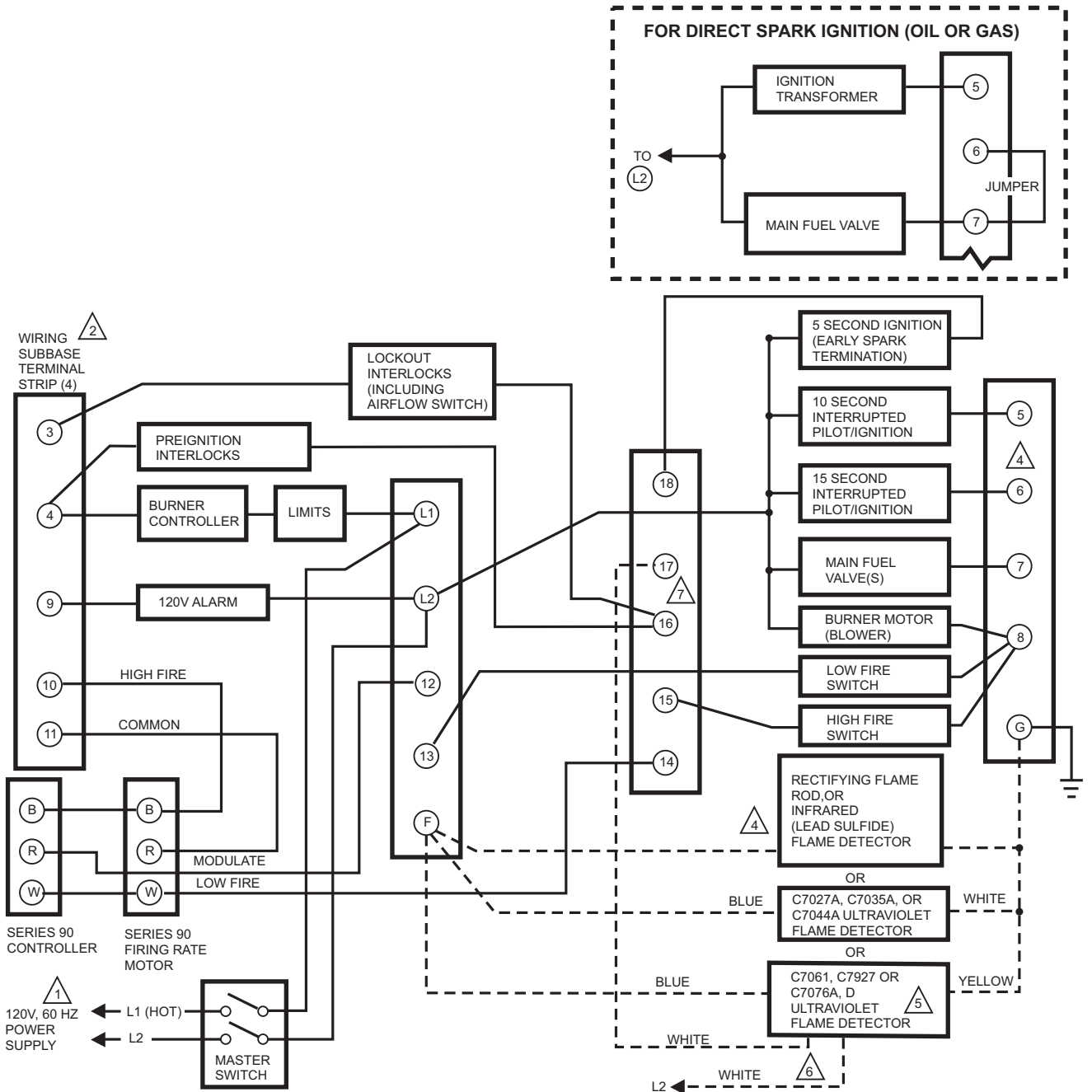

Fig. 11. Internal block diagram of the R7140L2007. (See Fig. 13 for detailed wiring.)





- 1 POWER SUPPLY. PROVIDE DISCONNECT MEANS AND OVERLOAD PROTECTION AS REQUIRED.
- 2 USE ALL NEC CLASS 1 WIRING.
- 3 FOR DIRECT SPARK IGNITION (OIL OR GAS) CONNECT THE IGNITION TRANSFORMER AND MAIN FUEL VALVE(S) AS SHOWN IN INSET.
- 4 FOR THE C7015A INFRARED (LEAD SULFIDE) FLAME DETECTOR, EITHER LEADWIRE CAN BE CONNECTED TO THE F TERMINAL. RUN THE C7015A LEADWIRES ALONE IN CONDUIT ALL THE WAY TO THE WIRING SUBBASE AND GROUND THE CONDUIT AT THE SUBBASE. (REFER TO PUBLICATION 60-2306 FOR DETAILED INSTRUCTIONS.)
- 5 C7061 OR C7076 MUST BE RATED FOR 120 V, 60Hz. TWO DETECTORS WITH THE SAME MODEL NUMBER CAN BE WIRED IN PARALLEL TO THE SAME TERMINALS. C7076A, D DOES NOT HAVE LEADWIRES. (FOR INSTRUCTIONS, SEE FORM NUMBERS: 60-2046 FOR C7012A, C MODELS WITH ELECTRON TUBES; 60-2044 FOR C7012A,C,E,F SOLID STATE MODELS; 95-8269 FOR THE C7076A.)
- 6 WHITE SHUTTER LEADWIRES ARE ONLY ON THE C7061A, E ULTRAVIOLET FLAME DETECTORS; C7076A, D ADJUSTABLE SENSITIVITY ULTRAVIOLET FLAME DETECTORS DO NOT HAVE LEADWIRES.
- 7 TERMINAL 17 IS USED ONLY FOR THE SHUTTER ON SELF-CHECKING C7061A, E, F OR C7076A, D FLAME DETECTORS.

M22610

**Fig. 12. Sample block diagram of field wiring for the R7140L1009, used for replacing R4140L Programmers with pre-ignition interlocks.**

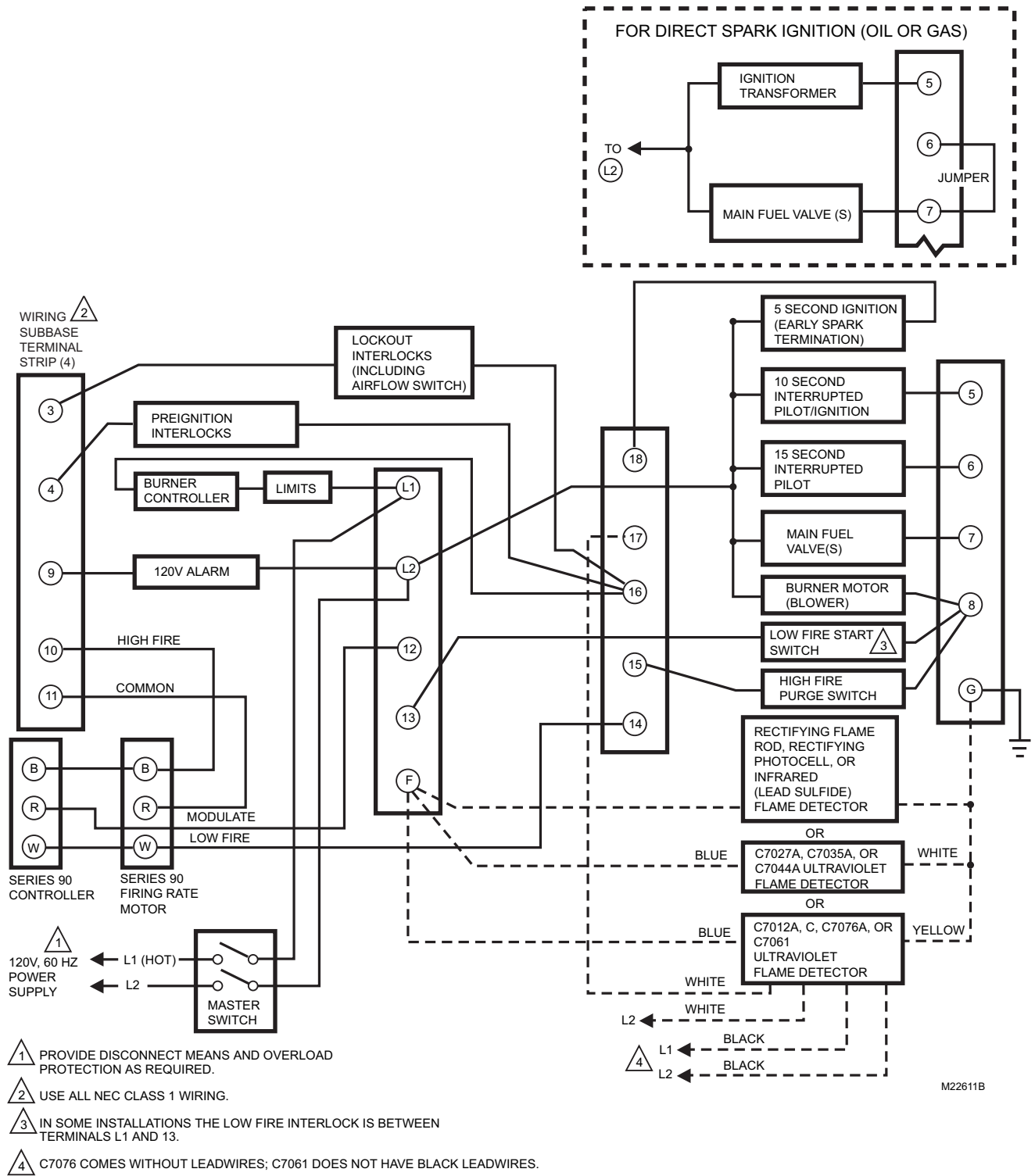

**Fig. 13. Block diagram of field wiring for the R7140L2007, used for replacing BC7000L1000 with PM720L.**

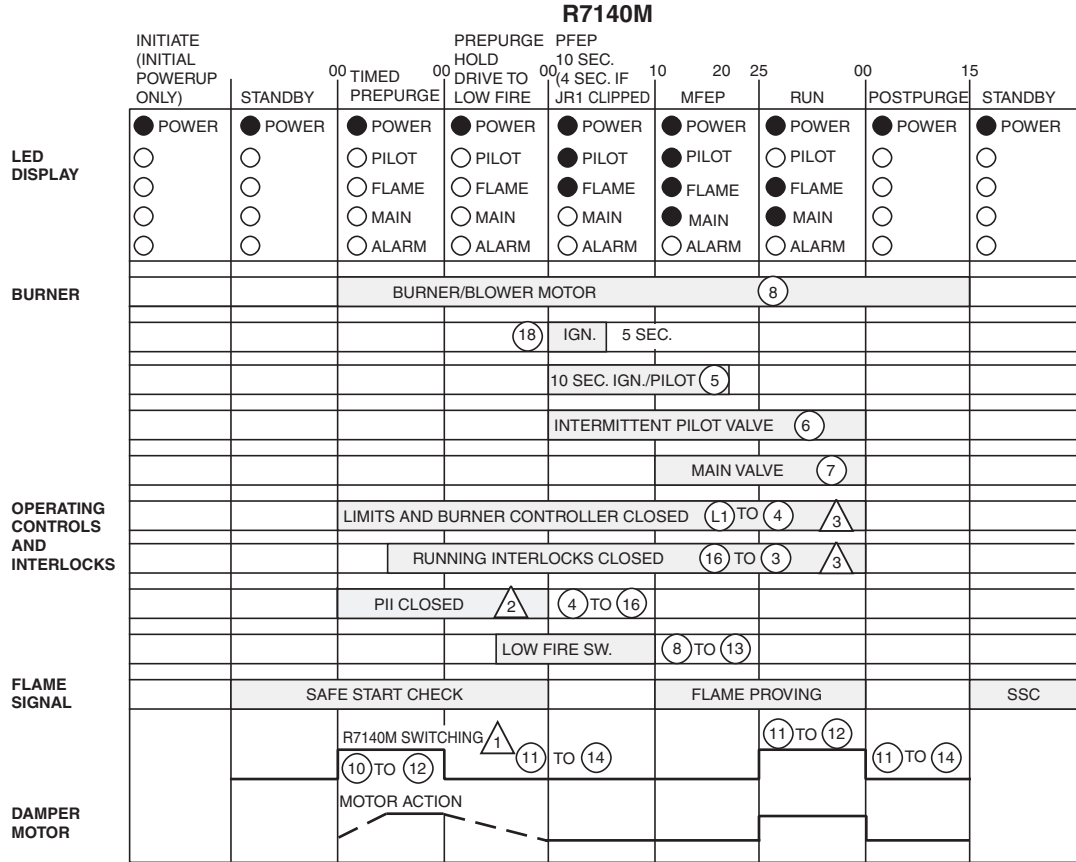

- △1 WHEN USING A SPRING RETURN ACTUATOR MOTOR, REMOVE J1 AND J2 JUMPERS LOCATED ON R7140M SUBBASE.
  - △2 PII MEANS PRE-IGNITION INTERLOCK.
  - △3 R7140M WHEN USED AS BC7000 REPLACEMENT ON R4140 WITH START INTERLOCKS L1 TO 16.
- M23331B

**Fig. 14. Operating sequence, R7140M.**

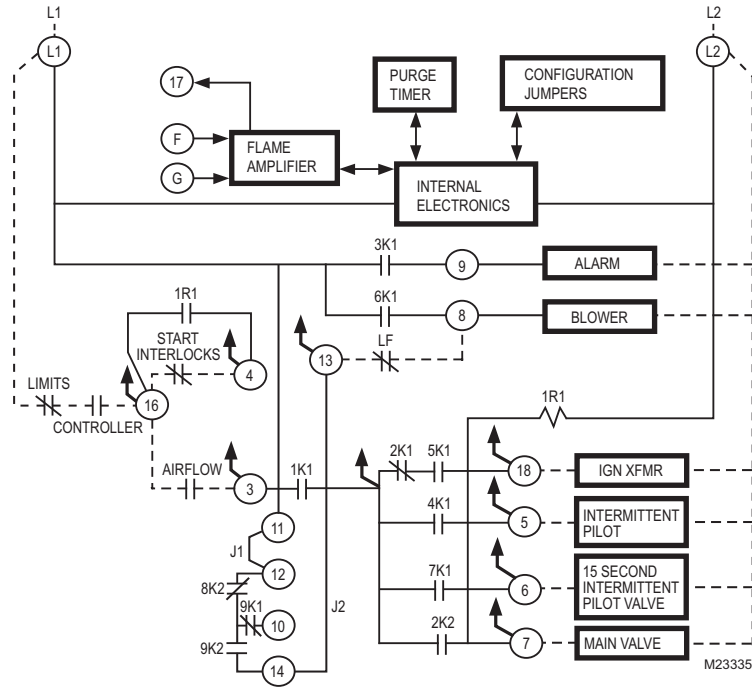

Fig. 15. Internal block diagram of the R7140M1007 with start interlocks. (See Fig. 17 for detailed wiring.)

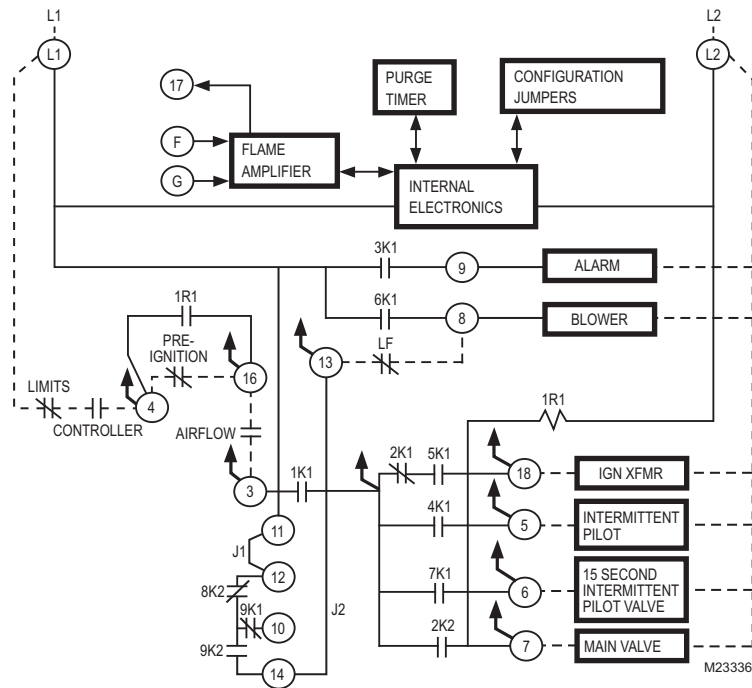
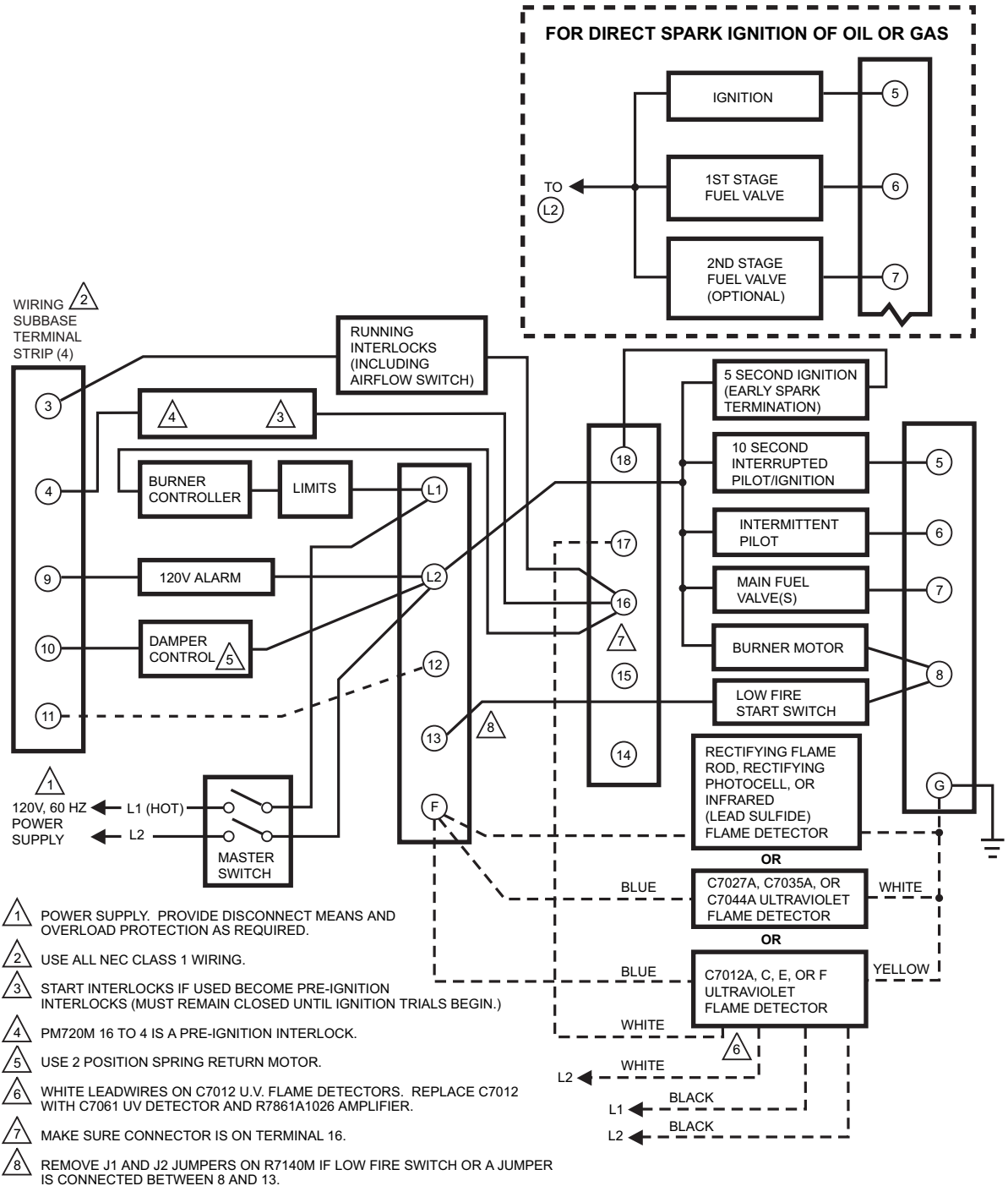

Fig. 16. Internal block diagram of the R7140M1007 with pre-ignition interlocks. (See Fig. 18 for detailed wiring.)



- 1 POWER SUPPLY. PROVIDE DISCONNECT MEANS AND OVERLOAD PROTECTION AS REQUIRED.
- 2 USE ALL NEC CLASS 1 WIRING.
- 3 START INTERLOCKS IF USED BECOME PRE-IGNITION INTERLOCKS (MUST REMAIN CLOSED UNTIL IGNITION TRIALS BEGIN.)
- 4 PM720M 16 TO 4 IS A PRE-IGNITION INTERLOCK.
- 5 USE 2 POSITION SPRING RETURN MOTOR.
- 6 WHITE LEADWIRES ON C7012 U.V. FLAME DETECTORS. REPLACE C7012 WITH C7061 UV DETECTOR AND R7861A1026 AMPLIFIER.
- 7 MAKE SURE CONNECTOR IS ON TERMINAL 16.
- 8 REMOVE J1 AND J2 JUMPERS ON R7140M IF LOW FIRE SWITCH OR A JUMPER IS CONNECTED BETWEEN 8 AND 13.

Fig. 17. R7140M1007 used on applications replacing R4140M Programmers with Start Interlocks or BC7000 with PM720M.

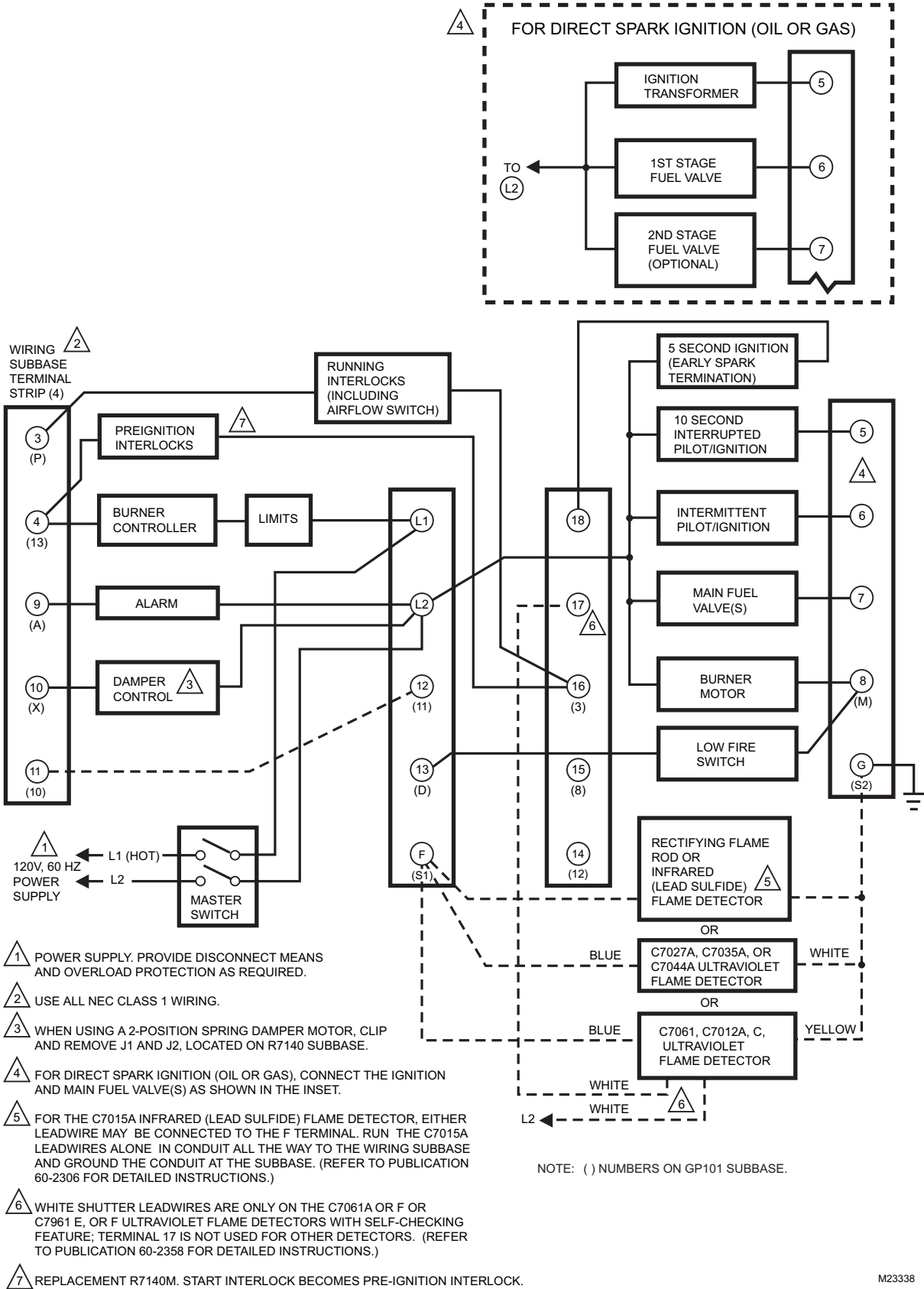

Fig. 18. Block diagram of field wiring for the R7140M1007, used for replacing R4140M Programmers with Pre-Ignition Interlocks.

## SAFETY SHUTDOWN

**Safety Shutdown (Lockout) occurs if any of the following occur during the indicated period:**

1. INITIATE Period:
  - a. Purge card is not installed or is removed.
  - b. Purge card is bad.
  - c. Configuration jumpers are changed (after 200 hours of operation).
  - d. AC line power errors occur; see Operation section.
  - e. Four minute INITIATE period has been exceeded.
2. STANDBY Period:
  - a. Flame signal is present after 240 seconds.
  - b. Pre-Ignition Interlock is open an accumulative time of 30 seconds.
  - c. Interlock check feature is enabled and the Interlock String (including airflow switch) is closed for 120 seconds with controller closed.
  - d. Ignition/pilot valve/intermittent pilot valve terminal is energized.
  - e. Main valve terminal is energized.
  - f. Internal system fault occurs.
  - g. Purge card is not installed or is removed.
  - h. Purge card is bad.
3. PREPURGE Period:
  - a. Pre-Ignition Interlock opens anytime during PRE-PURGE period (R7140L).
  - b. Flame signal is detected after first ten seconds during PREPURGE (R7140L).
  - c. High Fire Switch fails to close within 4 minutes and 15 seconds after the firing rate motor is commanded to drive to the high fire position at the start of PRE-PURGE (R7140L).
  - d. Low Fire Switch fails to close within 4 minutes and 15 seconds after the firing rate motor is commanded to drive to the low fire position at the end of PRE-PURGE.
  - e. Running Interlock does not close within 30 seconds (R7140G,M).
  - f. Lockout Interlock does not close within 10 seconds (R7140L).
  - g. Lockout Interlock opens during PREPURGE (R7140L).
  - h. Ignition/pilot valve/intermittent pilot valve terminal is energized.
  - i. Main valve terminal is energized.
  - j. Internal system fault occurs.
  - k. Purge card is removed.
  - l. Purge card is bad.
4. PILOT FLAME ESTABLISHING Period (PFEP):
  - a. Low Fire Switch opens.
  - b. Lockout Interlock opens (RM7140L).
  - c. Ignition/pilot valve/intermittent pilot valve terminal is not energized.
  - d. Early spark termination terminal is energized after five seconds.
  - e. No flame is present at the end of PFEP.
  - f. Main valve terminal is energized (R7140G,M).
  - g. Internal system fault occurs.
  - h. Purge card is removed.
  - i. Purge card is bad.
5. MAIN FLAME ESTABLISHING Period (MFEP):
  - a. Low Fire Switch Opens.
  - b. Lockout Interlock opens (R7140L).
  - c. Ignition/pilot valve/intermittent pilot valve terminal is not energized.
  - d. Main valve terminal is not energized.
  - e. No flame is present at the end of MFEP.
  - f. Internal system fault occurs.
  - g. Purge card is removed.
  - h. Purge card is bad.
6. RUN Period:
  - a. No flame is present.
  - b. Lockout Interlock opens (R7140L).
  - c. Interrupted pilot valve terminal is energized (R7140G,M).
  - d. Main valve terminal is not energized.
  - e. Internal system fault occurs.
  - f. Purge card is removed.
  - g. Purge card is bad.
7. POSTPURGE Period:
  - a. Pre-Ignition Interlock does not close in five seconds and opens after five-second time period.
  - b. Ignition/pilot valve/intermittent pilot valve terminal is energized.
  - c. Main valve terminal is energized.
  - d. Internal system fault occurs.
  - e. Purge card is removed.
  - f. Purge card is bad.

## OPERATION

### Sequence of Operation

The R7140 has the following operating sequences; see Fig. 4, 9, and 14. The R7140 LED provides positive visual indication of the program sequence: POWER, PILOT, FLAME, MAIN and ALARM. (Note: The Power LED is lit for 4 1/2 seconds and off for 1/2 seconds, to indicate normal operation.)

### Initiate

The R7140 enters the INITIATE sequence when the Relay Module is powered. The R7140 can also enter the INITIATE sequence if the Relay Module verifies voltage fluctuations of +10/-15 percent or frequency fluctuations of  $\pm 10$  percent during any part of the operating sequence. The INITIATE sequence lasts for ten seconds unless the voltage or frequency tolerances are not met. When the tolerances are not met, a hold condition is initiated for at least five seconds. When the tolerances are met, the INITIATE sequence restarts. If the condition is not corrected and the hold condition exists for four minutes, the R7140 locks out. Causes for hold conditions in the INITIATE sequence:

- a. AC line dropout is detected.
- b. AC line noise prevents a sufficient reading of the line voltage inputs.
- c. Low line voltage brownouts occur.

The INITIATE sequence also delays the burner motor starter from being energized and de-energized from an intermittent AC line input or control input.

### Standby

The R7140 is ready to start an operating sequence when the operating control determines a call for heat is present. The burner switch, limits, operating control and all microcomputer monitored circuits must be in the correct state for the R7140 to continue into the PREPURGE sequence.

## Normal Start-Up Pre-Purge

The R7140 provides a pre-purge timing selectable from two seconds to 30 minutes with power applied and the R7140 operating control indicating a call for heat:

- a. Running Interlocks, Pre-Ignition Interlocks, Burner Switch, Run/Test Switch, Lockout Interlocks and all microcomputer monitored circuits must be in the correct operating state.
- b. The blower motor output, terminal 8, is powered to start the PREPURGE sequence. The PREPURGE timing for the R7140L does not begin until the High Fire Switch is closed.

**NOTE: A jumpered High Fire Switch adds a 30-second hold before the purge time starts.**

- c. The Pre-Ignition Interlock input must remain closed throughout PREPURGE; otherwise, control returns to the STANDBY state and holds (30 seconds) for the R7140G,M or safety shutdown for the R7140L occurs.
- d. The Lockout Interlock or Running Interlock inputs (interlock circuit including Airflow Switch) must close by ten seconds into PREPURGE; otherwise, a recycle to the beginning of PREPURGE for the R7140G,M will happen or a safety shutdown for the R7140L occurs.
- e. When PREPURGE timing is complete, the firing rate motor drives to the low fire position. If a damper motor is used (R7140M), jumpers J1 and J2 should be removed from R7140 subbase.
- f. When the firing rate motor reaches low fire position, the Low Fire Switch, terminal 13, is energized to enter the Ignition Trial state.

**NOTE: A 30-second hold occurs for a jumpered Low Fire Switch before the ignition trial period begins.**

## Ignition Trials

1. Pilot Flame Establishing Period (PFEP):
  - a. With the firing rate motor at the low fire position:
    - (1) The pilot valve and ignition transformer, terminals 5, 6, and 18, are energized.
      - (a)The R7140G has an interrupted or intermittent pilot valve, terminal 6, depending on the selection of configuration jumper 2.
      - (b) The R7140L has a 15-second interrupted pilot valve, terminal 6.
      - (c)The R7140M has an intermittent pilot valve, terminal 6.

**NOTE: All of the R7140s have a ten-second interrupted pilot valve/ignition, terminal 5.**

- (2) During PFEP, the Low Fire Switch must remain closed. If it opens, a safety shutdown occurs.
- (3) The Pre-Ignition Interlock input is ignored throughout the Ignition Trial state.
- b. Flame must be proven by the end of the 10-second PFEP (four if JR1 is clipped) to allow the sequence to continue. If flame is not proven by the end of PFEP, a safety shutdown occurs.
- c. After five seconds, the ignition, terminal 18, is de-energized for early spark termination.

2. Main Flame Establishing Period (MFEP):
  - a. Terminal 7 is energized when the presence of flame is verified at the end of a 10-second Pilot Flame Establishing Period (PFEP) (four seconds if JR1 is clipped).
  - b. Terminal 5 is turned off 10 seconds after terminal 7 is energized.
  - c. Terminal 6 action:
    - (1) R7140L: De-energized 15 seconds after terminal 7 is energized.
    - (2) R7140G:
      - (a)Not turned off, or
      - (b)15 seconds after terminal 7 is energized and JR2 is clipped, or
      - (c)30 seconds after terminal 7 is energized and terminals 8 and 15 are jumpered and jumper JR2 is clipped.
    - (3) R7140M: Remain energized as long as call for heat is present.

## Run

1. Fifteen seconds after the main valve terminal 7 is energized and flame is maintained, the R7140 goes to Run.
2. The firing rate motor releases to modulation (R7140G,L). Damper motor is energized (R7140M).
3. The R7140 is now in RUN and remains in RUN until the controller input, terminal 16 or 4 (model dependent), opens, indicating that the demand is satisfied or a limit opened.

## Postpurge

The R7140 provides a 15-second POSTPURGE following the completion of the RUN period (call for heat ends). The blower motor output remains powered to drive all products of combustion and any unburned fuel from the combustion chamber. It also supplies combustion air to burn fuel being purged from the fuel line downstream of the fuel shutoff valve.

1. The main fuel valve and intermittent pilot valve, terminals 7 and 6, are de-energized and the firing rate motor is commanded to the low fire position to begin the POSTPURGE period.
2. After the 15-second POSTPURGE period is completed, the blower motor (terminal 8) is de-energized and the R7140 reenters Standby.

## Run/Test Switch



### WARNING

**Explosion Hazard.**

**Can cause serious injury or death.**

Do not use the Run/Test switch during the Pilot Flame Establishing Period for the R7140 when using Direct Spark Function, because it turns on the main gas valve, causing an accumulation of fuel in the burner.

The Run/Test Switch is located on the top side of the R7140, see Fig. 1. The Run/Test Switch allows the burner sequence to be altered as follows:



1. In Pre-Purge Drive To High Fire Position (R7140L), the Run/Test Switch, when placed in the TEST position, holds in PREPURGE with the firing rate motor in the High Fire position.
2. In the measured PREPURGE sequence, the Run/Test Switch, when placed in the TEST position, causes the PREPURGE timing to stop. The firing rate motor is in the High Fire position.
3. In Pre-Purge Drive to Low Fire position, the Run/Test Switch, when placed in the TEST position, holds the burner sequence in PREPURGE with the firing rate motor in the Low Fire position.
4. In PFEP, the Run/Test Switch, when placed in the TEST position, stops the timer during the first 8 seconds when a 10-second PFEP is selected or during the first 3 seconds when a 4-second PFEP is selected, allowing pilot-turn-down test and other burner adjustments to be made. This activates a 15-second flameout timer that permits pilot flame adjustment without nuisance safety shutdowns. The Run/Test Switch is ignored during PFEP for the R7140L if terminals 5 and 7 or 7 and 6 are jumpered.
5. During Run, the Run/Test Switch, when placed in the TEST position, drives the firing rate motor to the Low Fire position.

**NOTE:** When R7140 is switched to the Test mode, it stops and holds at the next Run/Test Switch point in the operating sequence. Make sure that the Run/Test Switch is in the RUN position before leaving the installation.

## SETTINGS AND ADJUSTMENTS

### Selectable Site-Configurable Jumpers

The R7140 has three site-configurable jumper options; see Fig. 19 and Table 7. If necessary, clip the site-configurable jumpers with side cutters and remove the resistors from the Relay Module.

The R7140M has two additional jumpers located on the back of the chassis. These must be cut if a spring return damper motor is used.

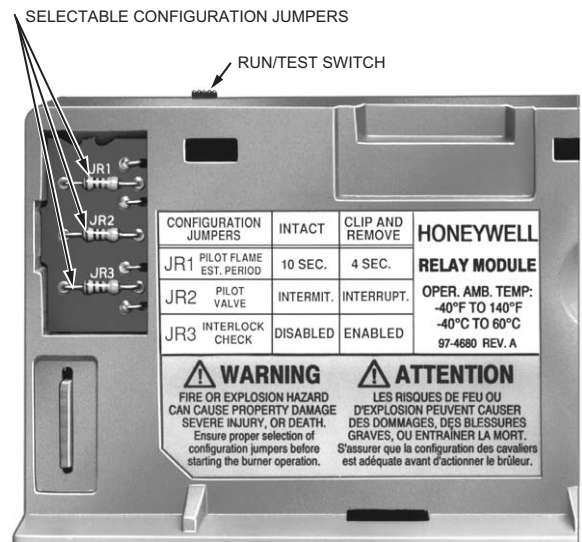

NOTE: CONFIGURATION JUMPERS SHOWN FOR RM7800G/RM7840G.

M12301

Fig. 19. Selectable site-configurable jumpers.

Table 7. Site Configurable Jumper Options.

Jumper Number	Description	Intact	Clipped	RM7800/RM7840 Type
JR1	Pilot Flame Establishing Period (PFEP)	10 seconds	4 seconds	All
JR2	Pilot Valve <sup>a</sup> /Main Flame Establishing Period (MFEP)	10 seconds Intermittent	15 or 30 seconds Interrupted <sup>b</sup>	R7140G
JR3	Start-up Interlock Check	Disabled	Enabled	All

<sup>a</sup> Pilot Valve/First Stage Oil Valve (Valve/Start) terminal 6.

<sup>b</sup> A 30 second MFEP can be accomplished by adding a jumper wire between terminals 15 and 8.

**SERVICE NOTE:** Clipping and removing these site-configurable jumpers enhances the level of safety. Removal after 200 hours of main valve operation will result in a hard lockout, Code 110.

## STATIC CHECKOUT

After checking all wiring, perform this checkout before installing the R7140 on the subbase. These tests verify the Q520A Wiring Subbase is wired correctly, and the external controllers, limits, interlocks, actuators, valves, transformers, motors and other devices are operating properly.

### WARNING

**Explosion and Electrical Shock Hazard.**  
**Can cause serious injury, death, or equipment damage.**

1. Close all manual fuel shutoff valve(s) before starting these tests.
2. Use extreme care while testing the system. Line voltage is present on most terminal connections when power is on.
3. Open the master switch before installing or removing a jumper on the subbase.
4. Before continuing to the next test, be sure to remove test jumper(s) used in the previous test.
5. Replace all limits and interlocks that are not operating properly. Do not bypass limits and interlocks.

### CAUTION

**Equipment Damage Hazard.**  
**Improper testing can damage equipment.**

Internal surge protectors can break down and conduct a current, causing the R7140 to fail the dielectric test or possibly destroy the internal lightning and high current protection. Do not perform a dielectric test with the R7140 installed.

## Equipment Recommended

1. Voltmeter (1M ohm/volt minimum sensitivity) set on the 0-300 Vac scale.
2. Two jumper wires; no. 14 wire, insulated, 12 inches (304.8 mm) long with insulated alligator clips at both ends.

3. When jumpered to Ignition, Pilot and Main Valves, use ammeter in series and verify proper current draw.

## General Instructions

1. Perform all applicable tests listed in Static Checkout, Table 8, in the order listed.
2. Make sure all manual fuel shutoff valve(s) are closed.
3. Perform only those tests designated for the specific R7140 model being tested.
4. Raise the setpoint of the operating controller to simulate a call for heat.
5. For each test, open the master switch and install the jumper wire(s) between the subbase wiring terminals listed in the Test Jumpers column.
6. Close the master switch before observing operation.
7. Read the voltage between the subbase wiring terminals listed in the Voltmeter column.
8. If there is no voltage or the operation is abnormal, check the circuits and external devices as described in the last column.
9. Check all wiring for correct connections, tight terminal screws, correct wire, and proper wiring techniques. Replace all damaged or incorrectly sized wires.
10. Replace faulty controllers, limits, interlocks, actuators, valves, transformers, motors and other devices as required.
11. Make sure normal operation is obtained for each required test before continuing the checkout.
12. After completing each test, be sure to remove the test jumper(s).

### WARNING

**Explosion Hazard.**  
**Can cause serious injury or death.**

Make sure all manual fuel shutoff valves are closed before performing static checkout.

Table 8. Static Checkout.

Test No.	R7140 Models	Test Jumpers	Voltmeter	Normal Operation	If Operation is Abnormal, Check the Items Listed Below
1	All	None	L1-L2	Line voltage at terminal L1.	1. Master Switch. 2. Power connected to the Master Switch. 3. Overload protection (fuse, circuit breaker, etc.) has not opened the power line.
2			16-L2	Line voltage at terminal 16 (4 on Pre-Ignition Interlock devices).	1. Limits. 2. Burner Controller.
3			4-L2	Line voltage at terminal 16.	1. Pre-Ignition interlocks.
4		L1-8	3-L2	1. Burner motor (fan or blower) starts. 2. Line voltage at terminal 3 within 10 seconds.	1. Burner motor circuit. a. Manual switch of burner motor. b. Burner motor power supply, overload protection, and starter. c. Burner motor. 2. Running or Lockout Interlocks (including Airflow Switch).
5		L1-18	—	Ignition spark (if ignition transformer is connected to terminal 18).	1. Watch for spark or listen for buzz. a. Ignition electrodes are clean. b. Ignition transformer is okay.

Table 8. Static Checkout. (Continued)

Test No.	R7140 Models	Test Jumpers	Voltmeter	Normal Operation	If Operation is Abnormal, Check the Items Listed Below
6	All	L1-5	—	1. Ignition spark (if ignition transformer is connected to terminal 5). 2. Automatic pilot valve opens (if connected to terminal 5).  <b>NOTE: Refer to wiring diagram of system being tested.</b>	1. Watch for spark or listen for buzz. a. Ignition electrodes are clean. b. Ignition transformer is okay. 2. Listen for click or feel head of valve for activation. a. Actuator, if used. b. Pilot valve.
7		L1-6	—	Same as test no. 6 for connections to terminal 5. If using direct spark ignition, check the first stage fuel valve(s) instead of the pilot valve.	Same as test no. 6. If using direct spark ignition, check the first stage fuel valve(s) instead of the pilot valve.
8		L1-7	—	Automatic main fuel valve(s) open. If using direct spark ignition on a model with intermittent pilot on terminal 6, check the optional second stage fuel valve, if used.	1. Listen for and observe operation of the main fuel valve(s) and actuator(s). 2. Valve(s) and actuator(s).
9		L1-9	—	Alarm (if used) turns on.	1. Alarm.
10	R7140G,L	L1-8 and 10-11	13-L2	Firing rate motor drives open; zero volts at terminal 13 after motor starts driving open.	1. Low Fire Start Switch. 2. Firing rate motor and transformer.
11	R7140G,L	L1-8 and 14-11	13-L2	Firing rate motor drives closed; line voltage at terminal 13 after motor is in Low Fire position.	1. Low Fire Start Switch. 2. Firing rate motor and transformer.
12	R7140G,L	L1-8 and 10-11	15-L2	Firing rate motor drives open; line voltage at terminal 15 after motor is in High Fire position.	1. High Fire Purge Switch. 2. Firing rate motor and transformer.
13	R7140L	L1-8 and 14-11	15-L2	Firing rate motor drives closed; zero volts at terminal 15 after motor starts driving closed.	1. Low Fire Start Switch. 2. Firing rate motor and transformer.
14	R7140G,L	11-12	—	1. Raise setpoint of Series 90 controller—firing rate motor should drive toward open. 2. Lower setpoint of Series 90 controller—firing rate motor should drive toward closed.	1. Series 90 Controller. 2. Firing rate motor and transformer.
15	R7140M with open damper contacts.	14-11	—	If damper motor is used, motor drives damper open.	Damper motor.
16	R7140M with open damper contacts.	L1-8	13-L2	If damper motor is used, motor drives open; line voltage at terminal 13 after motor is in Low Fire position.	1. Low Fire Start Switch. 2. Damper motor.
17	R7140M with open damper contacts.	L1-8 and L1-11	13-L2	If damper motor is used, motor drives open; zero volts at terminal 13.	1. Low Fire Start Switch. 2. Damper motor.
Final	All	 <b>CAUTION</b> <b>Equipment Damage Hazard.</b> <b>Improper wiring can damage equipment.</b> On completing these tests, open the master switch and remove all test jumpers from the subbase terminal. Also remove bypass jumpers from the low fuel pressure limits (if used) to prevent equipment damage.			

# SYSTEM CHECKOUT

**IMPORTANT**

Perform all Static Checkout Procedures for the applicable relay module shown in Table 8 before starting these procedures.

## WARNING

**Explosion Hazard.**  
**Can cause serious injury or death.**

Do not allow fuel to accumulate in the combustion chamber for longer than a few seconds without igniting to prevent danger of forming explosive mixture. Close manual fuel shutoff valve(s) if flame is not burning at end of specified time.

## WARNING

**Electric Shock Hazard.**  
**Can cause serious injury or death.**

1. Use extreme care while testing system. Line voltage is present on most terminal connections when power is on.
2. Open master switch before removing or installing R7140 Relay Module.

Make sure all manual fuel shutoff valve(s) are closed before starting initial lightoff check and Pilot Turndown tests.

Do not put the system in service until you have satisfactorily completed all applicable tests in this section and any others recommended by the original equipment manufacturer.

Limit trial for pilot to ten seconds. Limit the attempt to light main burner to two seconds after fuel reaches burner nozzle. Do not exceed manufacturer nominal lightoff time.

## CAUTION

**Equipment Malfunction or Damage Hazard.**  
**Incorrect wiring can cause equipment damage.**  
Each relay module type is unique. Using existing wiring on a relay module change can cause equipment damage.

**IMPORTANT**

1. If the system fails to perform properly, refer to the Troubleshooting section.
2. Repeat all required Checkout tests after all adjustments are made. All tests must be satisfied with the flame detector(s) in their final position.

## Equipment Recommended

S7800A Keyboard Display Module  
Volt-ohmmeter (1M ohm/volt minimum sensitivity) with:

- 0-300 Vac capability.
- 0-6000 ohm capability.
- 0-10 Vdc capability.

## Checkout Summary

Table 9 provides an overview of checkout steps performed for each applicable system.

See Installation Instructions for location of component parts and terminal locations.

**Table 9. Checkout Steps and Applicable Detection Systems.**

Checkout Step	Piloted Systems	DSI Systems	Infrared Flame Detectors	Flame Rod Systems	Ultraviolet Flame Detectors
Preliminary Inspection	X	X	X	X	X
Flame Signal Measurement	X	X	X	X	X
Initial Lightoff Check for Proved Pilot	X				
Initial Lightoff Check for Direct Spark Ignition		X			
Pilot Turndown Test	X				
Ignition Interference Test				X	
Hot Refractory Saturation Test			X		
Hot Refractory Hold-in Test	X	X	X	X	X
Ignition Spark Pickup					X
Response to Other Ultraviolet Sources					X
Flame Signal with Hot Combustion Chamber	X	X	X	X	X
Safety Shutdown Tests	X	X	X	X	X

## Preliminary Inspection

Perform the following inspections to avoid common problems. Make certain that:

1. Wiring connections are correct and all terminal screws are tight.
2. Flame detector(s) is clean, installed and positioned properly. Consult the applicable Instructions.
3. Combination of amplifier and flame detector(s) is correctly used. See the amplifier specifications.
4. Plug-in amplifier and purge card (if required) are securely in place.
5. Burner is completely installed and ready to fire; consult equipment manufacturer instructions. Fuel lines are purged of air.
6. Combustion chamber and flues are clear of fuel and fuel vapor.

7. Power is connected to the system disconnect switch (master switch).
8. Lockout is reset (reset button) only if the Relay Module is powered.
9. Run/Test Switch (if present) is in RUN position.
10. System is in STANDBY condition. STANDBY message is displayed in the S7800 Keyboard Display Module.
11. All limits and interlocks are reset.

## Flame Signal Measurement

See instructions provided with the amplifier.

## INITIAL LIGHTOFF CHECKS

### Proved Pilot Systems

Perform this check on all installations that use a pilot. It should immediately follow the preliminary inspection.

**NOTE: Low fuel pressure limits, if used, could be open. If so, bypass them with jumpers during this check.**

1. Open the master switch.
  2. Make sure that the manual main fuel shutoff valve(s) is closed. Open the manual pilot shutoff valve. If the pilot takeoff is downstream from the manual main fuel shutoff valve(s), slightly open the manual main valve to supply pilot gas flow. Make sure the main fuel is shut off just upstream from the burner inlet, or disconnect power from the automatic main fuel valve(s).
  3. Close the master switch and start the system with a call for heat by raising the setpoint of the operating controller; see the relay module sequence. The R7140 Relay Module should start a ten-second INITIATE sequence.
  4. Let the sequence advance to PILOT IGN (status is displayed on the Keyboard Display Module, if used), PILOT LED turns on, ignition spark should occur and the pilot should light. If the pilot ignites, the FLAME LED is energized. Go to step 7.
  5. If the pilot flame is not established in ten seconds (four seconds if configuration jumper JR1 is clipped), safety shutdown occurs. Let the sequence complete its cycle.
  6. Push the reset push button, and let the system recycle once. If the pilot still does not ignite, make the following ignition/pilot adjustments:
    - a. Open the master switch and remove the R7140 Relay Module from the subbase.
    - b. On the subbase, jumper L1 to the ignition terminal; refer to the appropriate wiring diagram to determine the proper terminal. Disconnect the leadwire to the pilot valve if it is connected to the same terminal.
    - c. Close the master switch to energize only the ignition transformer.
    - d. If the ignition spark is not strong and continuous, open the master switch and adjust the ignition electrode spark gap setting to the manufacturer recommendation.
    - e. Make sure the ignition electrodes are clean.
    - f. Close the master switch and observe the spark.
  - g. After a continuous spark is obtained, open the master switch and add a jumper on the subbase from terminal L1 power to the pilot terminal 5 or 6. Reconnect the leadwire from the pilot valve if it was disconnected in step b.
  - h. Close the master switch to energize both the ignition transformer and the pilot valve.
  - i. If the pilot does not ignite and if the ignition spark is still continuous, adjust the pressure regulator until a pilot is established.
  - j. When the pilot ignites properly and stays ignited, open the master switch and remove the jumper(s) from the terminals of the subbase.
  - k. Check for adequate bleeding of the fuel line.
  - l. Reinstall the R7140 Relay Module on the subbase, close the master switch, and then return to step 4.
7. When pilot ignites, measure the flame signal. If the pilot flame signal is unsteady or approaching the 1.25 Vdc minimum value, adjust the pilot flame size or detector sighting to provide a maximum and steady flame signal.
  8. Recycle the system to recheck lightoff and pilot flame signal.
  9. When the MAIN LED turns on, make sure the automatic main fuel valve is open; then smoothly open the manual main fuel shutoff valve(s) and watch for main burner flame ignition. When the main burner flame is established, go to step 16.
  10. If the main burner flame is not established within five seconds or the normal lightoff time as specified by the equipment manufacturer, close the manual main fuel shutoff valve(s).
  11. Recycle the system to recheck the lightoff and pilot flame signal.
  12. Smoothly open the manual fuel shutoff valve(s) and try lightoff again. (The first re-attempt may have been required to purge the lines and bring sufficient fuel to the burner.)
  13. If the main burner flame is not established within five seconds or the normal lightoff time specified by the equipment manufacturer, close the manual main fuel shutoff valves(s). Check all burner adjustments.
  14. If the main burner flame is not established after two attempts:
    - a. Check for improper pilot size.
    - b. Check for excess combustion air at Low Fire.
    - c. Check for adequate Low Fire fuel flow.
    - d. Check for proper gas supply pressure.
    - e. Check for proper valve operation.
    - f. Check for proper pilot flame positioning.
  15. Repeat steps 8 and 9 to establish the main burner flame; then go to step 16.
  16. With the sequence in RUN, make burner adjustments for flame stability and Btu input rating.
  17. Shut down the system by opening the burner switch or by lowering the setpoint of the operating controller. Make sure the main flame goes out. There may be a delay due to gas trapped between the valve(s) and burner. Make sure all automatic fuel valve(s) close.
  18. Restart the system by closing the burner switch and/or raising the setpoint of the operating controller. Observe that the pilot is established during PILOT IGN and the main burner flame is established during MAIN IGN within the normal lightoff time.
  19. Measure the flame signal. Continue to check for the proper signal through the RUN period. Check the signal at both High and Low Firing Rate positions and while modulating, if applicable.

20. Run the burner through another sequence, observing the flame signal for:
  - a. Pilot flame alone.
  - b. Pilot and main flame together.
  - c. Main flame alone (unless monitoring an intermittent pilot). Also observe the time it takes to light the main flame. Ignition of main flame should be smooth.
21. Make sure all readings are in the required ranges before proceeding.
22. Return the system to normal operation.

**NOTE: After completing these tests, open the master switch and remove all test jumpers from the subbase terminals, limits/controls or switches.**

## Direct Spark Ignition Systems

This check applies to gas and oil burners not using a pilot. It should immediately follow the preliminary inspection. Refer to the appropriate sample block diagram of field wiring for the ignition transformer and fuel valve(s) hookup.

**NOTE:** Low fuel pressure limits, if used, could be open. If so, bypass them with jumpers during this check.

1. Open the master switch.
2. Complete the normal ready-to-fire checkout of the fuel supply and equipment as recommended by the equipment manufacturer.
3. Close all manual main fuel shutoff valve(s). Check that the automatic fuel valve(s) is closed. Make sure fuel is not entering the combustion chamber.
4. Close the master switch and start the system with a call for heat by raising the setpoint of the operating controller; see the relay module sequencing. The program sequence should start the INITIATE sequence.
5. Let the sequence advance through PREPURGE (if applicable). Ignition spark should occur when the PILOT LED turns on. Listen for the click of the first stage fuel solenoid valve(s). The relay module locks out and the ALARM LED turns on.
6. Let the R7140 Relay Module complete its cycle.
7. Open the manual fuel shutoff valve(s).
8. Push the reset button and the relay module recycles the program sequence through PREPURGE (if applicable).
9. When the PILOT LED turns on, make sure that the first stage burner flame is established. If it is, go to step 15.
10. If the first stage burner flame is not established within four seconds, or within the normal lightoff time specified by the equipment manufacturer, close the manual fuel shutoff valve(s), and open the master switch.
11. Check all burner adjustments.
12. Wait about three minutes. Close the master switch, open the manual fuel shutoff valve(s), and try to light off the burner again. The first attempt may be required to purge the lines and bring sufficient fuel to the burner.
13. If the first stage burner flame is not established within four seconds, or within the normal lightoff time specified by the equipment manufacturer, close the manual fuel shutoff valve(s), and open the master switch.
14. If necessary, repeat steps 11 through 13 to establish the first stage burner flame. Then go to step 15.
15. When the first stage burner flame is established, the sequence advances to RUN. Make burner adjustments for flame stability and input rating. If a second stage is used, go to step 18.

16. Shut down the system by opening the burner switch or by lowering the setpoint of the operating controller. Make sure the burner flame goes out and all automatic fuel valves close.
17. If used, remove the bypass jumpers from the low fuel pressure limit and subbase.
18. If a second stage is used, make sure the automatic second stage fuel valve(s) opened. Check the lightoff as follows (or go to step 19):
  - a. Open the manual second stage fuel valve(s).
  - b. Restart the system by raising the setpoint of the operating controller.
  - c. When the first stage burner flame is established, watch for the automatic second stage fuel valve(s) to open. Observe that the second stage lights off properly.
  - d. Make burner adjustments for flame stability and input rating.
  - e. Shut down the system by lowering the setpoint of the operating controller. Make sure the burner flame goes out and all automatic fuel valves close.
  - f. Go to step 19.
19. Restart the system by closing the burner switch and/or raising the setpoint of the operating controller. Observe that the burner flame is established during PILOT IGN, within the normal lightoff time specified by the equipment manufacturer.
20. Measure the flame signal. Continue to check for the proper signal through the RUN period. Check the signal at both high and low firing rate positions and while modulating. Any pulsating or unsteady readings require further attention.
21. Make sure all readings are in the required ranges before proceeding.

**NOTE: On completing these tests, open the master switch and remove all test jumpers from the subbase terminals, limits/controls or switches.**

22. Return the system to normal operation.

## PILOT TURNDOWN TEST (ALL INSTALLATIONS USING A PILOT)

Perform this check on all installations that use a pilot. The purpose of this test is to verify that the main burner can be lit by the smallest pilot flame that can hold in the flame amplifier and energize the FLAME LED. Clean the flame detector(s) to make sure that it detects the smallest acceptable pilot flame. If using AMPLI-CHECK™ or self-checking amplifier and 1M ohm/volt meter, the flame signal fluctuates every time the amplifier does a self-check or a shutter check.

**NOTE: Low fuel pressure limits, if used, could be open. If so, bypass them with jumpers during this test.**

1. Open the master switch.
2. Close the manual main fuel shutoff valve(s).
3. Connect a manometer (or pressure gauge) to measure pilot gas pressure during the turndown test.
4. Open the manual pilot shutoff valve(s).
5. Close the master switch and start the system with a call for heat. Raise the setpoint of the operating controller. The 7800 Series sequence should start, and PRE-PURGE (if applicable) should begin.

- After the PILOT LED turns on in interrupted pilot applications, set the Run/Test Switch to the TEST position to stop the sequence. The FLAME LED comes on when the pilot ignites.

**NOTE:** If the sequence does not stop, reset the system and make sure you set the Run/Test Switch to TEST within the first eight seconds of the PILOT IGN sequence.

**IMPORTANT**

*You have 0.8 second or three seconds, depending on PFEP selected, to position the Run/Test Switch to the TEST position to stop the sequence after the start of the PILOT IGN period.*

- Turn down the pilot pressure very slowly, reading the manometer (or pressure gauge) as it drops. Stop instantly when the FLAME LED goes out. Note the pressure. The pilot is at the minimum turndown position. Immediately turn up the pilot pressure until the FLAME LED comes on again or the flame signal increases to 1.25 Vdc.

**NOTE:** If there is no flame for 15 seconds with the RUN/TEST switch in the TEST position, the relay module locks out.

- Repeat step 7 to verify the pilot gas pressure reading at the exact point the FLAME LED light goes out.
- Increase the pilot pressure immediately until the FLAME LED comes on, and then turn it down slowly to obtain a pressure reading just above the dropout point or until the flame signal increases to 1.25 Vdc.
- Set the Run/Test Switch in the RUN position (if used) and let the sequence proceed. When the MAIN LED turns on, make sure the automatic main fuel valve(s) opens; then smoothly open the manual main fuel shutoff valve(s) (or any other manually-opened safety shutoff valve(s), if used) and watch for main burner ignition. If the main burner flame is established, go to step 18.

**NOTE:** This step requires two people, one to open the manual valve(s) and one to watch for ignition.

- If the main burner flame is not established within five seconds, or within the normal lightoff time specified by the equipment manufacturer, close the manual main fuel shutoff valve(s) and open the master switch. If the light-off is rough, the pilot flame size is too small.
- Close the master switch to recycle the burner and stop the sequence in the PILOT period by using the Run/Test Switch.
- Increase the pilot flame size by increasing its fuel flow until a smooth main flame is accomplished.
- Reposition the flame scanner sight tube or use orifices until the pilot flame signal voltage is in the range of 1.25 to 1.50 Vdc.
- When the main burner lights reliably with the pilot at turndown, disconnect the manometer (or pressure gauge) and turn up the pilot gas flow to that recommended by the equipment manufacturer.
- If used, remove the bypass jumpers from the subbase terminals, limits/controls, or switches.
- Run the system through another cycle to check for normal operation.
- Return the system to normal operation.

## IGNITION INTERFERENCE TEST (ALL FLAME RODS)

Ignition interference can subtract from (decrease) or add to (increase) the flame signal. If it decreases the flame signal enough, it causes a safety shutdown. If it increases the flame signal, it could cause the FLAME LED to come on when the true flame signal is below the minimum acceptable value.

Start the burner and measure the flame signal with both ignition and pilot (or main burner) on, and then with only the pilot (or main burner) on. Any significant difference (greater than 0.5 Vdc) indicates ignition interference.

### To Eliminate Ignition Interference

- Make sure there is enough ground area.
- Be sure the ignition electrode and the flame rod are on opposite sides of the ground area.
- Check for correct spacing on the ignition electrode:
  - 6000V systems—1/16 to 3/32 in. (1.6 to 2.4 mm).
  - 10,000V systems—1/8 in. (3.2 mm).
- Make sure the leadwires from the flame rod and ignition electrode are not too close together.
- Replace any deteriorated leadwires.
- Try wrapping the ignition wire with an insulated wire (No. 18 stranded, for example). See Fig. 13.
- Strip the insulation nearest the ignitor and ground it; also, strip the insulation nearest the ignition transformer and ground it.
- If the problem cannot be eliminated, consider changing the system to an ultraviolet flame detection system.

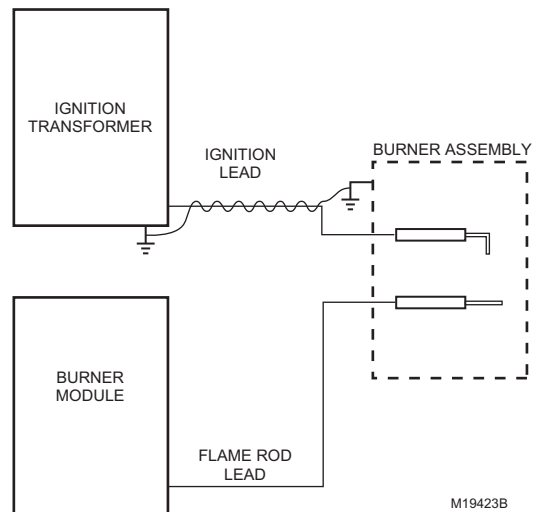

Fig. 20. Eliminating ignition interference.

## Hot Refractory Saturation Test (All Infrared Detectors)

Start the burner and monitor the flame signal during the warm-up period. A decrease in signal strength as the refractory heats up indicates hot refractory saturation. If saturation is extreme, the flame signal drops below 1.25 Vdc and the system shuts down as though a flame failure occurred.

If hot refractory saturation occurs, the condition must be corrected. Add an orifice plate in front of the cell to restrict the viewing area, lengthen the sight pipe or decrease the pipe size (diameter). Continue adjustments until hot refractory saturation is eliminated.

## Hot Refractory Hold-in Test (Rectifying Photocell, Infrared Detectors, Ultraviolet Detectors)

This condition can delay response to flame failure and also can prevent a system restart if hot refractory is detected.

Infrared (lead sulfide) detectors can respond to infrared rays emitted by a hot refractory, even when the refractory has visibly ceased to glow. Infrared radiation from a hot refractory is steady, but radiation from a flame has a flickering characteristic. The infrared detection system responds only to flickering infrared radiation; it can reject a steady signal from hot refractory. The refractory steady signal can be made to fluctuate if it is reflected, bent or blocked by smoke or fuel mist within the combustion chamber. Be careful when applying an infrared system to verify its response to flame only.

The ultraviolet detector can respond to hot refractory above 2300°F (1371°C).

1. Operate the burner until the refractory reaches its maximum temperature (Infrared Only). If the installation has a multi-fuel burner, burn the heavier fuel that is most likely to reflect, bend or obscure the hot refractory steady infrared radiation.
2. When the maximum refractory temperature is reached, close all manual fuel shutoff valves, or open the electrical circuits of all automatic fuel valves.
3. Visually observe when the burner flame or FLAME LED goes out. If this takes more than three seconds, the infrared detector is sensing hot refractory.
4. Immediately terminate the firing cycle. Lower the setpoint to the operating controller, or set the Fuel Selector Switch to OFF. Do not open the master switch.

**NOTE: Some burners continue to purge oil lines between the valves and nozzles even though the fuel valves are closed. Terminating the firing cycle (instead of opening the master switch) allows purging the combustion chamber. This reduces a buildup of fuel vapors in the combustion chamber caused by oil line purging.**

5. If the detector is sensing hot refractory, correct the condition by one or more of the following procedures:
  - a. Add an orifice plate in front of the cell to restrict the viewing area of the detector.
  - b. Resight the detector at a cooler, more distant part of the combustion chamber. Make sure the detector properly sights the flame.
  - c. Try lengthening the sight pipe or decreasing the pipe size (diameter).

For details, refer to the detector Instructions and the equipment Operating Manual. Continue adjustments until hot refractory hold-in is eliminated.

## IGNITION SPARK RESPONSE TEST (ALL ULTRAVIOLET DETECTORS)

Test to make certain that the ignition spark is not actuating the FLAME LED:

1. Close the pilot and main burner manual fuel shut-off valve(s).
2. Start the burner and use the Run/Test Switch (if available) to stop the sequence in the PILOT IGN period. Ignition spark should occur, but the flame signal should not be more than 0.5 Vdc.
3. If the flame signal is higher than 0.5 Vdc and the FLAME LED does come on, consult the equipment operating manual and resight the detector farther out from the spark, or away from possible reflection. It may be necessary to construct a barrier to block the ignition spark from the detector view. Continue adjustments until the flame signal due to ignition spark is less than 0.5 Vdc.

**NOTE: The Honeywell Q624A and Q652B Solid State Spark Generators prevent detection of ignition spark when properly applied with C7027, C7035, C7044 or C7061 Ultraviolet Flame Detectors. The Q624A and Q652B are only for use with gas pilots.**

## Response To Other Ultraviolet Sources

Some sources of artificial light (such as incandescent or fluorescent bulbs, mercury sodium vapor lamps and daylight) produce small amounts of ultraviolet radiation. Under certain conditions, an ultraviolet detector responds to these sources as if it is sensing a flame. To check for proper detector operation, check the Flame Failure Response Time (FFRT) and conduct Safety Shutdown Tests under all operating conditions.

## Flame Signal With Hot Combustion Chamber (All Installations)

1. With all initial start-up tests and burner adjustments completed, operate the burner until the combustion chamber is at the maximum expected temperature.
2. Observe the equipment manufacturer warm-up instructions.
3. Recycle the burner under these hot conditions and measure the flame signal. Check the pilot alone, the main burner flame alone, and both together (unless monitoring only the pilot flame when using an intermittent pilot, or only the main burner flame when using DSI). Check the signal at both High and Low Firing Rate positions and while modulating, if applicable.
4. Check the FFRT of the flame amplifier and relay module.
5. Lower the setpoint of the operating controller and observe the time it takes for the burner flame to go out. This should be within the maximum FFRT.
6. If the flame signal is too low or unsteady, check the flame detector temperature. Relocate the detector if the temperature is too high.
7. If necessary, realign the sighting to obtain the proper signal and response time.



8. If the response time is still too slow, replace the Plug-in Flame Signal Amplifier.
9. If the detector is relocated or resighted, or the amplifier is replaced, repeat all required Checkout tests.

## SAFETY SHUTDOWN TESTS (ALL INSTALLATIONS)

Perform these tests at the end of Checkout, after all other tests are completed. If used, the external alarm should turn on. Press the RESET pushbutton on the relay module to restart the system.

1. Opening a Preignition Interlock during the STANDBY or PREPURGE period (R7140L - Lockout; R7140G and M - Standby Hold 40 seconds, then Lockout).
  - a. Safety shutdown occurs.
2. Opening a Lockout Interlock during PREPURGE, PILOT IGN, MAIN IGN or RUN period (R7140L Only).
  - a. R7140G and R7140M go to Standby.
  - b. Safety shutdown occurs.
3. Detection of flame 40 seconds after entry to STANDBY from RUN. Detection of flame from ten seconds up to 30 seconds into PREPURGE time.
  - a. Simulate a flame to cause the flame signal voltage level to be at least 1.25 Vdc for 40 seconds after entry to STANDBY from RUN and also simulate a flame signal for 10 seconds to 30 seconds for PREPURGE.
  - b. Flame LED is on.
  - c. Safety shutdown occurs after 40 seconds.
4. Failure to ignite pilot.
  - a. Close pilot and main fuel manual shutoff valve(s).
  - b. Cycle burner on.
  - c. Automatic pilot valve(s) should be energized but the pilot cannot ignite.
  - d. Safety shutdown occurs.
5. Failure to ignite main (only interrupted pilot application).
  - a. Open the manual pilot valve(s); leave the main fuel manual shutoff valve(s) closed.
  - b. Depress the reset button.
  - c. Start the system.
    - d. The pilot should ignite and the flame signal should be at least 1.25 Vdc but the main burner cannot light.
    - e. The flame signal should drop below 1.25 Vdc within the FFRT of the amplifier and the relay module after the interrupted pilot goes out.
    - f. Safety shutdown occurs.
6. Loss of flame during RUN.
  - a. Open the main fuel manual shutoff valve(s) and open manual pilot shutoff valve(s).
  - b. Depress the reset button.
  - c. Start the system. Start-up should be normal and the main burner should light normally.
  - d. After the sequence is in the normal RUN period for at least ten seconds with the main burner firing, close the manual main fuel shutoff valve(s) to extinguish the main burner flame. (On intermittent pilot applications, also, close the pilot manual shutoff valve.)
  - e. The flame signal should drop below 1.25 Vdc within the FFRT of the amplifier and the relay module after the main flame and/or pilot goes out.
  - f. R7140L goes to Safety Shutdown; R7140G, M recycle after 15-second postpurge.
  - g. Safety shutdown occurs. (R7140L only.)
7. Opening a Preignition Interlock after the first five seconds of POSTPURGE.
  - a. Open the main fuel manual shutoff valve(s) and open manual pilot shutoff valve(s).
  - b. Depress the reset button.
  - c. \*Preignition ILK\* fault is displayed on the Keyboard Display Module. Fault code 33 is displayed to denote the fault.
  - d. Safety shutdown occurs.

### IMPORTANT

1. If the relay module fails to shut down on any of these tests, take corrective action; refer to Troubleshooting and the relay module diagnostics and return to the beginning of all Checkout tests.
2. When all Checkout tests are completed, reset all switches to the original status.