

REGULATORS BALANCED ZERO

for 150° F Service Pyronics® Model BZR

MODEL: 5101 - BZR

Revision: 1

BULLETIN
5101

Sensitive and accurate, the Pyronics BZR regulator delivers gas at a precise pressure, even with slight inlet pressure variations.

The Pyronics BZR regulator is designed for ambient temperatures up to a continuous operating range of 150° F. For precise control of heated gases or higher ambient operating conditions, Models BZR-300, BZR-500 and BZR-700 are available.

Balanced Zero Regulators feature a rugged, large diaphragm actuated valve assembly, sensitively balanced at near zero pressure. Gas flow is initiated by a very small pressure differential across the main diaphragm. Gas supply is precisely modulated on system demand by negative or positive signals from suction mixers or controlled pressure from an external source.

The BZR regulator assures dependable, precise gas flow control on all types of combustion systems including proportioning premixers, nozzle mixers and mixing tees at positive or negative combustion chamber pressures.

NOTE: Now available in a smaller 1/2" pipe size.



CAPACITY TABLE

Model Number	Pipe Size		SCFH Gas Flow @ 4.0" W.C. Pressure Drop			
	Inlet	Outlet	MFD. 0.4 Sp. Gr.	NAT. 0.6 Sp. Gr.	AIR 1.0 Sp. Gr.	L.P. 1.5 Sp. Gr.
4 - BZR	1/2"	1/2"	550	450	350	280
6 - BZR	3/4"	3/4"	790	650	500	410
8 - BZR	1"	1"	1,580	1,290	1,000	820
12 - BZR	1-1/2"	1-1/2"	3,160	2,580	2,000	1,640
16 - BZR	2"	2"	5,530	4,520	3,500	2,860
20 - BZR	2-1/2"	2-1/2"	7,900	6,450	5,000	4,100
24 - BZR	3"	3"	12,600	10,300	8,000	6,500
32 - BZR	4"	4"	22,100	18,100	14,000	11,400

FEATURES

- Accuracy:
 - Low - Flow: ± 0.1 " W.C.
 - Full - Flow: ± 0.3 " W.C.
- Turndown up to 200:1
- Operating temperatures to 150 °F
- All units factory tested and sealed before shipment
- Maximum inlet pressure: 2.0 psig
- Maximum pressure differential: 14.0" W.C.



CAUTION: Operation of combustion equipment can be hazardous resulting in bodily injury or equipment damage. Each burner should be supervised by a combustion safeguard and only qualified personnel should install, make system adjustments and perform any required service.



PYRONICS
A Selas Heat Technology Brand

130 Keystone Drive
Montgomeryville, PA 18936-8375
www.selas.com

Phone: +1 215-646-6600
Fax: +1 215-646-3536
E-mail: sales@selas.com

NOTICE: PYRONICS practices a policy of continuous improvement in the design of its products. It reserves the right to change the specifications at any time without prior notice.

REGULATORS BALANCED ZERO

BULLETIN 5101
PAGE NO. 2

DIMENSIONS: 1/2" - 3" SIZES

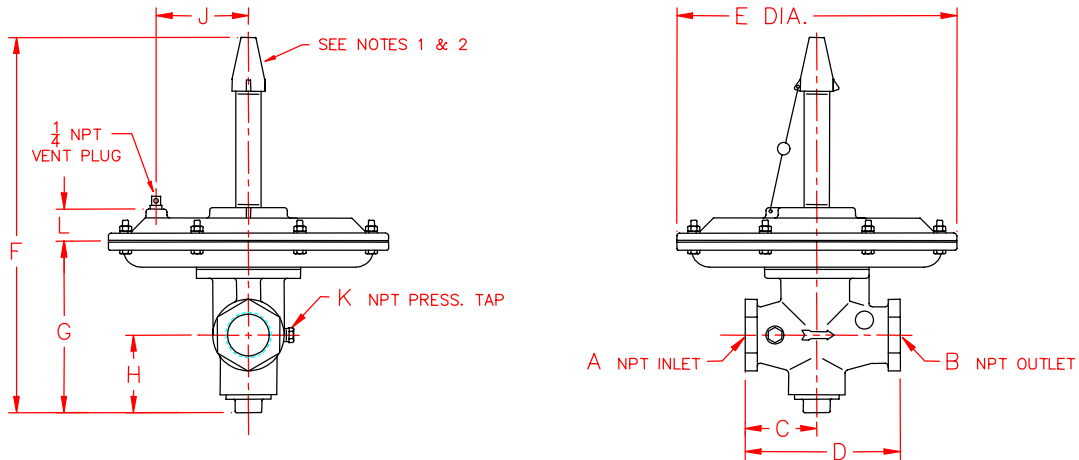

Model Number	A	B	C	D	E	F	G	H	J	K	L	Weight Lbs.
4 - BZR	1/2	1/2	1-3/4	3-3/4	7	8-3/4	3-1/2	1-3/4	2-1/8	---	1	3.1
6 - BZR	3/4	3/4	2-1/2	5	8-1/4	11-1/4	4-7/8	2	2-3/4	1/8	1-1/4	6.5
8 - BZR	1	1	2-3/8	4-3/4	9-3/4	11-3/4	4-3/4	2	3-3/8	1/8	1-1/4	8.5
12 - BZR	1-1/2	1-1/2	3	6-1/2	11-3/4	15-3/4	7-1/4	3-1/4	3-7/8	1/4	1-3/8	15.5
16 - BZR	2	2	3-1/2	7-1/2	11-3/4	16-1/8	8-1/8	3-7/8	3-7/8	1/4	1-3/8	20.0
20 - BZR	2-1/2	2-1/2	4	8-3/4	14	17-5/8	8-3/4	3-5/8	3-5/8	1/4	1-7/8	50.0
24 - BZR	3	3	5-3/4	11-1/2	14	20-3/8	10-5/8	4-5/8	3-5/8	1/4	1-7/8	60.5

DIMENSIONS: 4" SIZE

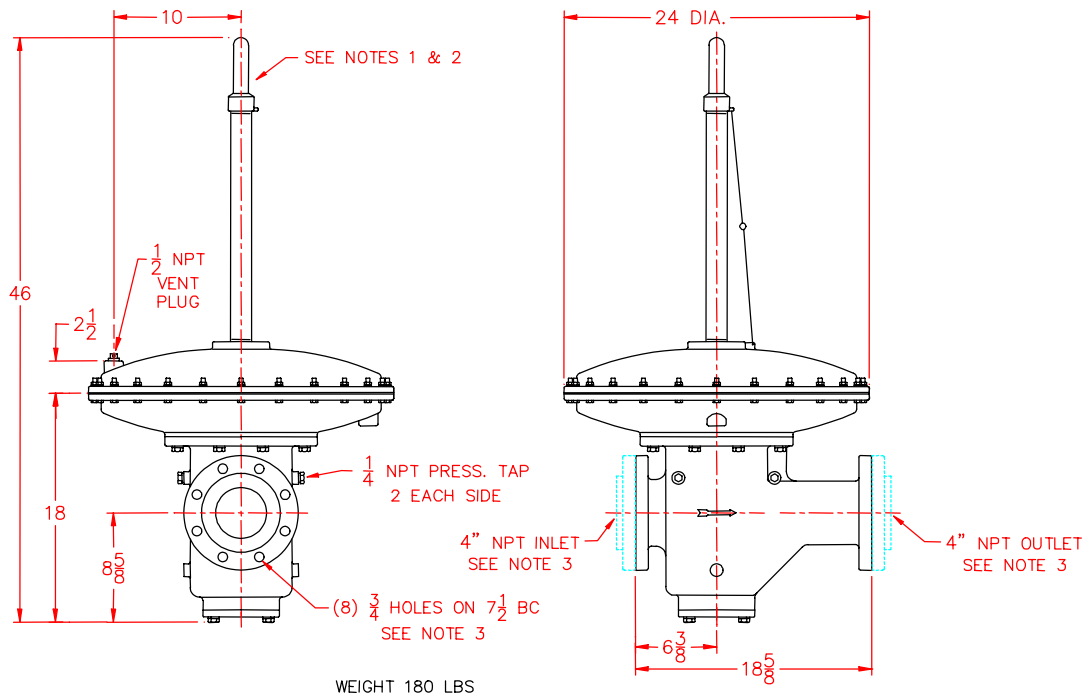

WEIGHT 180 LBS

NOTES:

- | | |
|--|---|
| <ol style="list-style-type: none"> 1. Spring housing must be perpendicular to pipe run in an upright position. 2. Gas pipe run must be horizontal and level. | <ol style="list-style-type: none"> 3. Designed to accept standard 4" ANSI flanges. 4. All dimensions are in inches. |
|--|---|

ORDERING INFORMATION

- | | |
|--|--|
| <ol style="list-style-type: none"> 1. Specify Inlet and Outlet Pressure. 2. Type of Gas, Flow, Specific Gravity and Temperature. | <ol style="list-style-type: none"> 3. Specify Model Number and Quantity. 4. Shipping Instructions. |
|--|--|