

RV SERIES

Straight-Thru-Flow Design

Maxitrol's original straight-thru-flow (STF) design regulators are non-lockup type regulators for high capacities at low inlet pressures. The difference between STF design and other type regulators is the conical valve. The cone principal permits gas to flow straight through the regulator without changing directions. Frictional flow resistance is reduced, resulting in greater capacity. An improved flow pattern provides accurate, sensitive regulation at extremely low pressure differentials. Typical applications include residential, commercial, and industrial gas-fired appliances and equipment used on low or medium pressure gas supplies.



RV81

Specifications

- Pipe Sizes** 1/2" to 3" threaded connections with NPT or ISO7-1 threads. 4" 150lb. flange (RV131 only).
- Housing Material** RV52, RV53, RV61, RV81, RV91, RV111: aluminum; RV131: cast iron.
- Mounting** RV52, RV53, RV61 are suitable for multi-positional mounting. If ball check vent limiting device is installed, mount in an upright position only. RV81, RV91, RV111, RV131, upright position only.
NOTE: All Maxitrol gas pressure regulators should be installed and operated in accordance with Maxitrol Safety Warning Instructions (see GPR_MI_EN.ES or GPR_CSA_MI_EN.FR).
- Certifications** RV52, RV53, RV61, RV81, RV91, RV111: ANSI Z21.18/CSA6.3 Gas Appliance Pressure Regulators.
- Gas Types** Suitable for natural, manufactured, mixed gases, liquefied petroleum gases, and LP gas-air mixtures.
- Maximum Inlet Pressure** CSA Certified: RV52, RV53, RV61, RV81, RV91, RV111: 1/2 psi (3.4 kPa)
 Maxitrol Tested*: RV52, RV53: 1/2 psi (3.4 kPa)
 RV61, RV81, RV91, RV111: 1 psi (6.9 kPa)
 RV131: 2 psi (13.8 kPa)
- *Do not use if inlet pressure is more than 10 times desired outlet pressure.
- Emergency Exposure Limits**..... RV52, RV53: 3 psi (21 kPa)
 RV61, RV81, RV91, RV111: 5 psi (34 kPa)
 RV131: 15 psi (103 kPa)
- Gas Containment Limits**..... RV52, RV53: 15 psi (103 kPa)
 RV61, RV81, RV91, RV111, RV131: 25 psi (172 kPa)
NOTE: Internal damage may occur when exposed to these pressures.
- Ambient Temperature Ranges**... RV52, RV53, RV61, RV81, RV91, RV111: -40° to 205°F (-40° to 96°C)
 RV131: -40° to 125°F (-40° to 52°C)
- Minimum Regulation**..... RV52, RV53: 20 CFH; RV61: 25 CFH; RV81, RV91: 50 CFH; RV111, RV131: 250 CFH.
 Expressed in CFH @ 0.64 sp gr gas.



Capacities and Pressure Drop

Capacities expressed in CFH (m³/h) @ 0.64 sp gr gas

Model	Pipe Size	CSA MAX	Pressure Drop - inches w.c. (kPa)												
			0.1 (0.02)	0.2 (0.04)	0.3 (0.07)	0.4 (0.10)	0.5 (0.12)	0.6 (0.15)	0.7 (0.17)	0.8 (0.20)	0.9 (0.22)	1.0 (0.25)	2.0 (0.5)	3.0 (0.75)	4.0 (1.0)
RV52	1/2" x 1/2" 3/4" x 3/4"	450 (12.7)	151 (4.2)	214 (6.1)	262 (7.4)	302 (8.5)	338 (9.5)	370 (10.5)	400 (11.3)	427 (12.1)	453 (12.8)	478 (13.5)	676 (19.1)	828 (23.4)	956 (27.1)
RV53	3/4" x 3/4" 1" x 1"	690 (19.5)	217 (6.1)	306 (8.6)	375 (10.6)	433 (12.2)	484 (13.7)	530 (15)	573 (16.2)	612 (17.3)	650 (18.4)	684 (19.3)	968 (27.4)	1185 (33.5)	1369 (38.7)
RV61	1" x 1" 1 1/4" x 1 1/4"	900 (24.5)	379 (10.7)	536 (15.1)	675 (19.1)	759 (21.5)	848 (24.0)	929 (26.3)	1004 (28.4)	1073 (30.4)	1138 (32.2)	1200 (34.0)	1742 (49.3)	2134 (60.4)	2464 (69.8)
RV81	1 1/4" x 1 1/4" 1 1/2" x 1 1/2"	2500 (70.8)	780 (22.1)	1102 (31.2)	1350 (38.2)	1559 (44.1)	1743 (49.5)	1909 (54.0)	2062 (58.4)	2204 (62.4)	2339 (66.2)	2465 (69.8)	3485 (98.7)	4269 (120)	4929 (139)
RV91	2" x 2" 2 1/2" x 2 1/2"	3275 (92.7)	1212 (34.3)	1714 (48.5)	2100 (59.4)	2424 (68.6)	2711 (76.7)	2969 (84.1)	3208 (90.8)	3429 (97.1)	3637 (103)	3834 (108)	5422 (153)	6640 (188)	7668 (217)
RV111	2 1/2" x 2 1/2" 3" x 3"	7500 (212)	2742 (78.0)	3878 (110)	4750 (134)	5485 (155)	6132 (175)	6718 (190)	7256 (205)	7757 (219)	8227 (233)	8572 (243)	12134 (343)	14862 (420)	17161 (486)
RV131	4" x 4"	---	4734 (134)	6695 (190)	8200 (232)	9468 (268)	10586 (300)	11596 (328)	12525 (354)	13390 (380)	14202 (402)	14971 (424)	21172 (600)	25930 (734)	29942 (848)

NOTE: See pages 58-59 for Regulator Sizing Requirements and Examples.

Spring Selection Chart: inches w.c. (kPa)

Model	CSA Certified Springs			Other Springs Available								
	3 to 6 (0.75 to 1.5) Plated	4 to 8 (1 to 2) Orange	5 to 12 (1.25 to 3) Blue	1 to 3.5 (0.25 to 0.9) Brown	2 to 5 (0.5 to 1.25) Plated	3 to 8 (0.75 to 2) Pink	4 to 12 (1 to 3) Violet	---	---	10 to 22 (2.5 to 5.5) Red	---	---
RV52	3 to 6 (0.75 to 1.5) Plated	4 to 8 (1 to 2) Orange	5 to 12 (1.25 to 3) Blue	1 to 3.5 (0.25 to 0.9) Brown	2 to 5 (0.5 to 1.25) Plated	3 to 8 (0.75 to 2) Pink	4 to 12 (1 to 3) Violet	---	---	---	---	---
RV53	3 to 6 (0.75 to 1.5) Plated	4 to 8 (1 to 2) Orange	5 to 12 (1.25 to 3) Blue	1 to 3.5 (0.25 to 0.9) Brown	2 to 5 (0.5 to 1.25) Plated	3 to 8 (0.75 to 2) Pink	4 to 12 (1 to 3) Violet	---	---	---	---	---
RV61	3 to 6 (0.75 to 1.5) Plated	4 to 8 (1 to 2) Orange	5 to 12 (1.25 to 3) Blue	1 to 3.5 (0.25 to 0.9) Brown	2 to 5* (0.5 to 1.25) Plated	3 to 8 (0.75 to 2) Pink	---	---	10 to 22 (2.5 to 5.5) Red	---	---	---
RV81	3 to 6 (0.75 to 1.5) Plated	4 to 8 (1 to 2) Orange	5 to 12 (1.25 to 3) Blue	1 to 3.5 (0.25 to 0.9) Brown	2 to 5 (0.5 to 1.25) Plated	3 to 8 (0.75 to 2) Pink	4 to 12 (1 to 3) Violet	5 to 15 (1.25 to 3.7) Green	10 to 22 (2.5 to 5.5) Red	---	---	---
RV91	3 to 6 (0.75 to 1.5) Plated	4 to 8 (1 to 2) Orange	5 to 12 (1.25 to 3) Blue	1 to 3.5 (0.25 to 0.9) Brown	2 to 5 (0.5 to 1.25) Plated	3 to 8 (0.75 to 2) Pink	4 to 12 (1 to 3) Violet	5 to 15 (1.25 to 3.7) Green	10 to 22 (2.5 to 5.5) Red	---	---	---
RV111	3 to 6 (0.75 to 1.5) Plated	4 to 8 (1 to 2) Orange	5 to 12 (1.25 to 3) Blue	1 to 3.5 (0.25 to 0.9) Brown	2 to 5 (0.5 to 1.25) Plated	3 to 8 (0.75 to 2) Pink	4 to 12 (1 to 3) Violet	5 to 15 (1.25 to 3.7) Green	10 to 22 (2.5 to 5.5) Red	---	---	---
RV131	3 to 6 (0.75 to 1.5) Plated	---	5 to 12 (1.25 to 3) Blue	---	2 to 5 (0.5 to 1.25) Plated	3 to 8 (0.75 to 2) Pink	4 to 12 (1 to 3) Violet	---	10 to 22 (2.5 to 5.5) Red	15 to 30 (3.7 to 7.5) Yellow	20 to 42 (5 to 10.5) Black	---

NOTE: The area within the heavy line indicates CSA certified springs. See pages 56-57 for complete Spring Selection Chart.

* The 2 to 5 inches w.c. (0.5 to 1.25 kPa) spring is also CSA certified for the RV61

RV SERIES

Straight-Thru-Flow Design

Dimensions

Model	Pipe Size	Vent Connection	Swing Radius	Dimensions			
				A	B	C	D
RV52	1/2", 3/4"	1/8" NPT	3.6" (91 mm)	4.9" (124 mm)	3.2" (81 mm)	3.3" (83 mm)	1.3" (32 mm)
RV53	3/4", 1"	1/8" NPT	3.9" (99 mm)	5.2" (132 mm)	3.8" (95 mm)	3.9" (99 mm)	1.3" (33 mm)
RV61	1", 1 1/4"	1/8" NPT	4.8" (122 mm)	6.4" (164 mm)	4.4" (111 mm)	5.4" (138 mm)	1.6" (41 mm)
RV91	2"	1/2" NPT	8.5" (216 mm)	10.8" (275 mm)	6.5" (165 mm)	9.1" (232 mm)	2.3" (60 mm)
	2 1/2"	1/4" NPT	8.3" (212 mm)	10.5" (267 mm)	7.1" (181 mm)	9.1" (232 mm)	2.4" (62 mm)
RV111	2 1/2", 3"	3/4" NPT	11.5" (284 mm)	15.1" (373 mm)	9" (229 mm)	13.4" (324 mm)	3.5" (89 mm)
RV131	4"	3/4" NPT	18.2" (462 mm)	23.3" (592 mm)	13.9" (353 mm)	18" (457 mm)	5.1" (130 mm)

NOTE: Dimensions are maximums and to be used only as an aid in designing clearance for the valve. Actual production dimensions may vary somewhat from those shown.

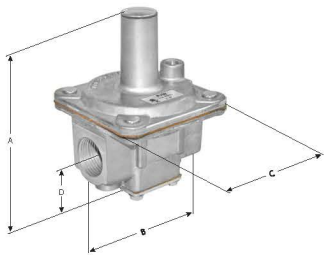

RV52, RV53

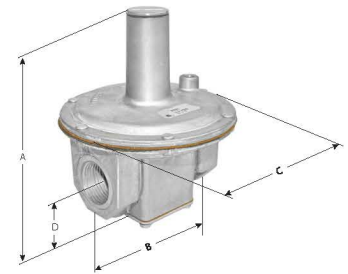

RV61

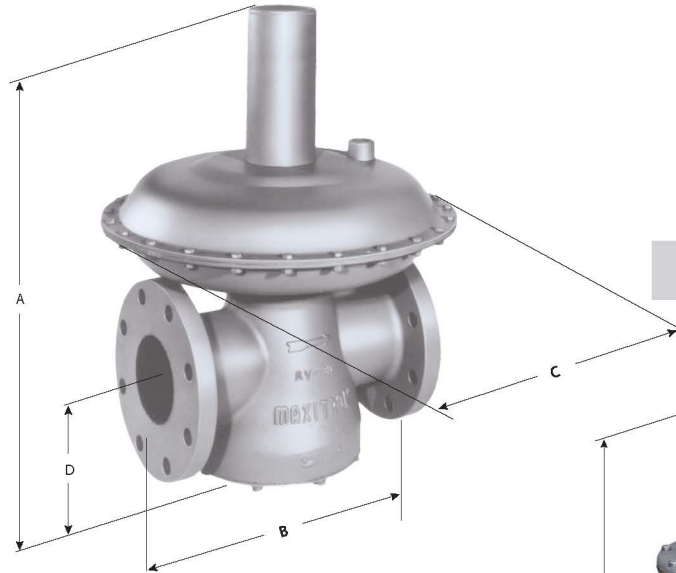

RV131

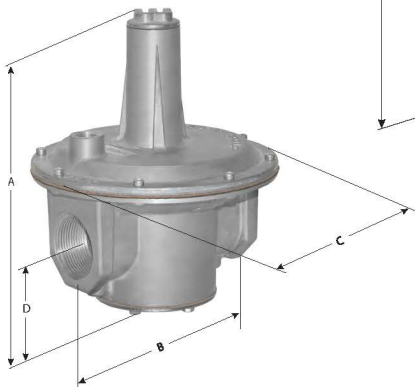

RV81, RV91

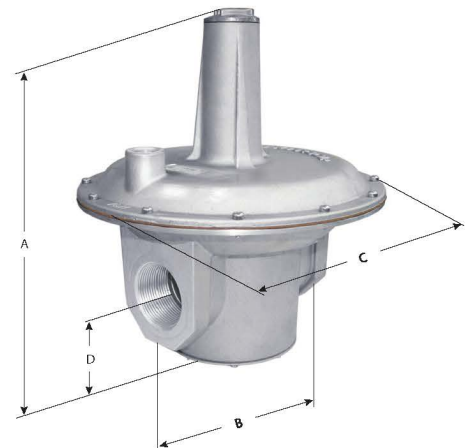

RV111

Straight-Thru-Flow Design

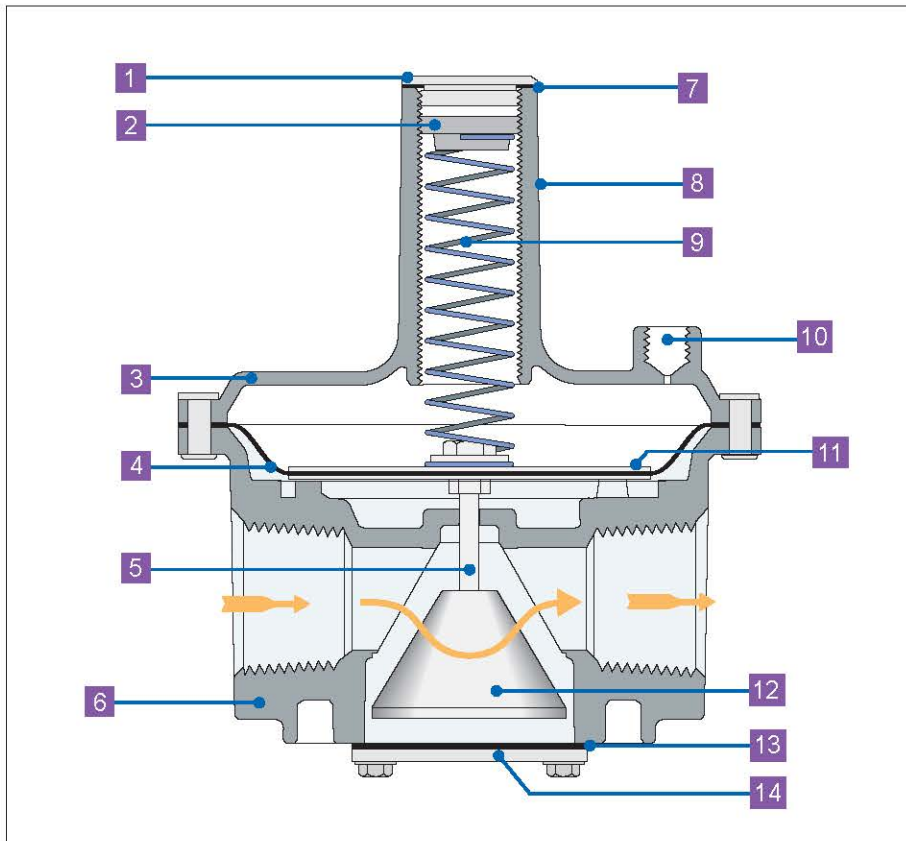

- 1 Welch Plug/Seal Cap
- 2 Vibration Resistant Adjusting Screw
- 3 Top Housing
- 4 Diaphragm
- 5 Stem
- 6 Bottom Housing
- 7 Seal Cap Gasket
- 8 Stack
- 9 Spring
- 10 Vent Connection
- 11 Diaphragm Plates
- 12 Valve
- 13 Bottom Plate Gasket
- 14 Bottom Plate

NOTE: Diagrams are graphical representations only and may differ from actual product.