

# SR100 Series Service Regulators

## Instruction Manual



# SR100 Series Service Regulators

## General Information

The SR113 Service Regulator comes equipped with a full capacity internal relief valve and features a 3/4" or 1" NPT threaded vent.

Available 180° valve body sizes: 3/4" x 3/4", 3/4" x 1" and 1" x 1" NPT or BSP-TR.

Available 90° valve body sizes: 3/4" x 3/4", 3/4" x 1" and 1" x 1" NPT or BSP-TR.

Offset valve body sizes: 3/4" x 3/4", 3/4" x 1" and 1" x 1" NPT or BSP-TR.

## Regulator Pressure Ratings



To prevent regulator damage and possible personal injury, pressures must not exceed:

Maximum inlet pressure, normal service ( $P_1$ ): Depending on orifice size, up to 125 PSIG (see Table 3 on page 4).

Maximum outlet pressure, normal service ( $P_2$ ): Depending on spring selection, up to 2 PSIG (see Table 1 on page 3).

Maximum inlet pressure for abnormal or emergency service without causing damage to regulator case is 175 PSIG.

Maximum outlet pressure which can be contained by pressure carrying components (no flange leakage to atmosphere except for normal relief action) is 10 PSIG. Remove from service if regulator is subjected to this condition.

Maximum outlet pressure for abnormal service without damage to internal components is 50 PSIG. Remove from service if regulator is subjected to this condition.

## Applications

Model Number	Description
SR113	Basic regulator, full-capacity internal relief with 3/4" or 1" NPT vent.

## Preparations



Do not connect the inlet of the regulator to a pressure source higher than recommended in Table 3 on page 4. Never connect the regulator outlet to the pressure source. Observe the flow direction arrow on the valve body. Some additional form of overpressure protection may be required in applications where downstream maximum pressure ratings are less than the regulator inlet pressure.

Install, operate, inspect and maintain the regulators as outlined in the following instructions and in accordance with your company's policies and applicable federal, state, and local codes and laws. Failure to follow these instructions may result in damage to the regulator or personal injury.

1. Check installation location for suitability. Physical changes may have been made to the building site since the original installation.
2. Examine regulator for shipping damage.
3. Check regulator and piping for foreign matter which may have accumulated during shipment or handling.

4. Check regulator information stamped on seal plug to determine if regulator is suitable for intended service (see Item 14, page 3).
5. Suitable stop valve(s) should be installed and conveniently located.
6. Filters are available from Elster American Meter for applications where pipeline contaminants are believed to be present.
7. Regulators may be used at temperatures between -20°F and +150°F (-30°C and +65°C).

Figure 1

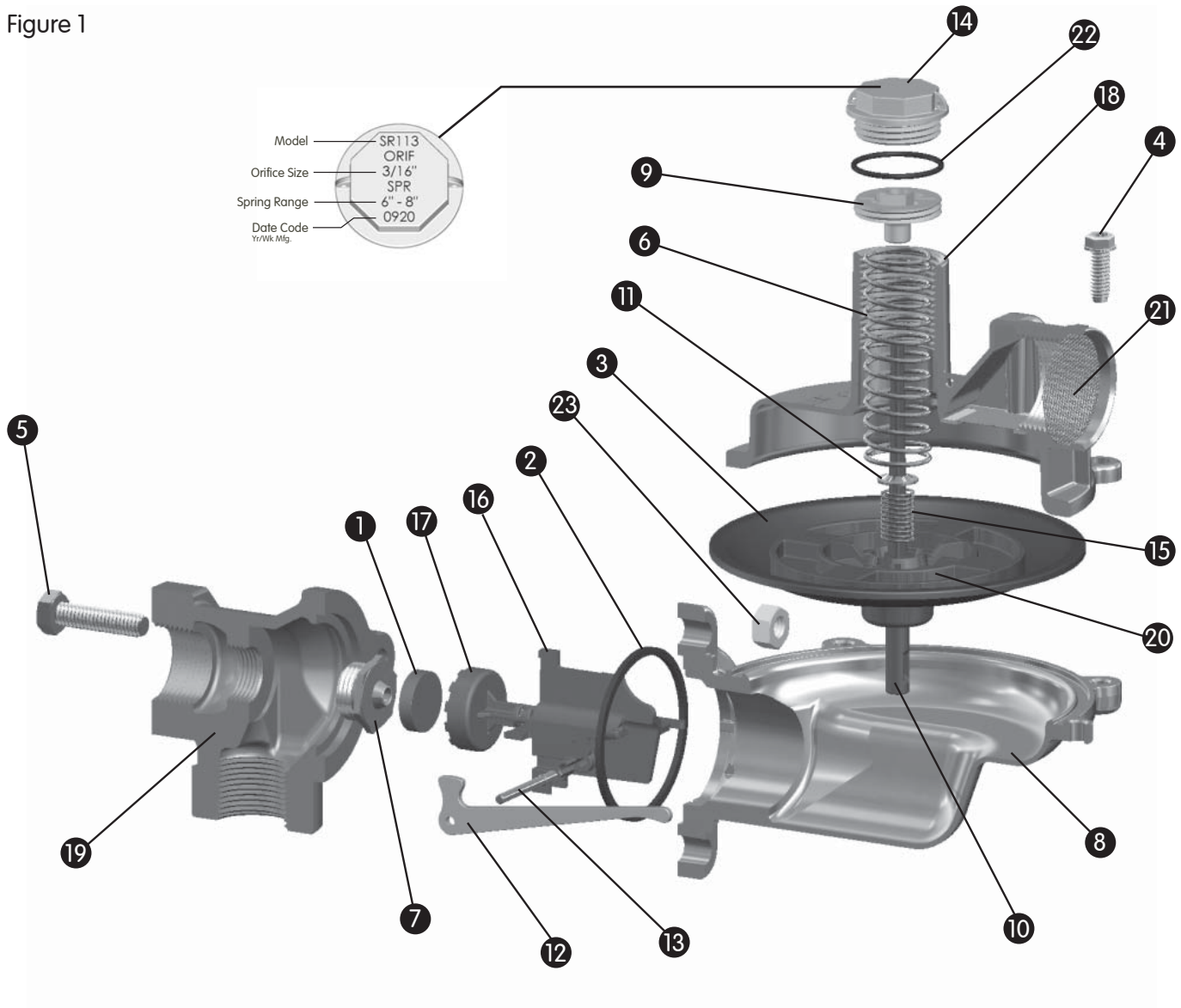

- 1 Disc, Valve Seat
- 2 Seal Ring, Valve Body
- 3 Diaphragm
- 4 Screw, Diaphragm Case
- 5 Bolt, Valve Body
- 6 Spring, Pressure (Table 1)
- 7 Valve, Orifice (Table 2)
- 8 Diaphragm Case
- 9 Screw, Pressure Adjustment
- 10 Stem, Relief Valve
- 11 Retainer, Relief Valve Spring
- 12 Lever
- 13 Pin, Lever
- 14 Plug, Seal
- 15 Spring, Relief Valve
- 16 Guide, Valve Plunger
- 17 Plunger, Valve
- 18 Assembly, Top
- 19 Valve, Body
- 20 Plate, Diaphragm
- 21 Screen, Vent
- 22 Gasket, Seal Plug
- 23 Nut, Valve Body

Table 1  
Pressure Spring

Outlet Pressure	Color Code	Part Number
6" to 8" W.C.	Blue/Yellow	70017P138
7" to 12" W.C.	Blue/Red	70017P139
13" to 16" W.C.	Blue/White	70017P140
21" to 35 W.C.	Blue/Orange	70017P141
2 PSIG	White	70017P060

Table 2  
Orifice

Orifice Size	Standard Part Number
5/16"	72494P022
1/4"	72494P021
3/16"	72494P020
1/8" x 3/16"	72494P030

## Installation



**Inside Installation:** A vent line of sufficient diameter to carry gas vented by the regulator to a safe outside location away from any opening in the building is required. For all sizes of regulators, a 3/4" or 1" threaded vent is provided for a vent line. Verify vent piping does not interfere with the vent flapper movement.

**Outside Installation:** Care must be taken to prevent vent opening from freezing closed, becoming blocked, or allowing water to enter from any cause. Particular consideration should be given to sites where flooding, snow, or freezing rain may be experienced. The vent or vent line port should point vertically downward, and overhead protection should be used where necessary.

(Numbers in parentheses refer to Figure 2.)

1. Remove all shipping plugs from the valve body.
2. Use good piping practice. Be sure piping and regulator are free of dirt, pipe dope and other debris. Apply pipe dope to male threads only.
3. Install regulator. Make certain it is installed correctly with inlet pipe connected to the inlet regulator connection and flow is in the direction as indicated by arrow located on valve body (1). Elster American Meter suggests the vent point downward to prevent entry of water and debris. By removing the two valve body bolts (2), the diaphragm case (3) may be rotated in 90-degree increments in relation to the valve body (1). Replace and tighten the two valve body bolts (2) to 100 ±25 in. lbs. A regulator installed within a building should be located as near as practical to the point of service line entrance.
4. Make sure inlet pressure is always less than the maximum recommended inlet pressure for the orifice size (see Table 3). Turn gas on slowly. If an outlet valve is used, it should be opened first. Do not subject the regulator to a sudden surge of inlet pressure.
5. Assure that there are no leaks and all connections are tight.
6. The SR100 Series regulator is preset at the factory. Should you decide to adjust the set pressure, perform the following:
  - a. Turn gas off and depressurize the system.
  - b. Install outlet pressure gauge.
  - c. Turn gas on slowly.
  - d. Establish a low flow rate between 45 and 55 SCFH.
  - e. Remove seal plug (4) with a 1" wrench.
  - f. Turn pressure spring adjustment screw (5) clockwise to

increase outlet pressure; counterclockwise to decrease outlet pressure.

- g. Establish the outlet pressure within the range limits of the pressure spring used.
- h. To test for the regulator's ability to fully shut off (lock-up), shut off all flow downstream of the regulator. At lock-up, the outlet pressure will be somewhat higher than the set pressure. However, if the pressure continues to rise after 3 seconds, the regulator must be repaired. Observe for 30 seconds.
- i. When the set pressure is properly adjusted, depressurize and remove gauge(s) and lines.
- j. Replace seal plug (4).
- k. Pressurize and check all connections for leaks.

Figure 2

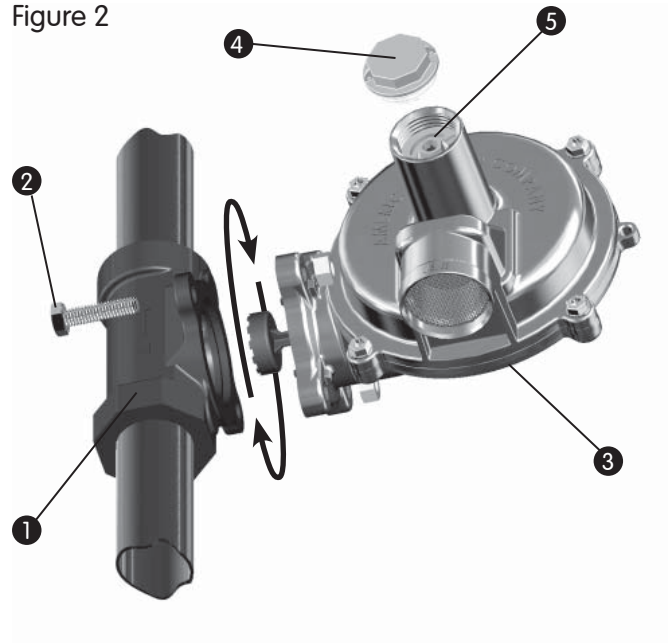

Table 3

### Maximum Recommended Inlet Pressure

Orifice Size	Inlet Pressure (PSIG)
1/8" x 3/16"	125
3/16"	125
1/4"	125
5/16"	100

This is the maximum inlet the regulator should operate at to insure complete lockup at no-flow conditions.

## Inspection



Regulators are pressure-control mechanisms having numerous moving parts which can wear. In addition, regulator damage may occur from external sources. For these reasons, the regulator should be periodically inspected and checked for proper operation. The frequency of inspection depends on the severity of the service conditions and the requirements of applicable local, state, and federal codes and regulations.

Follow the procedure below for field inspection of the orifice and seat disc. Repair parts are available through Elster American Meter if parts are worn or damaged. Exercise care to prevent foreign material from entering the regulator during any inspection or maintenance activities.

### Inspection of Valve Seat Disc and Orifice

(Numbers in parentheses refer to Figure 3.)

1. Shut off gas supply and depressurize the system.
2. Remove two valve body bolts (2) securing the diaphragm case (3) to the valve body (1) with a 1/2" wrench. Separate the diaphragm case from the valve body.
3. Visually check the seating edge of the orifice inside the valve body (1). If it is nicked or damaged, it should be replaced with a new orifice to provide positive shut off. See Maintenance instructions for replacing orifice on page 6.
4. Inspect the surface of the valve seat disc (4). If it is scored or uneven, replace it as outlined in the Maintenance instructions for replacing the seat disc on page 5.
5. Install new seal ring (5) in the diaphragm case groove.
6. Inspect unit for cleanliness and proper positioning of the parts. Pay particular attention to the proper positioning of the seal ring (5) in the groove.
7. Install the diaphragm case (3) on the valve body (1). Make sure the vent is positioned so that it cannot become plugged or allow water to enter. Replace and tighten the two valve body bolts (2) to 100 ±25 in. lbs.
8. Proceed to Steps 4, 5 and 6 of the Installation instructions.

## Maintenance



As a knowledgeable user of Elster American Meter Company products, you should be aware that parts in the Company's meters and regulators contain, or are coated with, heavy metals such as cadmium, zinc, lead and chromium. Repair or refurbishment of this equipment should take into account the presence of these materials and should comply with all state and federal requirements concerning worker protection, proper disposal, and safety including protection against exposure to dust and fumes.

### Replacing Seat Disc

(Numbers in parentheses refer to Figure 3.)

1. Follow steps 1 and 2 of the Inspection instructions on page 5 to access seat disc.
2. Carefully insert the tip of a knife along the edge of the seat disc (4) and lift the seat disc out of the plunger (6).
3. Install a new seat disc (4) into the plunger (6) by pressing into place. Make sure that the disc is pressed completely into the plunger (6).
4. Proceed to Steps 5, 6, 7, and 8 of the Inspection instructions on page 5.

Figure 3

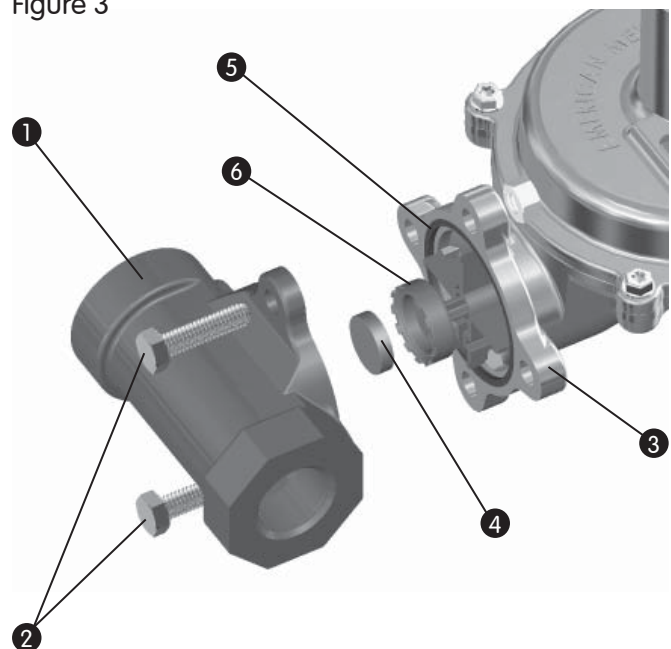

## Maintenance



Regulators that have an orifice size different than shown on the seal plug tag must have their set pressure reestablished. Mark the new orifice size on the regulator seal plug or on its tag.

### Replacing the Orifice

(Numbers in parentheses refer to Figure 4.)

1. Shut off gas supply and depressurize the system.
2. Remove the two valve body bolts (2) securing the diaphragm case (3) to the valve body (1) with a 1/2" wrench. Place the diaphragm case aside and protect the seat disc (5) from dirt particles and physical damage.
3. Remove the orifice valve (4) with a 7/8" hex socket wrench.
4. Sparingly apply Henkell G30 or Loctite "Stainless Steel PST" thread sealant or equivalent (not supplied) to the new orifice threads.
5. Carefully start the threads of the orifice into the valve body and tighten to  $350 \pm 50$  in lbs. Care must be taken to prevent nicking the orifice.
6. Proceed to Steps 5, 6, 7 and 8 of the Inspection instructions on page 5.

Figure 4

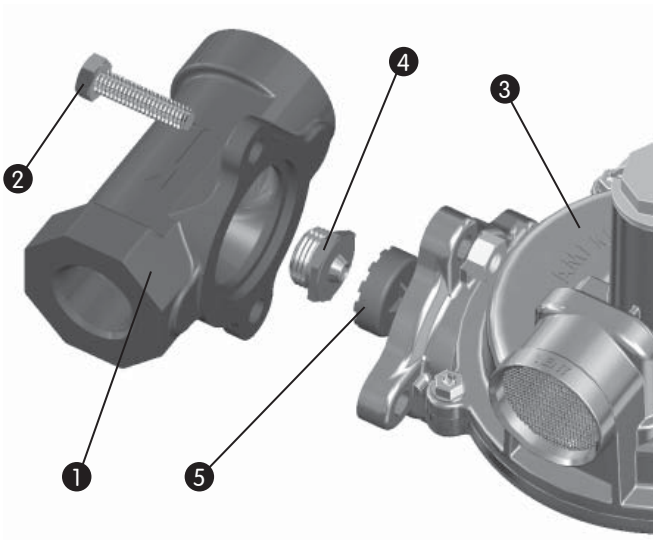

## Maintenance



Regulators that have a pressure spring removed or replaced must have their set pressure reestablished. If the pressure spring is different from that shown on the seal plug or tag, mark the new spring range on the regulator seal plug or on its tag.

### Replacing the Pressure Spring

(Numbers in parentheses refer to Figure 5.)

1. Shut off gas supply and depressurize the system.
2. Remove seal plug (1) with a 1" wrench.
3. Unscrew pressure adjusting screw (2) with a 3/8" nut driver. Completely remove the pressure adjusting screw (2).
4. Remove the pressure spring (3). Install new pressure spring.
5. Replace the pressure adjusting screw and turn adjusting screw to about mid position.
6. Proceed to Steps 4, 5, and 6 of the Installation instructions on page 4 to set delivery pressure.

Figure 5

