

English – April 2017

Introduction

This installation guide provides instructions for installation, startup and adjustment. To receive a copy of the instruction manual, contact your local Sales Office or view a copy at www.fisher.com. For further information refer to: 67D Series Instruction Manual, form 5858, D103151X012.

P.E.D. Category

This product may be used as a safety accessory with pressure equipment in the following Pressure Equipment Directive categories. It may also be used outside of the Pressure Equipment Directive using sound engineering practice (SEP) per table below. For information on the current PED revision see Bulletin: [D103053X012](#).

PRODUCT SIZE	CATEGORIES	FLUID TYPE
1/2 NPT	SEP	1

Specifications

Body Size and End Connection Style

1/2 NPT

Maximum Inlet Pressure (Body Rating)⁽¹⁾

Filtered models: 17.2 bar / 250 psig

Unfiltered models: 27.6 bar / 400 psig

Maximum Emergency Outlet Pressure⁽¹⁾

10.3 bar / 150 psig over outlet pressure setting up to a maximum of 17.2 bar / 250 psig

Proof Test Pressure

All Pressure Retaining Components have been proof tested per Directive.

Outlet Pressure Ranges⁽¹⁾

0 to 1.4 bar / 0 to 20 psig

0 to 2.4 bar / 0 to 35 psig

0 to 4.1 bar / 0 to 60 psig

0 to 8.6 bar / 0 to 125 psig

0 to 10.3 bar / 0 to 150 psig

Temperature Capabilities⁽¹⁾

With Nitrile (NBR)

Standard Bolting: -29 to 82°C / -20 to 180°F

Stainless Steel Bolting: -40 to 82°C / -40 to 180°F

With Fluorocarbon (FKM)

Polyethylene Filter⁽²⁾ (standard): -18 to 82°C / 0 to 180°F

Polyvinylidene (PVDF), Stainless Steel or Glass Filter (Optional): -18 to 149°C / 0 to 300°F

Temperature Capabilities⁽¹⁾ (continued)

With Silicone (VMQ)⁽³⁾ Diaphragm, Low Temperature Nitrile (NBR) O-rings and Low Temperature Bolting: -51 to 82°C / -60 to 180°F

With Gauges: -29 to 82°C / -20 to 180°F

With Automatic Drain: 4 to 79°C / 40 to 175°F

Installation



WARNING

Only qualified personnel should install or service a regulator. Regulators should be installed, operated and maintained in accordance with international and applicable codes and regulations and Emerson Process Management Regulator Technologies, Inc. instructions.

If the regulator vents fluid or a leak develops in the system, it indicates that service is required. Failure to take the regulator out of service immediately may create a hazardous condition.

Personal injury, equipment damage or leakage due to escaping fluid or bursting of pressure-containing parts may result if this regulator is overpressured or is installed where service conditions could exceed the limits given in the Specifications section or where conditions exceed any ratings of the adjacent piping or piping connections.

To avoid such injury or damage, provide pressure-relieving or pressure-limiting devices (as required by the appropriate code, regulation or standard) to prevent service conditions from exceeding limits.

Additionally, physical damage to the regulator could result in personal injury and property damage due to escaping fluid. To avoid such injury and damage, install the regulator in a safe location.

The internal relief valve in the Types 67DFR and 67DFSR regulators do not provide full overpressure protection. The internal relief valve is designed for minor seat leakage only.

1. The pressure/temperature limits in this Installation Guide and any applicable standard or code limitation should not be exceeded.

2. Do not use in high aromatic hydrocarbon service.

3. Silicone (VMQ) is not compatible with hydrocarbon gas.

67D Series

Clean out all pipelines before installation of the regulator and check to be sure the regulator has not been damaged or has collected foreign material during shipping. For NPT bodies, apply pipe compound to the external pipe threads. For flanged bodies, use suitable line gaskets and approved piping and bolting practices. Install the regulator in any position desired, unless otherwise specified, but be sure flow through the body is in the direction indicated by the arrow on the body.

Note

It is important that the regulator be installed so that the vent hole in the spring case is unobstructed at all times. For outdoor installations, the regulator should be located away from vehicular traffic and positioned so that water, ice and other foreign materials cannot enter the spring case through the vent. Avoid placing the regulator beneath eaves or downspouts and be sure it is above the probable snow level.

Overpressure Protection

The recommended pressure limitations are stamped on the regulator nameplate. Some type of overpressure protection is needed if the actual inlet pressure exceeds the maximum operating outlet pressure rating. Overpressure protection should also be provided if the regulator inlet pressure is greater than the safe working pressure of the downstream equipment.

Regulator operation below the maximum pressure limitations does not preclude the possibility of damage from external sources or debris in the line. The regulator should be inspected for damage after any overpressure condition.

Startup

The regulator is factory set at approximately the midpoint of the spring range or the pressure requested, so an initial adjustment may be required to give the desired results. With proper installation completed and relief valves properly adjusted, slowly open the upstream and downstream shut-off valves.

Adjustment

To change the outlet pressure, remove the closing cap or loosen the locknut and turn the adjusting screw clockwise to increase outlet pressure or counterclockwise to decrease pressure. Monitor the outlet pressure with a test gauge during the adjustment. Replace the closing cap or tighten the locknut to maintain the desired setting.

Taking Out of Service (Shutdown)



WARNING

To avoid personal injury resulting from sudden release of pressure, isolate the regulator from all pressure before attempting disassembly.

Parts List

Key	Description
1	Body
2	Drain Valve (Not available for Types 67D, 67DR, 67DS and 67DSR)
3	Flange Screw
4*	O-ring (Dripwell) (Not available for Types 67D, 67DR, 67DS and 67DSR)
5	Dripwell (Not available for Types 67D, 67DR, 67DS and 67DSR)
6*	Filter Element (Not available for Types 67D, 67DR, 67DS and 67DSR)
7	Spring Case
9	Filter Retainer (Not available for Types 67D, 67DR, 67DS and 67DSR)
11*	Valve Stem
12*	Valve Spring
14*	O-ring (Spring Retainer) (Not available for Types 67DF, 67DFR, 67DFS and 67DFSR)
15*	Soft Seat
16*	Diaphragm Assembly
17	Spring
18	Adjusting Screw
19	Hex nut
20	Upper Spring Seat
22	Pressure Gauge (not shown)
23	Pipe Plug (not shown)
30	NACE Tag (not shown)
31	Panel Mounting Nut
32	Wire Seal (not shown) (For Types 67D, 67DR, 67DF and 67DFR only)
33	Closing Cap
45	Screen Vent for Types 67DS, 67DSR, 67DFS and 67DFSR only
48	Spring Retainer
49*	O-ring (Plug)
50*	O-ring (Stem)
57	Valve Plug
58*	Seat
65	Filter Retainer Screw (For Types 67DF, 67DFR, 67DFS and 67DFSR)
66*	Filter Gasket (For Types 67DF, 67DFR, 67DFS and 67DFSR)

1. Recommended spare part.

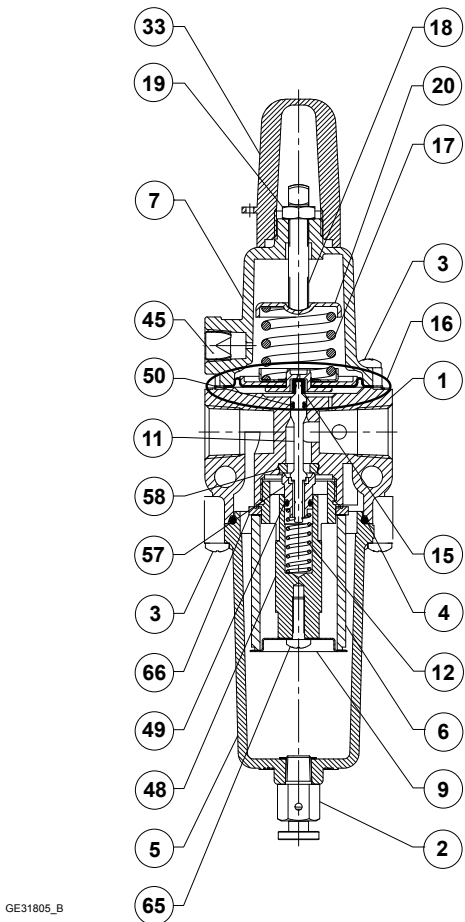

Figure 1. Types 67DFS and 67DFSR Assembly

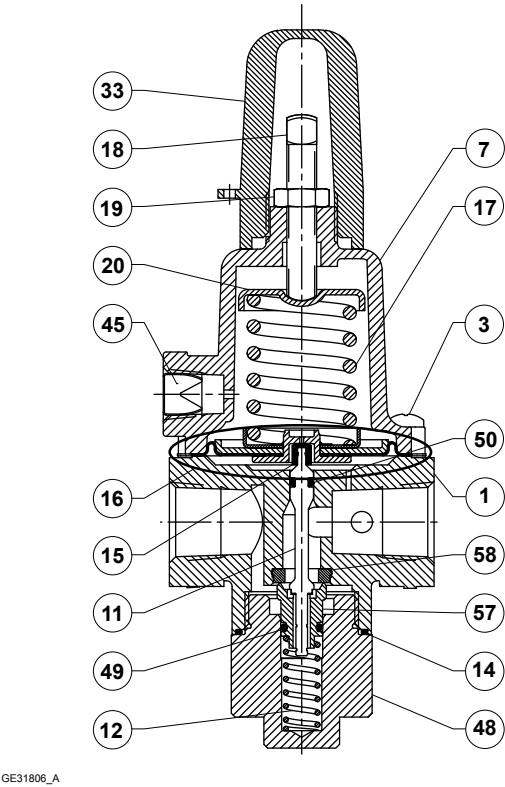

Figure 2. Types 67DS and 67DSR Assembly