

# 133 Series Direct-Operated Regulators



W1327/L

TYPES 133H, 133L, AND 133Z REGULATORS



W6803/L

TYPE 133HP REGULATOR

Figure 1. 133 Series Direct-Operated Regulators

## Features

- **Wide Pressure Range Capability with Single Regulator**—Type 133H may also use Type 133L springs, allowing pressure settings to be varied between 2 inches w.c. and 10 psig / 5 mbar and 0.69 bar by changing springs.
- **Types 133L, 133H, and 133HP Suitable for Monitoring Applications**—O-ring stem seal on Types 133L, 133H, and 133HP isolates body pressure from controlled pressure.
- **Excellent Shock Characteristics and Fast Speed of Response**—Due to two-way stabilizer vent valve, which vents the spring case more rapidly than conventional vents, lag in diaphragm and valve disk movement is minimized.
- **Bubble-Tight Shutoff**—Single-port construction, large diaphragm area, and light-rate springs along with disk material and seat design provide low lock-up pressures.
- **Spring and Diaphragm Effects Minimized**—Boosting system provides excellent performance over a wide range of flow conditions.
- **No Seat-to-Seat Adjustment Required**—Balanced single-port design eliminates necessity for seat-to-seat adjustments to achieve bubble-tight shutoff.
- **Easy Access to Trim Parts**—Valve seat, disk, and cage easily removed with body remaining in line and without disassembly of actuator portion; orifice is not threaded in.
- **Reusable Pressure Seals**—O-rings used for pressure seals, unlike gaskets, are not ordinarily damaged by disassembling the regulator.
- **Resistance to Piping Stresses**—Steel constructions are available to help resist pipe stresses.



# Bulletin 71.1:133

## Specifications

The Specifications section lists the specifications for the Type 133 Series direct-operated regulators. Factory specification is stamped on the nameplate fastened on the regulator at the factory.

### Available Constructions

**Type 133H:** Direct-operated regulator for inlet pressures to 60 psig / 4.1 bar and outlet pressures from 1.5 to 10 psig / 0.10 to 0.69 bar, three ranges.

**Type 133HP:** Direct-operated regulator for inlet pressures to 150 psig / 10.3 bar and outlet pressures from 2 to 60 psig / 0.14 to 4.1 bar, seven ranges.

**Type 133L:** Direct-operated regulator for inlet pressures to 60 psig / 4.1 bar and outlet pressures from 2 inches w.c. to 2 psig / 5 mbar to 0.14 bar, six ranges.

**Type 133Z Zero Governor:** Direct-operated regulator for inlet pressures to 20 psig / 1.4 bar and outlet pressures from -1 to 4-inches w.c. / -2.5 to 10 mbar, two ranges.

### Body Size and End Connection Styles

BODY SIZE		BODY MATERIAL	
Inch	DN	Cast Iron Body	WCC Steel Body
2	50	NPT or CL125 FF Flanged	NPT or CL150 RF Flanged

### Maximum Inlet Pressures<sup>(1)</sup>

See Table 2

### Outlet Pressure Ranges<sup>(1)</sup>

See Table 1

### Maximum Outlet Pressures<sup>(1)</sup>

See Table 2

### Pressure Registration

External; downstream control line is required

### Control Line Connection

**Types 133H, 133L, and 133Z:** 3/4 NPT internal connection will be positioned directly over body outlet (standard position) or 90° right or left of standard position if specified.

**Type 133HP:** 1/4 NPT Internal connection positioned directly over body outlet.

### Vent Connection

**Types 133H, 133L, and 133Z:** 1 NPT internal with screen; standard position is in line with control line connection directly over body outlet. Vent will always be positioned over the control line connection.

**Type 133HP:** 1/2 NPT internal connection positioned directly over body inlet with a Fisher® Type Y602-7 vent assembly.

### Temperature Capabilities<sup>(1)</sup>

-20 to 150°F / -29 to 66°C

### Flow Capacities

See Tables 3 through 10

### Wide-Open Flow Coefficients

CAPACITY	WIDE-OPEN C <sub>g</sub> FOR RELIEF VALVE SIZING	REPRESENTATIVE C <sub>1</sub>
25% <sup>(2)</sup>	490	28.2
40% <sup>(2)</sup>	760	29.1
60% <sup>(2)</sup>	1150	31.8
100%	1800	35.0

### Construction Materials

**Body:** Cast iron or WCC Steel

**Orifice and Cage:** Aluminum

**Valve Disk:** Aluminum/Neoprene (CR) or Aluminum/Fluorocarbon (FKM)<sup>(3)</sup>

**O-rings:** Nitrile (NBR) or Fluorocarbon (FKM)<sup>(3)</sup>

**Diaphragms:**

Nitrile (NBR)/Nylon (PA) (Neoprene (CR) in actuator) or Fluorocarbon (FKM)<sup>(3)</sup>/Polymer Thermoplastic

**Guide Bushing:** Nylon (PA)

**Stem and Stem Sleeve:** Stainless steel

**Diaphragm Plate:** Steel

**Balancing Diaphragm Plate:** Plated steel

**Spring Case and Closing Cap:**

*Type 133HP:* Cast Iron

*Types 133H, 133L, and 133Z:* Aluminum

**Lower Casing:**

*Types 133H, 133L, and 133Z:* Aluminum

*Type 133HP:* Steel

**Adjusting Screw:**

*Types 133H and 133Z:* Brass

*Type 133L:* Aluminum

*Type 133HP:* Steel

**Optional Restriction Collar:** Aluminum

### Approximate Shipping Weight

**Types 133H, 133L, and 133Z NPT**

**End Connections:** 35 pounds / 16 kg

**Types 133H, 133L, and 133Z Flanged**

**End Connections:** 40 pounds / 18 kg

**Type 133HP NPT End Connections:**

56.5 pounds / 26 kg

**Type 133HP Flanged End Connections:**

62.5 pounds / 28 kg

### Option

Restriction collar to reduce wide-open capacity to approximately 25%, 40%, or 60% of standard wide-open capacity.

1. The pressure/temperature limits in this Bulletin or any applicable standard limitation should not be exceeded.

2. Using optional restriction collar.

3. Available for Types 133L and 133H only.

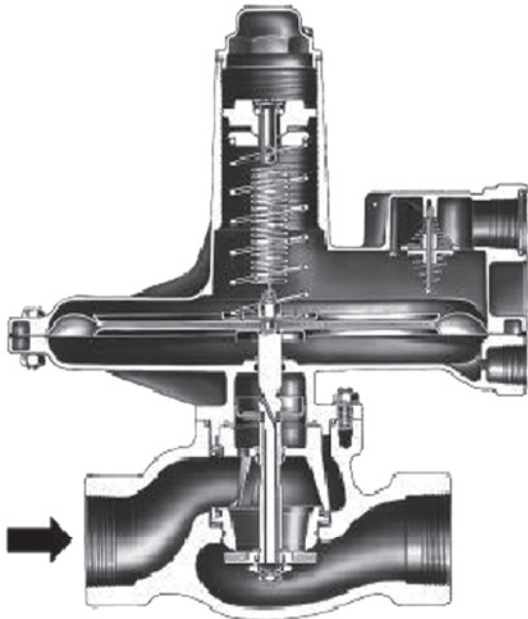

W1213-1/L

TYPE 133Z ZERO GOVERNOR

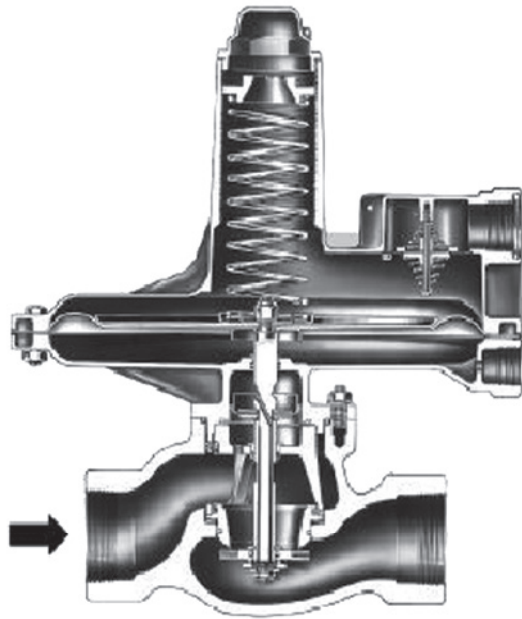

W1212-1/L

TYPE 133L LOW-PRESSURE REGULATOR

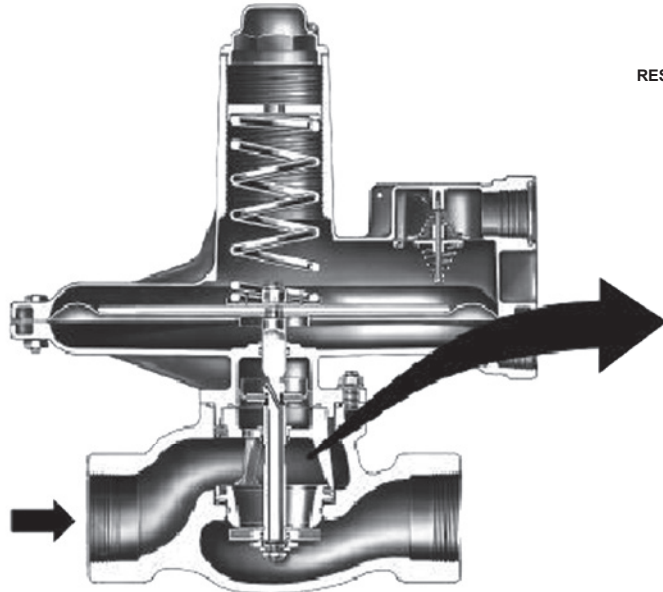

W1211-1

TYPE 133H WITHOUT RESTRICTION COLLAR

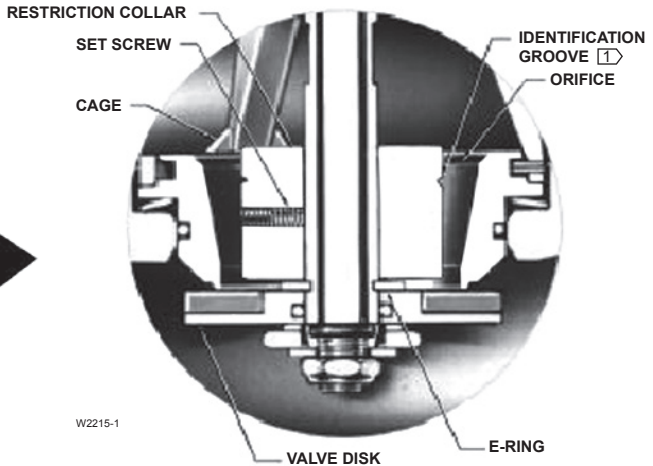

W2215-1

TRIM PARTS WITH RESTRICTION COLLAR (40% CAPACITY COLLAR IS SHOWN)

- 1 IDENTIFICATION GROOVES:
- 25% CAPACITY COLLAR—NO GROOVES
- 40% CAPACITY COLLAR—ONE GROOVE
- 60% CAPACITY COLLAR—TWO GROOVES

Figure 2. Types 133Z, 133L, and 133H Regulators

## Introduction

### Description

The 133 Series direct-operated gas regulators, shown in Figure 1 are primarily designed for industrial and commercial applications supplying gas to furnaces, burners, and other appliances. The 133 Series balancing system enables the regulator to provide accurate control of gas pressure for maximum combustion efficiency despite varying inlet pressure conditions. The single port construction provides bubble-tight shutoff. An external downstream control line is required for the operation of the regulator. Refer to Table 1 for outlet pressure ranges of each type. 133 Series regulators are available in a 2 inch / DN 50 body size with either NPT or flanged end connections.

An optional restriction collar (Figure 2) can be installed if wide-open capacity is too high for applications using a relief valve as overpressure protection. The collar reduces wide-open capacity to 25%, 40%, or 60% of standard wide-open capacity.

### Principle of Operation

Refer to the operational schematics in Figure 4. In the 133 Series, downstream pressure is registered under the diaphragm via the external control line and is used as the operating medium. Increased demand lowers the downstream pressure and allows the spring to move the diaphragm and stem assembly down, opening the valve disk and supplying more gas to the downstream system. Decreased demand increases the downstream pressure and moves the diaphragm and stem assembly up, closing the valve disk and decreasing the gas supply to the downstream system.

### Boosting System

The 133 Series incorporates a balancing diaphragm and a boosting system. When the regulator is locked up, inlet pressure is registered on the top of the valve disk and on the bottom of the balancing diaphragm through registration holes in the top of the cage. Also, downstream pressure is registered on the bottom of the valve disk and on the top of the balancing diaphragm through a passage formed by grooves in the registration disk and an annular space between the stem and stem sleeve.

When the valve disk is open, gas flows from the inlet over the edge of the valve disk to the outlet. Under the valve disk near the registration disk, there is little

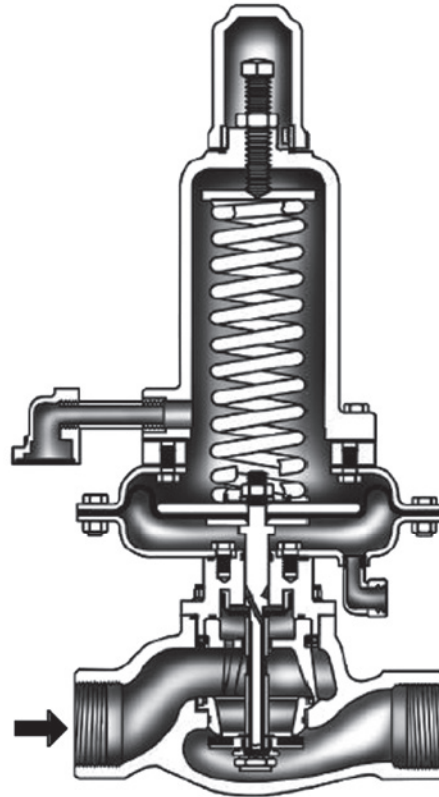

**Figure 3.** Type 133HP Regulator

gas flow. The gas pressure near the registration disk is higher than it is in the flow path where gas velocity tends to lower the pressure. The higher pressure near the disk is registered on the top of the balancing diaphragm through the registration disk and the annular space between the stem and stem sleeve.

This pressure registered on the top of the balancing diaphragm aids downward disk travel and compensates for spring and diaphragm effect. This improves regulator rangeability and performance.

### Two-Way Stabilizer Vent Valve on Types 133H, 133L, and 133Z

When the regulator responds to an increase in downstream pressure, the diaphragm moves upward. As the diaphragm rises, movement of air forces the lower vent stabilizer upward, carrying the upper stabilizer with it (see Figure 5). This allows the air above the diaphragm to vent to atmosphere rapidly enough to minimize lag in diaphragm movement.

As the diaphragm falls, air rushes in the vent to fill the partial vacuum created, forcing the upper vent

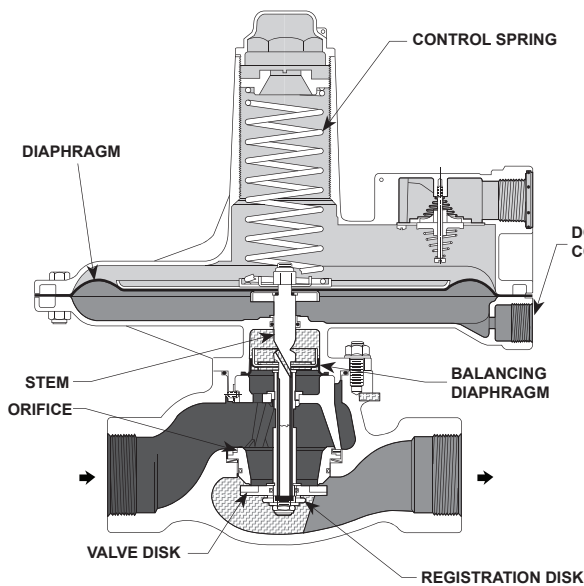

- A6555
- INLET PRESSURE
  - OUTLET PRESSURE
  - ATMOSPHERIC PRESSURE
  - BOOST PRESSURE

TYPE 133L REGULATOR

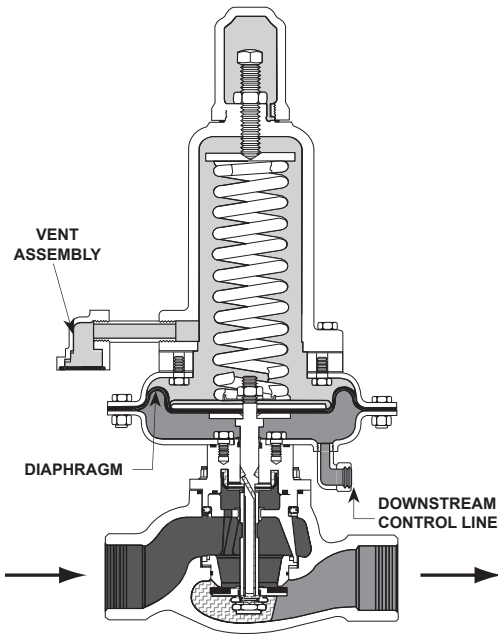

- A6883
- INLET PRESSURE
  - OUTLET PRESSURE
  - ATMOSPHERIC PRESSURE
  - BOOST PRESSURE

TYPE 133HP REGULATOR

Figure 4. Operational Schematics

stabilizer against the orifice plate. Air flowing through the webs of the upper stabilizer opens the lower stabilizer (see Figure 5). With the regulator at steady-state conditions, both stabilizers are closed and only a small hole is open to help stabilize normal operation.

**Installation**

The regulator may be installed in any position but is normally installed with the actuator portion vertical above the body portion. Flow through the body must be in the direction indicated by the flow direction arrow cast on the body portion. A downstream control line is required for operation of the regulator.

A remote vent line may be required for some installations. Vent openings must be protected against the entrance of rain, snow, insects, or any other foreign material that may plug the vent.

External dimensions are shown in Figure 9.

**Overpressure Protection**

As is the case with most regulators, the 133 Series regulators have outlet pressure ratings that are lower than the inlet pressure ratings. Some type of Overpressure Protection is needed if the actual inlet pressure ever exceeds the outlet pressure rating.

Maximum inlet and outlet pressures for the 133 Series are given in Table 2. All models must be protected against inlet pressure above the maximum emergency inlet pressure (refer to Table 2).

Outlet pressure more than 3 psig / 0.21 bar for Types 133H, 133L, and 133Z, or 40 psig / 2.8 bar for Type 133HP over the outlet pressure setting of the regulator may damage internal parts such as the diaphragm plate and valve disk.

Regulator operation below these emergency pressure limitations does not preclude the possibility of damage

# Bulletin 71.1:133

**Table 1. 133 Series Outlet Pressure Ranges, Control Springs**

TYPE	OUTLET PRESSURE RANGE		CONTROL SPRINGS					
	psig	bar	Part Number	Color Code	Free Length		Wire Diameter	
					Inch	mm	Inch	mm
133H <sup>(1)</sup>	1.5 to 3	0.10 to 0.21	1H975927032	Orange	6.91	176	0.250	6.35
	2 to 5	0.14 to 0.34	10A9440X012	Yellow	6.47	164	0.283	7.19
	5 to 10	0.34 to 0.69	1J146927142	Blue	6.19	157	0.375	9.53
133HP <sup>(1)</sup>	2 to 5	0.14 to 0.34	17B8632X012	Yellow	8.5	216	0.282	7.16
	4.5 to 10	0.31 to 0.69	17B8633X012	Orange	8.5	216	0.343	8.71
	6 to 20	0.41 to 1.4	10C1238X012	Silver	8.25	210	0.375	9.52
	16 to 30	1.1 to 2.1	10C1240X012	Red	8.25	210	0.438	11.1
	26 to 40	1.8 to 2.8	10C1241X012	Blue	8.25	210	0.500	12.7
	36 to 50	2.5 to 3.4	10C1242X012	Green	8.25	210	0.500	12.7
	45 to 60	3.1 to 4.1	10C1243X012	White	8.25	210	0.531	13.5
133L <sup>(1)</sup> and 133H <sup>(2)</sup>	2 to 4 inches w.c.	5 to 10 mbar	1D892527022	Brown	6.13	156	0.109	2.77
	3.5 to 6 inches w.c.	9 to 15 mbar	1D892627022	Red	7.53	191	0.112	2.84
	5 to 9 inches w.c.	12 to 22 mbar	1D892727012	Black	7.88	200	0.130	3.30
	8.5 to 18 inches w.c.	21 to 45 mbar	1D893227032	White	7.5	191	0.156	3.96
	14 to 28 inches w.c.	35 to 70 mbar	1D893327032	Green	7.25	184	0.182	4.62
	0.75 to 2	0.05 to 0.14	1H975827032	Blue	7.09	180	0.225	5.72
133Z <sup>(1)</sup>	-1 to 1 inch w.c.	-3 to 3 mbar	1K633427012 (Extension Spring)	Unpainted	2	50.8	0.075	1.91
	0 to 4 inches w.c.	0 to 10 mbar	1K633427012 (Extension Spring) and 1D892527022 (Compression Spring)	Unpainted  Brown	2  6.13	50.8  156	0.075  0.109	1.91  2.77

1. Pressure ranges shown are correct if the regulator is installed with the actuator portion above the body portion. If the regulator is installed with the actuator portion below the body, the pressure ranges will be lowered by approximately 2 inches w.c. / 5 mbar for the Type 133L and by approximately 3 inches w.c. / 7 mbar for the Types 133H and 133Z.  
2. If the 2 inches w.c. / 5 mbar to 2 psig / 0.14 bar springs (all 6 ranges) are used in the Type 133H, the pressure ranges will increase by approximately 1 inch w.c. / 2 mbar due to the weight of the Type 133H parts (assuming that the actuator is installed above the body).

**Table 2. Maximum Inlet and Outlet Pressures**

PRESSURES	TYPE NUMBER							
	133H		133HP		133L		133Z	
	psig	bar	psig	bar	psig	bar	psig	bar
Maximum Operating Inlet Pressure	60	4.1	150	10.3	60	4.1	20	1.4
Maximum Emergency Inlet Pressure	125	8.6			125	8.6	125	8.6
Maximum Operating Outlet Pressure <sup>(1)</sup>	10	0.69	Setpoint plus 40	Setpoint plus 2.8	2	0.14	4 inches w.c.	10 mbar
Maximum Outlet Pressure Over Outlet Pressure Setting	3	0.21			3	0.21	3	0.21
Maximum Emergency Outlet (Casing) Pressure	15	1.0	150	10.3	15	1.0	15	1.0

1. With highest spring range available only.

from external sources or from debris in the gas line. The regulator should be inspected for damage after any overpressure condition. Complete instructions for installation, operation, and maintenance are provided with each regulator.

## Capacity Data

Flow capacities for various inlet pressures and outlet pressure settings are shown in Tables 3 to 10. Capacities are in thousands of SCFH at 60°F and 14.7 psia and in thousands of Nm<sup>3</sup>/h at 0°C and 1.01325 bar of 0.6 specific gravity gas. To convert

to equivalent capacities of other gases, multiply the SCFH values shown by the appropriate factor: air–0.775; propane–0.628; butane–0.548; nitrogen–0.789. For gases of other specific gravities, multiply the given capacity by 0.775, and divide by the square root of the appropriate specific gravity. Then, if capacity is desired in Nm<sup>3</sup>/h at 0°C and 1.01325 bar, multiply SCFH by 0.0268.

### Note

**For optimum performance, select the lowest spring range that includes the desired outlet pressure setting.**

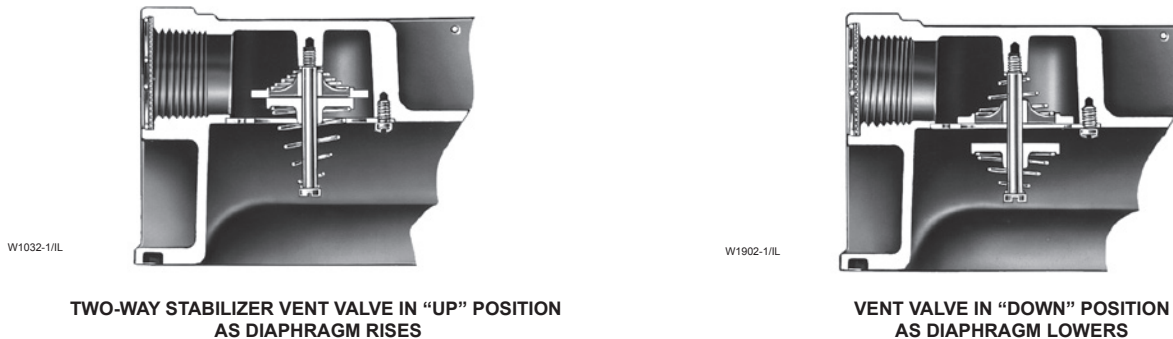

**TWO-WAY STABILIZER VENT VALVE IN "UP" POSITION AS DIAPHRAGM RISES**

**VENT VALVE IN "DOWN" POSITION AS DIAPHRAGM LOWERS**

**Figure 5. Types 133H, 133L, and 133Z Stabilizer Vent**

For restricted-capacity constructions, determine flow capacities for outlet pressure settings of 2 psig / 0.14 bar or less by multiplying the values from Tables 3 to 10 by 25%, 40%, or 60% (depending upon which restriction collar is selected). For pressure settings over 2 psig / 0.14 bar, capacities are given in Table 6. If flow capacities for inlet pressures lower than those shown are required, contact your local Sales Office. The representative regulating  $C_g$  of 1650 may be used for regulator sizing of full capacity constructions only if capacity table data is not available. The representative regulating  $C_g$  is an approximation only for pressure drops greater than 5 psi / 0.34 bar, because, at a given offset in controlled pressure, the regulating  $C_g$  varies with the spring being used with the pressure drop across the valve. To determine capacity using the flow coefficient  $C_g$ , use the appropriate procedure below.

## Critical Pressure Drops

For critical pressure drops (absolute outlet pressure equal to or less than one-half of absolute inlet pressure), use the following formula:

$$Q = (P_1)(C_g)(1.29)$$

## Non-Critical Pressure Drops

For pressure drops lower than critical (absolute outlet pressure greater than one-half of absolute inlet pressure).

$$Q = \sqrt{\frac{520}{GT}} C_g P_1 \text{SIN} \left( \frac{3417}{C_1} \sqrt{\frac{\Delta P}{P_1}} \right) \text{DEG}$$

where,

- Q = gas flow rate, SCFH
- $P_1$  = absolute inlet pressure, psia ( $P_1$  gauge + 14.7)
- $C_g$  = regulating or wide-open gas sizing coefficient
- G = specific gravity of the gas
- T = absolute temperature of gas at inlet, °Rankine
- $C_1$  = flow coefficient
- $\Delta P$  = pressure drop across the regulator, psi

**Table 3. Full-Capacity Type 133Z Regulated Flow in Thousands of SCFH of 0.6 Specific Gravity Gas at 14.7 psia and 60°F**

INLET PRESSURE		1 inch w.c. / 3 mbar OUTLET PRESSURE SETTING <sup>(1)</sup> (EITHER SPRING RANGE)			
		0.5 inch w.c. / 1 mbar Droop		1 inch w.c. / 3 mbar Droop	
psig	bar	SCFH	Nm <sup>3</sup> /h	SCFH	Nm <sup>3</sup> /h
8 inches w.c.	20 mbar	2.4	0.06	5.1	0.14
14 inches w.c.	35 mbar	4.1	0.11	7.4	0.20
1	0.07	6.5	0.17	12	0.32
2	0.14	11.5	0.31	18	0.48
5	0.34	22	0.59	32	0.86
10	0.69	44	1.18	50	1.34
20	1.4	76	2.04	78	2.09

1. Outlet pressure setting was made at approximately 10% of the maximum capacity for the listed conditions.

# Bulletin 71.1:133

**Table 4. Full-Capacity Type 133L Regulated Flow in Thousands of SCFH of 0.6 Specific Gravity Gas at 14.7 psia and 60°F**

INLET PRESSURE		OUTLET PRESSURE SETTING <sup>(1)</sup> , SPRING PART NUMBER, AND OUTLET PRESSURE RANGE																					
		4 inches w.c. / 10 mbar 1D892527022 2 to 4 inches w.c. / 5 to 10 mbar		6 inches w.c. / 15 mbar 1D892627022 3.5 to 6 inches w.c. / 8.7 to 15 mbar		7 inches w.c. / 17 mbar 1D892727012 5 to 9 inches w.c. / 12 to 22 mbar		14 inches w.c. / 35 mbar 1D893227032 8.5 to 18 inches w.c. / 21 to 45 mbar				14 inches w.c. / 35 mbar 1D893327032 14 to 28 inches w.c. / 35 to 70 mbar				1 psig / 0.07 bar 1D893327032 14 to 28 inches w.c. / 35 to 70 mbar				2 psig / 0.14 bar 1H975827032 0.75 to 2 psig / 0.05 to 0.14 bar			
psig	bar	1 inch w.c. / 3 mbar Droop		1 inch w.c. / 3 mbar Droop		1 inch w.c. / 3 mbar Droop		1 inch w.c. / 3 mbar Droop		2 inch w.c. / 5 mbar Droop		1 inch w.c. / 3 mbar Droop		2 inch w.c. / 5 mbar Droop		10% Droop		20% Droop		10% Droop		20% Droop	
		SCFH	Nm <sup>3</sup> /h	SCFH	Nm <sup>3</sup> /h	SCFH	Nm <sup>3</sup> /h	SCFH	Nm <sup>3</sup> /h	SCFH	Nm <sup>3</sup> /h	SCFH	Nm <sup>3</sup> /h	SCFH	Nm <sup>3</sup> /h	SCFH	Nm <sup>3</sup> /h	SCFH	Nm <sup>3</sup> /h	SCFH	Nm <sup>3</sup> /h	SCFH	Nm <sup>3</sup> /h
1	0.07	14	0.38	13	0.35	12	0.32	5	0.13	8.4	0.22	----	----	----	----	----	----	----	----	----	----	----	----
2	0.14	20.8	0.56	20	0.54	17	0.46	8.2	0.22	15.2	0.41	----	----	----	----	11.5	0.31	16	0.43	----	----	----	----
3	0.21	26	0.70	24.5	0.66	21	0.56	12	0.32	19.5	0.52	----	----	----	----	15.5	0.42	21.5	0.58	12.5	0.34	18.5	0.50
5	0.34	35	0.94	33	0.88	32	0.86	16	0.43	28	0.75	14	0.38	23	0.62	24	0.64	31.5	0.84	20.5	0.55	28	0.75
10	0.69	52	1.39	52	1.39	48	1.29	34	0.91	45	1.21	26	0.70	38	1.02	37.5	1.00	44	1.18	38	1.02	46	1.23
20	1.4	78	2.09	77	2.06	79	2.12	69	1.85	76	2.04	60	1.61	69	1.85	70	1.88	77	2.06	62	1.66	76	2.04
30	2.1	101	2.71	100	2.68	100	2.68	91	2.44	97	2.60	87	2.33	93	2.49	90	2.41	101	2.71	87	2.33	101	2.71
40	2.8	124	3.32	122	3.27	124	3.32	109	2.92	116	3.11	107	2.87	115	3.08	110	2.95	122	3.27	105	2.81	121	3.24
50	3.4	146	3.91	144	3.86	145	3.89	130	3.48	136	3.64	132	3.54	137	3.67	127	3.40	145	3.89	124	3.32	145	3.89
60	4.1	170	4.56	168	4.50	166	4.45	155	4.15	161	4.32	152	4.07	158	4.23	149	3.99	167	4.48	145	3.89	170	4.56

1. Outlet pressure setting was made at approximately 10% of the maximum capacity for the listed conditions.

**Table 5. Full-Capacity Type 133H Regulated Flow in Thousands of SCFH of 0.6 Specific Gravity Gas at 14.7 psia and 60°F**

INLET PRESSURE		OUTLET PRESSURE SETTING <sup>(1)</sup> , SPRING PART NUMBER, AND OUTLET PRESSURE RANGE																			
		3 psig / 0.21 bar 1H975927032 1.5 to 3 psig / 0.10 to 0.21 bar				2 psig / 0.14 bar 10A9440X012 2 to 5 psig / 0.14 to 0.34 bar				5 psig / 0.34 bar 10A9440X012 2 to 5 psig / 0.14 to 0.34 bar				5 psig / 0.34 bar 1J146927142 5 to 10 psig / 0.34 to 0.69 bar				10 psig / 0.69 bar 1J146927142 5 to 10 psig / 0.34 to 0.69 bar			
psig	bar	10% Droop		20% Droop		10% Droop		20% Droop		10% Droop		20% Droop		10% Droop		20% Droop		10% Droop		20% Droop	
		SCFH	Nm <sup>3</sup> /h	SCFH	Nm <sup>3</sup> /h	SCFH	Nm <sup>3</sup> /h	SCFH	Nm <sup>3</sup> /h	SCFH	Nm <sup>3</sup> /h	SCFH	Nm <sup>3</sup> /h	SCFH	Nm <sup>3</sup> /h	SCFH	Nm <sup>3</sup> /h	SCFH	Nm <sup>3</sup> /h	SCFH	Nm <sup>3</sup> /h
3	0.21	----	----	----	----	6.5	0.17	11.5	0.31	----	----	----	----	----	----	----	----	----	----	----	----
5	0.34	14	0.38	22	0.59	11	0.30	18	0.48	----	----	----	----	----	----	----	----	----	----	----	----
7	0.48	21.5	0.58	31	0.83	13	0.35	22	0.59	15.5	0.42	24	0.64	9	0.24	15	0.40	----	----	----	----
10	0.69	28	0.75	42	1.13	15	0.40	27	0.72	24	0.64	35	0.94	14	0.38	22	0.59	----	----	----	----
15	1.0	40	1.07	57	1.53	25.5	0.68	39	1.04	35	0.94	51	1.37	19	0.51	31.5	0.84	21	0.56	35	0.94
20	1.4	52	1.39	72	1.93	35	0.94	52	1.39	46	1.23	67	1.80	24	0.64	41	1.10	31	0.83	51	1.37
30	2.1	76	2.04	96	2.57	49	1.31	73	1.96	68	1.82	95	2.55	35	0.94	58	1.55	44	1.18	74	1.98
40	2.8	98	2.63	119	3.19	66	1.77	97	2.60	88	2.36	117	3.14	44	1.18	73	1.96	56	1.50	97	2.60
50	3.4	118	3.16	141	3.78	84	2.25	112	3.00	103	2.76	138	3.70	57	1.53	89	2.38	74	1.98	117	3.14
60	4.1	136	3.64	165	4.42	104	2.79	132	3.54	122	3.27	156	4.18	65	1.74	106	2.84	91	2.44	136	3.64

1. Outlet pressure setting was made at approximately 10% of the maximum capacity for the listed conditions.



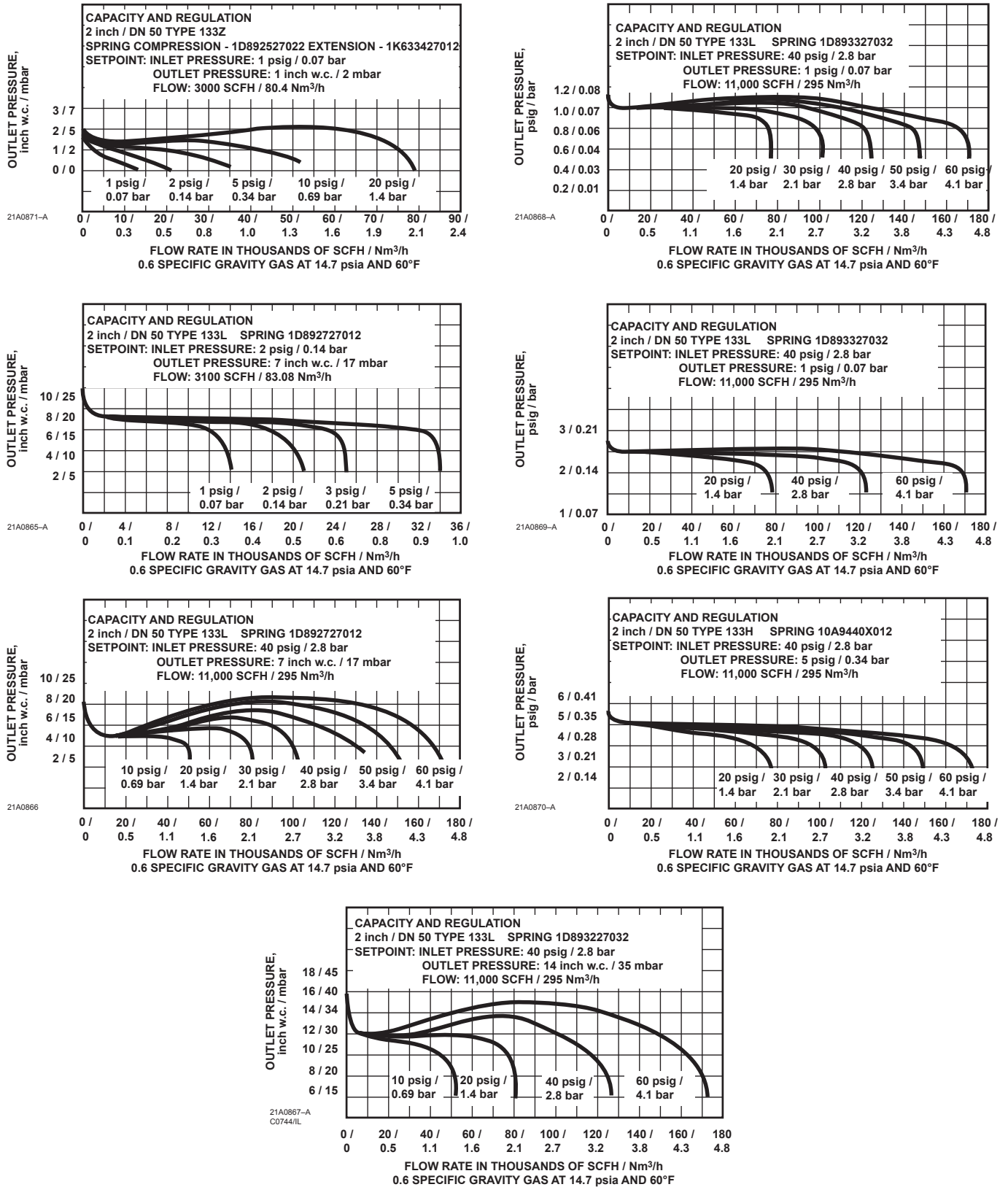

Figure 6. Capacity Curves — Full-Capacity Constructions

# Bulletin 71.1:133

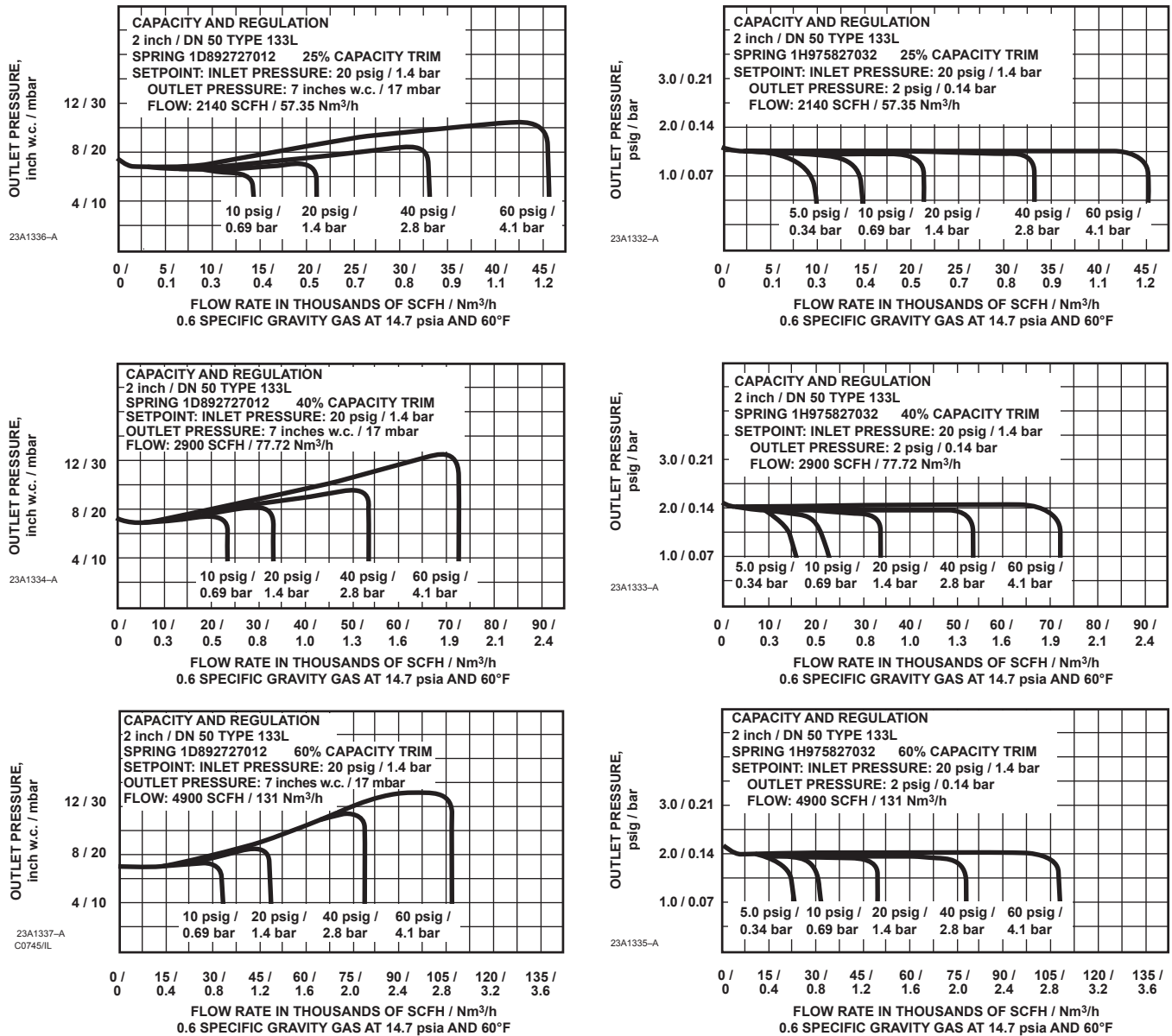

Figure 7. Capacity Curves — Restricted Capacity Constructions

**Table 6. Restricted-Capacity Type 133H Regulated Flow in Thousands of SCFH of 0.6 Specific Gravity Gas at 14.7 psia and 60°F**

INLET PRESSURE		OUTLET PRESSURE SETTING <sup>(1)</sup> , SPRING PART NUMBER, AND OUTLET PRESSURE RANGE																							
		25% Capacity								40% Capacity								60% Capacity							
		5 psig / 0.34 bar 10A9440X012 2 to 5 psig / 0.14 to 0.34 bar				10 psig / 0.69 bar 1J146927142 5 to 10 psig / 0.34 to 0.69 bar				5 psig / 0.34 bar 10A9440X012 2 to 5 psig / 0.14 to 0.34 bar				10 psig / 0.69 bar 1J146927142 5 to 10 psig / 0.34 to 0.69 bar				5 psig / 0.34 bar 10A9440X012 2 to 5 psig / 0.14 to 0.34 bar				10 psig / 0.69 bar 1J146927142 5 to 10 psig / 0.34 to 0.69 bar			
psig	bar	10% Droop		20% Droop		10% Droop		20% Droop		10% Droop		20% Droop		10% Droop		20% Droop		10% Droop		20% Droop		10% Droop		20% Droop	
		SCFH	Nm <sup>3</sup> /h	SCFH	Nm <sup>3</sup> /h	SCFH	Nm <sup>3</sup> /h	SCFH	Nm <sup>3</sup> /h	SCFH	Nm <sup>3</sup> /h	SCFH	Nm <sup>3</sup> /h	SCFH	Nm <sup>3</sup> /h	SCFH	Nm <sup>3</sup> /h	SCFH	Nm <sup>3</sup> /h	SCFH	Nm <sup>3</sup> /h	SCFH	Nm <sup>3</sup> /h	SCFH	Nm <sup>3</sup> /h
7	0.48	8.0	0.21	9.0	0.24	----	----	----	----	11.0	0.30	15.0	0.40	----	----	----	----	13.0	0.35	17.0	0.46	----	----	----	----
10	0.69	12.3	0.33	13.0	0.35	----	----	----	----	16.5	0.44	20.0	0.54	----	----	----	----	20.0	0.54	25.0	0.67	----	----	----	----
15	1.0	----	----	----	----	13.0	0.35	15.5	0.42	----	----	----	----	16.5	0.44	23.5	0.63	----	----	----	----	20.0	0.54	29.5	0.79
20	1.4	20.8	0.56	21.2	0.57	17.5	0.47	20.0	0.54	31.5	0.84	33.5	0.90	23.5	0.63	30.5	0.82	36.0	0.96	46.5	1.25	29.0	0.78	39.5	1.06
40	2.8	33.5	0.90	33.5	0.90	33.0	0.88	33.5	0.90	52.0	1.39	53.2	1.43	46.0	1.23	53.2	1.43	70.0	1.88	77.5	2.08	57.0	1.53	74.5	2.00
60	4.1	45.5	1.22	45.5	1.22	45.5	1.22	45.5	1.22	72.7	1.95	72.7	1.95	67.0	1.80	72.7	1.95	105	2.81	107	2.87	87.0	2.33	107	2.87

1. Outlet pressure setting was made at approximately 10% of the maximum capacity for the listed conditions.

**Table 7. Type 133HP Regulator 100% Capacities in Thousands of SCFH of 0.6 Specific Gravity Gas at 14.7 psia and 60°F**

OUTLET PRESSURE RANGE, CONTROL SPRING NUMBER, AND COLOR	OUTLET PRESSURE SETTING <sup>(1)</sup>		INLET PRESSURE		2-INCH / DN 50 BODY SIZE 1.91-INCH / 48.5 mm ORIFICE SIZE					
					Droop from Setpoint					
					10%		20%		30%	
	psig	bar	psig	bar	SCFH	Nm <sup>3</sup> /h	SCFH	Nm <sup>3</sup> /h	SCFH	Nm <sup>3</sup> /h
2 to 5 psig / 0.14 to 0.34 bar  17B8632X012  Yellow	2	0.14	10	0.69	10.4	0.28	18.9	0.51	27.5	0.74
			20	1.4	16.4	0.44	29.8	0.80	43.3	1.16
			40	2.8	27.0	0.72	49.1	1.32	71.2	1.91
			60	4.1	37.1	0.99	67.5	1.81	97.9	2.62
			80	5.5	47.2	1.26	85.7	2.30	124.3	3.33
			100	6.9	57.1	1.53	103.9	2.78	150.6	4.04
			125	8.6	69.5	1.86	126.5	3.39	183.4	4.92
			150	10.3	82.0	2.20	149.1	4.00	216.3	5.80
			10	0.69	20.2	0.54	41.5	1.11	42.8	1.15
			20	1.4	35.1	0.94	71.7	1.92	72.3	1.94
40	2.8	59.6	1.60	121.3	3.25	121.5	3.26			
60	4.1	82.4	2.21	167.9	4.50	168.0	4.50			
80	5.5	104.9	2.81	213.6	5.72	213.6	5.72			
100	6.9	127.2	3.41	258.9	6.94	258.9	6.94			
125	8.6	155.0	4.15	315.4	8.45	315.4	8.45			
150	10.3	182.7	4.90	371.8	9.96	371.8	9.96			

1. Outlet pressure setting was made at approximately 10% of the maximum capacity for the listed conditions.

Gray areas indicate maximum flow capacity.

- continued -

# Bulletin 71.1:133

**Table 7. Type 133HP Regulator 100% Capacities in Thousands of SCFH of 0.6 Specific Gravity Gas at 14.7 psia and 60°F**

OUTLET PRESSURE RANGE, CONTROL SPRING NUMBER, AND COLOR	OUTLET PRESSURE SETTING <sup>(1)</sup>		INLET PRESSURE		2-INCH / DN 50 BODY SIZE 1.91-INCH / 48.5 mm ORIFICE SIZE						
					Droop from Setpoint						
	psig	bar	psig	bar	10%		20%		30%		
					SCFH	Nm <sup>3</sup> /h	SCFH	Nm <sup>3</sup> /h	SCFH	Nm <sup>3</sup> /h	
4.5 to 10 psig / 0.31 to 0.69 bar  17B8633X012  Orange	5	0.34	10	0.69	11.4	0.31	21.4	0.57	32.0	0.86	
			20	1.4	19.6	0.52	36.4	0.98	53.4	1.43	
			40	2.8	33.0	0.88	61.3	1.64	89.6	2.40	
			60	4.1	45.7	1.22	84.7	2.27	123.7	3.32	
			80	5.5	58.1	1.56	107.7	2.89	157.3	4.22	
			100	6.9	70.5	1.89	130.6	3.50	190.7	5.11	
			125	8.6	85.8	2.30	159.0	4.26	232.2	6.22	
			150	10.3	101.2	2.71	187.5	5.02	273.8	7.34	
	10	0.69	25	1.7	40.3	1.08	80.5	2.16	81.7	2.19	
			30	2.1	47.1	1.26	93.9	2.52	94.8	2.54	
			40	2.8	59.9	1.60	119.1	3.19	119.7	3.21	
			60	4.1	84.0	2.25	166.8	4.47	167.1	4.48	
			80	5.5	107.4	2.88	213.0	5.71	213.2	5.71	
			100	6.9	130.4	3.50	258.7	6.93	258.8	6.94	
			125	8.6	159.0	4.26	315.4	8.45	315.4	8.45	
			150	10.3	187.5	5.02	371.8	9.96	371.8	9.96	
	6 to 20 psig / 0.41 to 1.4 bar  10C1238X012  Silver	10	0.69	15	1.0	16.4	0.44	32.0	0.86	51.9	1.39
				20	1.4	22.1	0.59	42.2	1.13	67.7	1.81
40				2.8	39.9	1.07	75.4	2.02	111.0	2.98	
60				4.1	55.9	1.50	105.0	2.81	155.0	4.15	
80				5.5	71.4	1.91	134.0	3.59	198.0	5.31	
100				6.9	86.8	2.33	163.0	4.37	240.0	6.43	
125				8.6	106.0	2.84	199.0	5.33	292.0	7.83	
150				10.3	125.0	3.35	235.0	6.30	344.0	9.22	
20		1.4	25	1.7	38.8	1.39	65.0	1.74	70.0	1.88	
			30	2.1	50.3	1.81	82.3	2.21	86.0	2.30	
			40	2.8	69.4	2.98	112.0	3.00	114.0	3.06	
			60	4.1	102.0	4.15	163.0	4.37	164.0	4.40	
			80	5.5	133.0	5.31	211.0	5.66	211.0	5.66	
			100	6.9	162.0	6.43	257.0	6.89	258.0	6.91	
			125	8.6	198.0	7.83	315.0	8.44	315.0	8.44	
			150	10.3	234.0	9.22	372.0	9.97	372.0	9.97	
16 to 30 psig / 1.1 to 2.1 bar  10C1240X012  Red		20	1.4	25	1.7	24.8	0.66	50.4	1.35	70.0	1.88
				30	2.1	31.8	0.85	62.6	1.68	86.0	2.30
	40			2.8	43.5	1.17	84.0	2.25	114.0	3.06	
	60			4.1	63.8	1.71	122.0	3.27	164.0	4.40	
	80			5.5	83.0	2.22	158.0	4.23	211.0	5.66	
	100			6.9	101.0	2.71	192.0	5.15	258.0	6.91	
	125			8.6	124.0	3.23	235.0	6.30	315.0	8.44	
	150			10.3	146.0	3.91	277.0	7.42	372.0	9.97	
	30	2.1	35	2.4	43.0	1.15	80.6	2.16	88.2	2.36	
			40	2.8	53.8	1.44	98.4	2.64	104.0	2.79	
			60	4.1	88.0	2.36	156.0	4.18	159.0	4.26	
			80	5.5	117.0	3.14	207.0	5.55	208.0	5.57	
			100	6.9	145.0	3.89	255.0	6.83	256.0	6.86	
			125	8.6	178.0	4.77	313.0	8.39	314.0	8.42	
			150	10.3	211.0	5.66	371.0	9.94	371.0	9.94	

1. Outlet pressure setting was made at approximately 10% of the maximum capacity for the listed conditions.  
 Gray areas indicate maximum flow capacity.

- continued -

**Table 7. Type 133HP Regulator 100% Capacities in Thousands of SCFH of 0.6 Specific Gravity Gas at 14.7 psia and 60°F (continued)**

OUTLET PRESSURE RANGE, CONTROL SPRING NUMBER, AND COLOR	OUTLET PRESSURE SETTING <sup>(1)</sup>		INLET PRESSURE		2-INCH / DN 50 BODY SIZE 1.91-INCH / 48.5 mm ORIFICE SIZE					
					Droop from Setpoint					
					10%		20%		30%	
	psig	bar	psig	bar	SCFH	Nm <sup>3</sup> /h	SCFH	Nm <sup>3</sup> /h	SCFH	Nm <sup>3</sup> /h
26 to 40 psig / 1.8 to 2.8 bar  10C1241X012  Blue	30	2.1	35	2.4	28.9	0.78	59.6	1.60	88.2	2.36
			40	2.8	35.7	0.96	71.0	1.90	104.0	2.79
			60	4.1	57.5	1.54	110.0	2.95	159.0	4.26
			80	5.5	76.4	2.05	146.0	3.91	208.0	5.57
			100	6.9	94.3	2.53	179.0	4.80	256.0	6.86
			125	8.6	116.0	3.11	220.0	5.90	314.0	8.42
			150	10.3	137.0	3.67	260.0	6.97	371.0	9.94
	40	2.8	45	3.1	43.5	1.17	96.2	2.58	106.0	2.84
			50	3.4	52.6	1.41	114.0	3.06	122.0	3.27
			60	4.1	68.4	1.83	146.0	3.91	151.0	4.05
			80	5.5	95.4	2.56	186.0	4.98	204.0	5.47
			100	6.9	120.0	3.22	232.0	6.22	253.0	6.78
			125	8.6	149.0	3.99	287.0	7.69	312.0	8.36
			150	10.3	177.0	4.74	341.0	9.14	370.0	9.92
36 to 50 psig / 2.5 to 3.4 bar  10C1242X012  Green	40	2.8	45	3.1	36.2	0.97	76.1	2.04	106.0	2.84
			50	3.4	43.4	1.16	88.1	2.36	122.0	3.27
			60	4.1	56.2	1.51	110.0	2.95	151.0	4.05
			80	5.5	78.1	2.09	150.0	4.02	204.0	5.47
			100	6.9	97.9	2.62	187.0	5.01	253.0	6.78
			125	8.6	122.0	3.27	232.0	6.22	312.0	8.36
			150	10.3	145.0	3.89	276.0	7.40	370.0	9.92
	50	3.4	55	3.8	50.4	1.35	112.0	3.00	124.0	3.32
			60	4.1	59.5	1.60	130.0	3.48	141.0	3.78
			80	5.5	90.2	2.42	191.0	5.12	197.0	5.28
			100	6.9	116.0	3.11	227.0	6.08	248.0	6.65
			125	8.6	147.0	3.94	283.0	7.58	309.0	8.28
			150	10.3	176.0	4.72	338.0	9.06	368.0	9.86
			45 to 60 psig / 3.1 to 4.1 bar  10C1243X012  White	50	3.4	55	3.8	43.5	1.17	92.7
60	4.1	51.0				1.37	105.0	2.81	141.0	3.78
80	5.5	76.9				2.06	151.0	4.05	197.0	5.28
100	6.9	99.0				2.65	191.0	5.12	248.0	6.65
125	8.6	125.0				3.35	239.0	6.40	309.0	8.28
150	10.3	149.0				3.99	285.0	7.64	368.0	9.86
60	4.1	65				4.5	57.5	1.54	127.0	3.40
		70		4.8	66.5	1.78	146.0	3.91	159.0	4.26
		80		5.5	83.2	2.23	179.0	4.80	188.0	5.04
		100		6.9	112.0	3.00	236.0	6.32	242.0	6.49
		125		8.6	144.0	3.86	280.0	7.50	305.0	8.17
		150		10.3	174.0	4.66	336.0	9.00	365.0	9.78

1. Outlet pressure setting was made at approximately 10% of the maximum capacity for the listed conditions.  
 Gray areas indicate maximum flow capacity.

# Bulletin 71.1:133

**Table 8. Type 133HP Regulator 25% Capacities in Thousands of SCFH of 0.6 Specific Gravity Gas at 14.7 psia and 60°F**

OUTLET PRESSURE RANGE, CONTROL SPRING NUMBER, AND COLOR	OUTLET PRESSURE SETTING <sup>(1)</sup>		INLET PRESSURE		2-INCH / DN 50 BODY SIZE 1.91-INCH / 48.5 mm ORIFICE SIZE					
					Droop from Setpoint					
					10%		20%		30%	
	psig	bar	psig	bar	SCFH	Nm <sup>3</sup> /h	SCFH	Nm <sup>3</sup> /h	SCFH	Nm <sup>3</sup> /h
2 to 5 psig / 0.14 to 0.34 bar  17B8632X012  Yellow	2	0.14	10	0.69	4.0	0.11	7.8	0.21	13.4	0.36
			20	1.4	6.4	0.17	12.5	0.34	12.2	0.33
			40	2.8	10.5	0.28	20.6	0.55	34.9	0.94
			60	4.1	14.5	0.39	28.4	0.76	48.1	1.29
			80	5.5	18.4	0.49	36.0	0.97	61.1	1.64
			100	6.9	22.3	0.60	43.7	1.17	74.0	1.98
			125	8.6	27.2	0.73	53.2	1.43	90.1	2.42
	150	10.3	32.0	0.86	62.7	1.68	106.2	2.85		
	5	0.34	10	0.69	8.3	0.22	11.5	0.31	11.9	0.32
			20	1.4	14.9	0.40	20.3	0.54	20.5	0.55
			40	2.8	25.4	0.68	34.6	0.93	34.7	0.93
			60	4.1	35.2	0.94	47.9	1.28	48.0	1.29
			80	5.5	44.8	1.20	61.0	1.64	61.0	1.64
			100	6.9	54.3	1.46	74.0	1.98	74.0	1.98
125			8.6	66.2	1.77	90.1	2.42	90.1	2.42	
150	10.3	78.1	2.09	106.2	2.85	106.2	2.85			
4.5 to 10 psig / 0.31 to 0.69 bar  17B8633X012  Orange	5	0.34	10	0.69	4.4	0.12	8.7	0.23	11.9	0.32
			20	1.4	7.8	0.21	15.4	0.41	20.5	0.55
			40	2.8	13.3	0.36	26.1	0.70	34.7	0.93
			60	4.1	18.4	0.49	36.2	0.97	48.0	1.29
			80	5.5	23.4	0.63	46.1	1.24	61.0	1.64
			100	6.9	28.4	0.76	55.9	1.50	74.0	1.98
			125	8.6	34.6	0.93	68.1	1.83	90.1	2.42
	150	10.3	40.8	1.09	80.2	2.15	106.2	2.85		
	10	0.69	25	1.7	17.0	0.46	22.6	0.61	23.0	0.62
			30	2.1	19.9	0.53	26.5	0.71	26.8	0.72
			40	2.8	25.5	0.68	33.8	0.91	34.0	0.91
			60	4.1	35.9	0.96	47.5	1.27	47.6	1.28
			80	5.5	45.9	1.23	60.8	1.63	60.9	1.63
			100	6.9	55.8	1.50	73.9	1.98	73.9	1.98
125			8.6	68.0	1.82	90.1	2.42	90.1	2.42	
150	10.3	80.2	2.15	106.2	2.85	106.2	2.85			
6 to 20 psig / 0.41 to 1.4 bar  10C1238X012  Silver	10	0.69	15	1.0	6.3	0.17	13.3	0.36	14.1	0.38
			20	1.4	8.8	0.24	18.3	0.49	18.9	0.51
			40	2.8	16.4	0.44	33.8	0.91	34.0	0.91
			60	4.1	23.1	0.62	47.5	1.27	47.6	1.28
			80	5.5	29.5	0.79	60.8	1.63	60.9	1.63
			100	6.9	35.8	0.96	73.9	1.98	73.9	1.98
			125	8.6	43.7	1.17	90.1	2.42	90.1	2.42
	150	10.3	51.5	1.38	106.2	2.85	106.2	2.85		
	20	1.4	25	1.7	15.7	0.42	16.8	0.45	18.6	0.50
			30	2.1	21.6	0.58	22.3	0.60	23.5	0.63
			40	2.8	30.7	0.82	31.1	0.83	31.9	0.86
			60	4.1	45.9	1.23	46.1	1.24	46.5	1.25
			80	5.5	59.8	1.60	60.0	1.61	60.2	1.61
			100	6.9	73.3	1.96	73.4	1.97	73.5	1.97
125			8.6	89.8	2.41	89.8	2.41	89.9	2.41	
150	10.3	106.1	2.84	106.1	2.84	106.2	2.85			

1. Outlet pressure setting was made at approximately 10% of the maximum capacity for the listed conditions.  
 Gray areas indicate maximum flow capacity.

- continued -

**Table 8. Type 133HP Regulator 25% Capacities in Thousands of SCFH of 0.6 Specific Gravity Gas at 14.7 psia and 60°F (continued)**

OUTLET PRESSURE RANGE, CONTROL SPRING NUMBER, AND COLOR	OUTLET PRESSURE SETTING <sup>(1)</sup>		INLET PRESSURE		2-INCH / DN 50 BODY SIZE 1.91-INCH / 48.5 mm ORIFICE SIZE					
					Droop from Setpoint					
	psig	bar	psig	bar	10%		20%		30%	
					SCFH	Nm <sup>3</sup> /h	SCFH	Nm <sup>3</sup> /h	SCFH	Nm <sup>3</sup> /h
16 to 30 psig / 1.1 to 2.1 bar  10C1240X012  Red	20	1.4	25	1.7	9.2	0.25	16.8	0.45	18.6	0.50
			30	2.1	12.6	0.34	22.3	0.60	23.5	0.63
			40	2.8	17.8	0.48	31.1	0.83	31.9	0.86
			60	4.1	26.6	0.71	46.1	1.24	46.5	1.25
			80	5.5	34.6	0.93	60.0	1.61	60.2	1.61
			100	6.9	42.3	1.13	73.4	1.97	73.5	1.97
			125	8.6	51.9	1.39	89.8	2.41	89.9	2.41
	150	10.3	61.3	1.64	106.1	2.84	106.2	2.85		
	30	2.1	35	2.4	18.5	0.50	20.2	0.54	23.0	0.62
			40	2.8	21.5	0.58	26.1	0.70	28.1	0.75
			60	4.1	37.1	0.99	43.6	1.17	44.6	1.20
			80	5.5	50.0	1.34	58.4	1.56	59.0	1.58
			100	6.9	62.1	1.66	72.3	1.94	72.7	1.95
			125	8.6	76.6	2.05	89.2	2.39	89.4	2.40
150			10.3	90.9	2.44	105.7	2.83	105.9	2.84	
26 to 40 psig / 1.8 to 2.8 bar  10C1241X012  Blue	30	2.1	35	2.4	10.3	0.28	20.2	0.54	23.0	0.62
			40	2.8	13.6	0.36	26.1	0.70	28.1	0.75
			60	4.1	23.4	0.63	43.6	1.17	44.6	1.20
			80	5.5	31.6	0.85	58.4	1.56	59.0	1.58
			100	6.9	39.1	1.05	72.3	1.94	72.7	1.95
			125	8.6	48.3	1.29	89.2	2.39	89.4	2.40
			150	10.3	57.3	1.54	105.7	2.83	105.9	2.84
	40	2.8	45	3.1	15.5	0.42	23.7	0.64	27.5	0.74
			50	3.4	20.3	0.54	29.7	0.80	32.7	0.88
			60	4.1	27.8	0.74	39.6	1.06	41.6	1.12
			80	5.5	39.9	1.07	56.0	1.50	57.2	1.53
			100	6.9	50.6	1.36	70.7	1.90	71.5	1.92
			125	8.6	63.2	1.69	88.1	2.36	88.6	2.37
			150	10.3	75.4	2.02	105.0	2.81	105.4	2.82
36 to 50 psig / 2.5 to 3.4 bar  10C1242X012  Green	40	2.8	45	3.1	12.5	0.34	23.7	0.64	27.5	0.74
			50	3.4	16.4	0.44	29.7	0.80	32.7	0.88
			60	4.1	22.4	0.60	39.6	1.06	41.6	1.12
			80	5.5	32.1	0.86	56.0	1.50	57.2	1.53
			100	6.9	40.7	1.09	70.7	1.90	71.5	1.92
			125	8.6	50.8	1.36	88.1	2.36	88.6	2.37
			150	10.3	60.6	1.62	105.0	2.81	105.4	2.82
	50	3.4	55	3.8	17.5	0.47	27.0	0.72	31.9	0.86
			60	4.1	22.5	0.60	33.3	0.89	37.2	1.00
			80	5.5	37.1	0.99	52.5	1.41	54.6	1.46
			100	6.9	48.7	1.30	68.4	1.83	69.8	1.87
			125	8.6	61.9	1.66	86.6	2.32	87.5	2.34
			150	10.3	74.5	2.00	103.9	2.78	104.5	2.80
			45 to 60 psig / 3.1 to 4.1 bar  10C1243X012  White	50	3.4	55	3.8	14.8	0.40	27.0
60	4.1	18.9				0.51	33.3	0.89	37.2	1.00
80	5.5	31.1				0.83	52.5	1.41	54.6	1.46
100	6.9	40.9				1.10	68.4	1.83	69.8	1.87
125	8.6	52.0				1.39	86.6	2.32	87.5	2.34
150	10.3	62.5				1.68	103.9	2.78	104.5	2.80
60	4.1	65				4.5	19.5	0.52	30.4	0.82
		70		4.8	24.7	0.66	36.9	0.99	41.7	1.12
		80		5.5	33.1	0.83	47.6	1.28	51.1	1.37
		100		6.9	46.3	1.24	65.2	1.75	67.4	1.81
		125		8.6	60.4	1.62	84.5	2.26	85.9	2.30
		150		10.3	73.5	1.97	102.4	2.74	103.4	2.77

1. Outlet pressure setting was made at approximately 10% of the maximum capacity for the listed conditions.  
 Gray areas indicate maximum flow capacity.

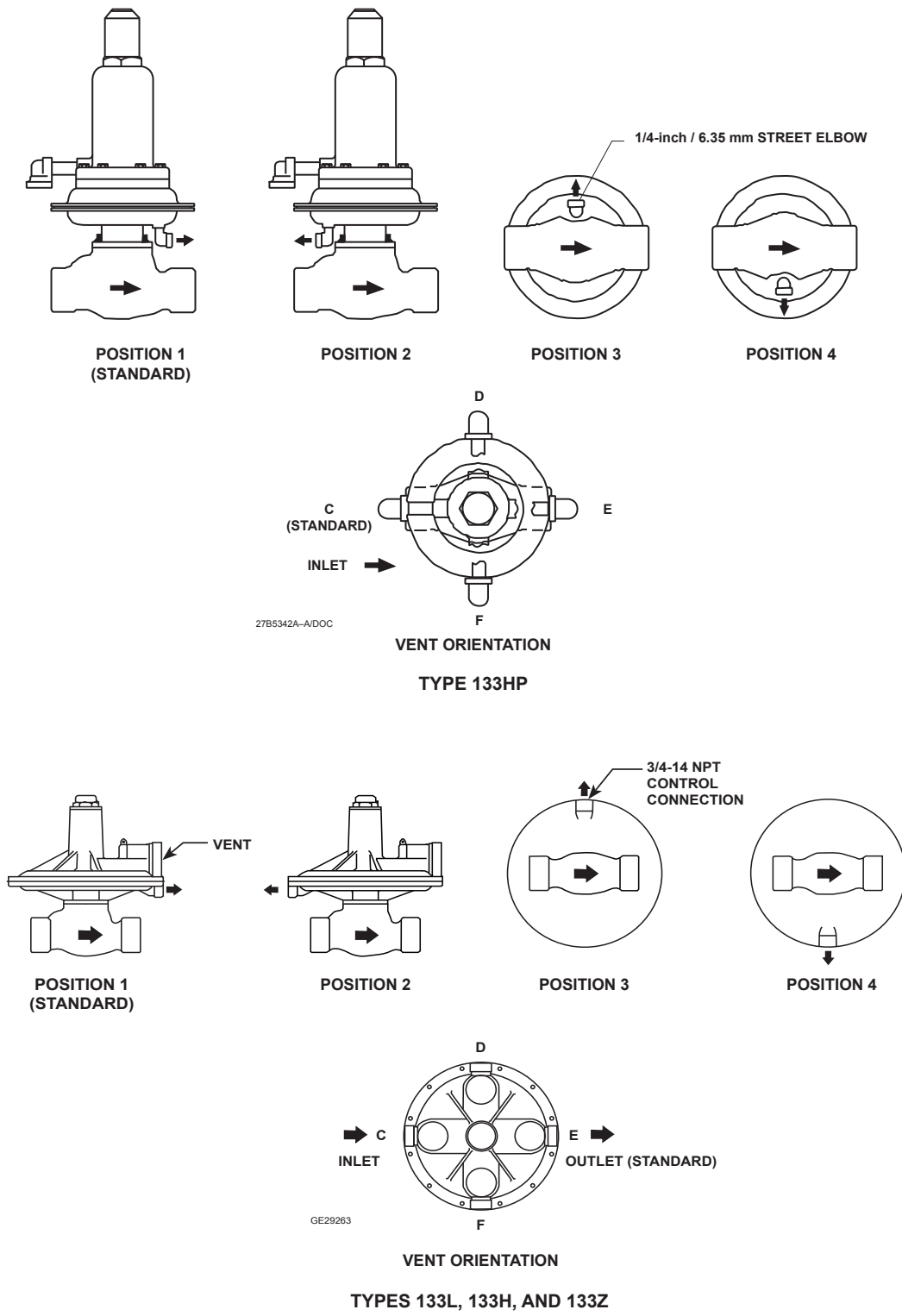



Figure 8. 133 Series Assembly Positions for Body/Spring Case Orientation



Table 9. Type 133HP Regulator 40% Capacities in Thousands of SCFH of 0.6 Specific Gravity Gas at 14.7 psia and 60°F

OUTLET PRESSURE RANGE, CONTROL SPRING NUMBER, AND COLOR	OUTLET PRESSURE SETTING <sup>(1)</sup>		INLET PRESSURE		2-INCH / DN 50 BODY SIZE 1.91-INCH / 48.5 mm ORIFICE SIZE					
					Droop from Setpoint					
					10%		20%		30%	
					psig	bar	psig	bar	SCFH	Nm <sup>3</sup> /h
2 to 5 psig / 0.14 to 0.34 bar  17B8632X012  Yellow	2	0.14	10	0.69	6.9	0.18	13.2	0.35	19.7	0.53
			20	1.4	10.5	0.28	20.1	0.54	29.7	0.80
			40	2.8	16.6	0.44	31.9	0.86	47.2	1.26
			60	4.1	22.7	0.61	43.6	1.17	64.4	1.73
			80	5.5	28.8	0.77	55.2	1.48	81.7	2.19
			100	6.9	34.8	0.93	66.9	1.79	99.0	2.65
			125	8.6	42.4	1.14	81.5	2.18	120.5	3.23
	150	10.3	50.0	1.34	96.0	2.57	142.1	3.81		
	5	0.34	10	0.69	14.5	0.39	19.8	0.53	20.4	0.55
			20	1.4	24.4	0.65	32.8	0.88	32.9	0.88
			40	2.8	39.5	1.06	52.9	1.42	52.9	1.42
			60	4.1	54.0	1.45	72.3	1.94	72.3	1.94
			80	5.5	68.5	1.84	91.6	2.46	91.6	2.46
			100	6.9	82.9	2.22	111.0	2.98	111.0	2.98
125			8.6	101.0	2.71	135.2	3.62	135.2	3.62	
150	10.3	119.1	3.19	159.3	4.27	159.3	4.27			
4.5 to 10 psig / 0.31 to 0.69 bar  17B8633X012  Orange	5	0.34	10	0.69	3.8	0.10	7.1	0.19	10.4	0.28
			20	1.4	5.8	0.16	10.7	0.29	15.7	0.42
			40	2.8	9.2	0.25	17.0	0.46	24.9	0.67
			60	4.1	12.5	0.34	23.3	0.62	34.0	0.91
			80	5.5	15.9	0.43	29.5	0.79	43.1	1.16
			100	6.9	19.3	0.52	35.7	0.96	52.2	1.40
			125	8.6	23.5	0.63	43.5	1.17	63.6	1.70
	150	10.3	27.7	0.74	51.3	1.38	75.0	2.01		
	10	0.69	25	1.7	28.2	0.76	37.0	0.99	37.4	1.00
			30	2.1	32.5	0.87	42.6	1.14	42.8	1.15
			40	2.8	40.5	1.08	52.9	1.42	52.9	1.42
			60	4.1	55.5	1.49	72.3	1.94	72.3	1.94
			80	5.5	70.4	1.89	91.6	2.46	91.6	2.46
			100	6.9	85.2	2.28	111.0	2.98	111.0	2.98
125			8.6	103.8	2.78	135.2	3.62	135.2	3.62	
150	10.3	122.4	3.28	159.3	4.27	159.3	4.27			
6 to 20 psig / 0.41 to 1.4 bar  10C1238X012  Silver	10	0.69	15	1.03	11.3	0.30	23.6	0.63	24.7	0.66
			20	1.4	15.1	0.40	30.9	0.83	31.5	0.84
			40	2.8	26.3	0.70	52.9	1.42	52.9	1.42
			60	4.1	36.0	0.96	72.3	1.94	72.3	1.94
			80	5.5	45.6	1.22	91.6	2.46	91.6	2.46
			100	6.9	55.2	1.48	111.0	2.98	111.0	2.98
			125	8.6	67.3	1.80	135.2	3.62	135.2	3.62
	150	10.3	79.3	2.12	159.3	4.27	159.3	4.27		
	20	1.4	25	1.7	28.5	0.76	31.2	0.84	33.2	0.89
			30	2.1	37.1	0.99	38.8	1.04	40.1	1.08
			40	2.8	50.4	1.35	51.2	1.37	51.9	1.39
			60	4.1	72.0	1.93	72.2	1.94	72.3	1.94
			80	5.5	91.6	2.46	91.6	2.46	91.6	2.46
			100	6.9	111.0	2.98	111.0	2.98	111.0	2.98
125			8.6	135.2	3.62	135.2	3.62	135.2	3.62	
150	10.3	159.3	4.27	159.3	4.27	159.3	4.27			
16 to 30 psig / 1.1 to 2.1 bar  10C1240X012  Red	20	1.4	25	1.7	17.2	0.46	31.2	0.84	33.2	0.89
			30	2.1	22.1	0.59	38.8	1.04	40.1	1.08
			40	2.8	29.8	0.80	51.2	1.37	51.9	1.39
			60	4.1	42.5	1.14	72.2	1.94	72.3	1.94
			80	5.5	54.1	1.45	91.6	2.46	91.6	2.46
			100	6.9	65.5	1.76	111.0	2.98	111.0	2.98
			125	8.6	79.8	2.14	135.2	3.62	135.2	3.62
	150	10.3	94.0	2.52	159.3	4.27	159.3	4.27		
	30	2.1	35	2.4	34.4	0.92	38.7	1.04	41.8	1.12
			40	2.8	38.4	1.03	46.6	1.25	48.8	1.31
			60	4.1	61.2	1.64	71.0	1.90	71.6	1.92
			80	5.5	79.7	2.14	91.5	2.45	91.6	2.46
			100	6.9	96.9	2.60	111.0	2.98	111.0	2.98
			125	8.6	118.0	3.16	135.2	3.62	135.2	3.62
150			10.3	139.1	3.73	159.3	4.27	159.3	4.27	

1. Outlet pressure setting was made at approximately 10% of the maximum capacity for the listed conditions.  
 Gray areas indicate maximum flow capacity.

- continued -

# Bulletin 71.1:133

**Table 9. Type 133HP Regulator 40% Capacities in Thousands of SCFH of 0.6 Specific Gravity Gas at 14.7 psia and 60°F (continued)**

OUTLET PRESSURE RANGE, CONTROL SPRING NUMBER, AND COLOR	OUTLET PRESSURE SETTING <sup>(1)</sup>		INLET PRESSURE		2-INCH / DN 50 BODY SIZE 1.91-INCH / 48.5 mm ORIFICE SIZE					
					Droop from Setpoint					
					10%		20%		30%	
					psig	bar	psig	bar	SCFH	Nm <sup>3</sup> /h
26 to 40 psig / 1.8 to 2.8 bar  10C1241X012  Blue	30	2.1	35	2.4	19.7	0.53	38.7	1.04	41.8	1.12
			40	2.8	24.6	0.66	46.6	1.25	48.8	1.31
			60	4.1	39.0	1.04	71.0	1.90	71.6	1.92
			80	5.5	50.7	1.36	91.5	2.45	91.6	2.46
			100	6.9	61.6	1.65	111.0	2.98	111.0	2.98
			125	8.6	75.0	2.01	135.2	3.62	135.2	3.62
			150	10.3	88.4	2.37	159.3	4.27	159.3	4.27
	40	2.8	45	3.1	30.3	0.81	46.2	1.24	50.4	1.35
			50	3.4	37.1	0.99	54.3	1.46	57.4	1.54
			60	4.1	48.0	1.29	67.8	1.82	69.7	1.87
			80	5.5	65.6	1.76	90.5	2.42	91.2	2.44
			100	6.9	80.9	2.17	110.9	2.97	111.0	2.98
			125	8.6	98.9	2.65	135.2	3.62	135.2	3.62
			150	10.3	116.6	3.12	159.3	4.27	159.3	4.27
36 to 50 psig / 2.5 to 3.4 bar  10C1242X012  Green	40	2.8	45	3.1	24.6	0.66	46.2	1.24	50.4	1.35
			50	3.4	30.0	0.80	54.3	1.46	57.4	1.54
			60	4.1	38.8	1.04	67.8	1.82	69.7	1.87
			80	5.5	52.9	1.42	90.5	2.42	91.2	2.44
			100	6.9	65.3	1.75	110.9	2.97	111.0	2.98
			125	8.6	79.8	2.14	135.2	3.62	135.2	3.62
			150	10.3	94.0	2.52	159.3	4.27	159.3	4.27
	50	3.4	55	3.8	34.8	0.93	53.7	1.44	59.0	1.58
			60	4.1	41.8	1.12	61.9	1.66	66.0	1.77
			80	5.5	62.9	1.69	88.1	2.36	89.8	2.41
			100	6.9	79.7	2.14	110.0	2.95	110.7	2.97
			125	8.6	98.7	2.64	135.2	3.62	135.2	3.62
			150	10.3	116.6	3.12	159.3	4.27	159.3	4.27
			45 to 60 psig / 3.1 to 4.1 bar  10C1243X012  White	50	3.4	55	3.8	29.5	0.79	53.7
60	4.1	35.3				0.95	61.9	1.66	66.0	1.77
80	5.5	53.0				1.42	88.1	2.36	89.8	2.41
100	6.9	67.2				1.80	110.0	2.95	110.7	2.97
125	8.6	83.1				2.23	135.2	3.62	135.2	3.62
150	10.3	98.1				2.63	159.3	4.27	159.3	4.27
60	4.1	65				4.5	39.5	1.06	61.3	1.64
		70		4.8	46.7	1.25	69.5	1.86	74.6	2.00
		80		5.5	58.6	1.57	83.8	2.25	87.2	2.34
		100		6.9	77.8	2.08	108.0	2.89	109.6	2.94
		125		8.6	98.1	2.63	134.6	3.61	135.1	3.62
		150		10.3	116.8	3.13	159.3	4.27	159.3	4.27

1. Outlet pressure setting was made at approximately 10% of the maximum capacity for the listed conditions.  
 Gray areas indicate maximum flow capacity.

Table 10. Type 133HP Regulator 60% Capacities in Thousands of SCFH of 0.6 Specific Gravity Gas at 14.7 psia and 60°F

OUTLET PRESSURE RANGE, CONTROL SPRING NUMBER, AND COLOR	OUTLET PRESSURE SETTING <sup>(1)</sup>		INLET PRESSURE		2-INCH / DN 50 BODY SIZE 1.91-INCH / 48.5 mm ORIFICE SIZE					
					Droop from Setpoint					
	psig	bar	psig	bar	10%		20%		30%	
					SCFH	Nm <sup>3</sup> /h	SCFH	Nm <sup>3</sup> /h	SCFH	Nm <sup>3</sup> /h
2 to 5 psig / 0.14 to 0.34 bar  17B8632X012  Yellow	2	0.14	10	0.69	9.1	0.24	17.7	0.47	26.4	0.71
			20	1.4	14.5	0.39	28.3	0.76	42.1	1.13
			40	2.8	24.2	0.65	47.1	1.26	70.0	1.88
			60	4.1	33.5	0.90	65.2	1.75	96.9	2.60
			80	5.5	42.6	1.14	83.0	2.22	123.4	3.31
			100	6.9	51.8	1.39	100.8	2.70	149.8	4.02
			125	8.6	63.2	1.69	122.9	3.29	182.7	4.90
	150	10.3	74.5	2.00	145.0	3.89	215.6	5.78		
	5	0.34	10	0.69	18.8	0.50	26.1	0.70	27.0	0.72
			20	1.4	33.6	0.90	45.7	1.22	46.1	1.24
			40	2.8	57.8	1.55	78.4	2.10	78.5	2.10
			60	4.1	80.5	2.16	109.1	2.92	109.2	2.93
			80	5.5	102.9	2.76	139.4	3.74	139.4	3.74
			100	6.9	125.1	3.35	169.4	4.54	169.4	4.54
125			8.6	152.7	4.09	206.7	5.54	206.8	5.54	
150	10.3	180.2	4.83	244.0	6.54	244.0	6.54			
4.5 to 10 psig / 0.31 to 0.69 bar  17B8633X012  Orange	5	0.34	10	0.69	10.0	0.27	20.0	0.54	27.0	0.72
			20	1.4	17.7	0.47	34.8	0.93	46.1	1.24
			40	2.8	30.4	0.82	59.5	1.60	78.5	2.10
			60	4.1	42.3	1.13	82.9	2.22	109.2	2.93
			80	5.5	54.0	1.45	105.8	2.84	139.4	3.74
			100	6.9	65.7	1.76	128.6	3.45	169.4	4.54
			125	8.6	80.1	2.15	157.0	4.21	206.8	5.54
	150	10.3	94.6	2.54	185.2	4.96	244.0	6.54		
	10	0.69	25	1.7	38.3	1.03	51.2	1.40	52.1	1.40
			30	2.1	45.1	1.21	60.0	1.63	60.7	1.63
			40	2.8	57.8	1.55	76.6	2.07	77.1	2.07
			60	4.1	81.8	2.19	108.0	2.90	108.3	2.90
			80	5.5	105.1	2.82	138.6	3.72	138.8	3.72
			100	6.9	128.0	3.43	168.8	4.53	168.9	4.53
125			8.6	156.5	4.19	206.3	5.53	206.4	5.53	
150	10.3	184.9	4.96	243.7	6.53	243.8	6.53			
6 to 20 psig / 0.41 to 1.4 bar  10C1238X012  Silver	10	0.69	15	1.0	14.6	0.39	31.1	0.83	32.7	0.88
			20	1.4	20.0	0.54	41.8	1.12	42.9	1.15
			40	2.8	37.3	1.00	76.6	2.05	77.1	2.07
			60	4.1	52.7	1.41	108.0	2.89	108.3	2.90
			80	5.5	67.7	1.81	138.6	3.71	138.8	3.72
			100	6.9	82.5	2.21	168.8	4.52	168.9	4.53
			125	8.6	100.8	2.70	206.3	5.53	206.4	5.53
	150	10.3	119.1	3.19	243.7	6.53	243.8	6.53		
	20	1.4	25	1.7	36.9	0.99	40.9	1.10	44.2	1.18
			30	2.1	49.2	1.32	52.0	1.39	54.5	1.46
			40	2.8	69.2	1.86	71.1	1.90	72.7	1.95
			60	4.1	103.6	2.78	104.7	2.81	105.7	2.83
			80	5.5	135.5	3.63	136.3	3.65	136.9	3.67
			100	6.9	166.5	4.46	167.0	4.48	167.6	4.49
125			8.6	204.6	5.48	205.0	5.49	205.4	5.50	
150	10.3	242.3	6.49	242.7	6.50	243.0	6.51			
16 to 30 psig / 1.1 to 2.1 bar  10C1240X012  Red	20	1.4	25	1.7	22.0	0.59	40.9	1.10	44.2	1.18
			30	2.1	28.9	0.78	52.0	1.39	54.5	1.46
			40	2.8	40.5	1.08	71.1	1.90	72.7	1.95
			60	4.1	60.4	1.62	104.7	2.81	105.7	2.83
			80	5.5	78.9	2.12	136.3	3.65	136.9	3.67
			100	6.9	96.9	2.60	167.0	4.48	167.6	4.49
			125	8.6	119.0	3.19	205.0	5.49	205.4	5.50
	150	10.3	141.0	3.78	242.7	6.50	243.0	6.51		
	30	2.1	35	2.4	39.1	1.05	50.7	1.36	55.7	1.49
			40	2.8	50.1	1.34	62.1	1.66	66.0	1.77
			60	4.1	84.3	2.26	99.7	2.67	101.8	2.73
			80	5.5	113.6	3.04	132.8	3.56	134.3	3.60
			100	6.9	141.2	3.78	164.5	4.41	165.6	4.44
			125	8.6	174.8	4.68	203.1	5.44	203.9	5.46
150			10.3	207.9	5.57	241.2	6.46	241.8	6.48	

1. Outlet pressure setting was made at approximately 10% of the maximum capacity for the listed conditions.  
 Gray areas indicate maximum flow capacity.

- continued -

# Bulletin 71.1:133

**Table 10. Type 133HP Regulator 60% Capacities in Thousands of SCFH of 0.6 Specific Gravity Gas at 14.7 psia and 60°F (continued)**

OUTLET PRESSURE RANGE, CONTROL SPRING NUMBER, AND COLOR	OUTLET PRESSURE SETTING <sup>(1)</sup>		INLET PRESSURE		2-INCH / DN 50 BODY SIZE 1.91-INCH / 48.5 mm ORIFICE SIZE					
					Droop from Setpoint					
					10%		20%		30%	
	psig	bar	psig	bar	SCFH	Nm <sup>3</sup> /h	SCFH	Nm <sup>3</sup> /h	SCFH	Nm <sup>3</sup> /h
26 to 40 psig / 1.8 to 2.8 bar  10C1241X012  Blue	30	2.1	35	2.4	25.0	0.67	50.7	1.36	55.7	1.49
			40	2.8	31.9	0.86	62.1	1.66	66.0	1.77
			60	4.1	53.4	1.43	99.7	2.67	101.8	2.73
			80	5.5	71.9	1.93	132.8	3.56	134.3	3.60
			100	6.9	89.3	2.39	164.5	4.41	165.6	4.44
			125	8.6	110.5	2.96	203.1	5.44	203.9	5.46
			150	10.3	131.4	3.52	241.2	6.46	241.8	6.48
	40	2.8	45	3.1	38.5	1.03	60.5	1.62	67.1	1.80
			50	3.4	48.0	1.29	72.1	1.93	77.5	2.08
			60	4.1	63.9	1.71	92.5	2.48	96.4	2.58
			80	5.5	90.8	2.43	128.1	3.43	130.7	3.50
			100	6.9	115.0	3.08	161.0	4.32	162.9	4.37
			125	8.6	144.0	3.86	200.5	5.37	201.9	5.41
			150	10.3	172.1	4.61	239.1	6.41	240.2	6.44
36 to 50 psig / 2.5 to 3.4 bar  10C1242X012  Green	40	2.8	45	3.1	31.2	0.84	60.5	1.62	67.1	1.80
			50	3.4	38.8	1.04	72.1	1.93	77.5	2.08
			60	4.1	51.5	1.38	92.5	2.48	96.4	2.58
			80	5.5	73.1	1.96	128.1	3.43	130.7	3.50
			100	6.9	92.6	2.48	161.0	4.32	162.9	4.37
			125	8.6	115.8	3.10	200.5	5.37	201.9	5.41
			150	10.3	138.5	3.71	239.1	6.41	240.2	6.44
	50	3.4	55	3.8	44.2	1.18	70.3	1.88	78.6	2.11
			60	4.1	53.9	1.44	82.1	2.20	89.0	2.38
			80	5.5	84.8	2.27	121.7	3.26	125.9	3.37
			100	6.9	110.9	2.97	156.4	4.19	159.4	4.27
			125	8.6	140.9	3.78	197.1	5.28	199.3	5.34
			150	10.3	169.7	4.55	236.5	6.34	238.2	6.38
			45 to 60 psig / 3.1 to 4.1 bar  10C1243X012  White	50	3.4	55	3.8	37.3	1.00	70.3
60	4.1	45.4				1.22	82.1	2.20	89.0	2.38
80	5.5	71.4				1.91	121.7	3.26	125.9	3.37
100	6.9	93.2				2.50	156.4	4.19	159.4	4.27
125	8.6	118.4				3.17	197.1	5.28	199.3	5.34
150	10.3	142.6				3.82	236.5	6.34	238.2	6.38
60	4.1	65				4.5	50.0	1.34	80.1	2.15
		70		4.8	59.9	1.60	92.0	2.47	100.5	2.69
		80		5.5	77.0	2.06	113.2	3.03	119.8	3.21
		100		6.9	105.8	2.84	150.5	4.03	155.0	4.15
		125		8.6	137.5	3.68	192.9	5.17	196.2	5.26
		150		10.3	167.4	4.49	233.2	6.25	235.8	6.32

1. Outlet pressure setting was made at approximately 10% of the maximum capacity for the listed conditions.  
 Gray areas indicate maximum flow capacity.

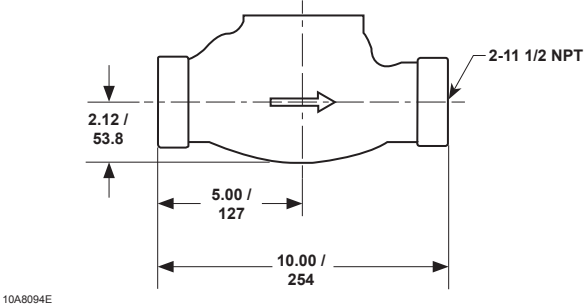
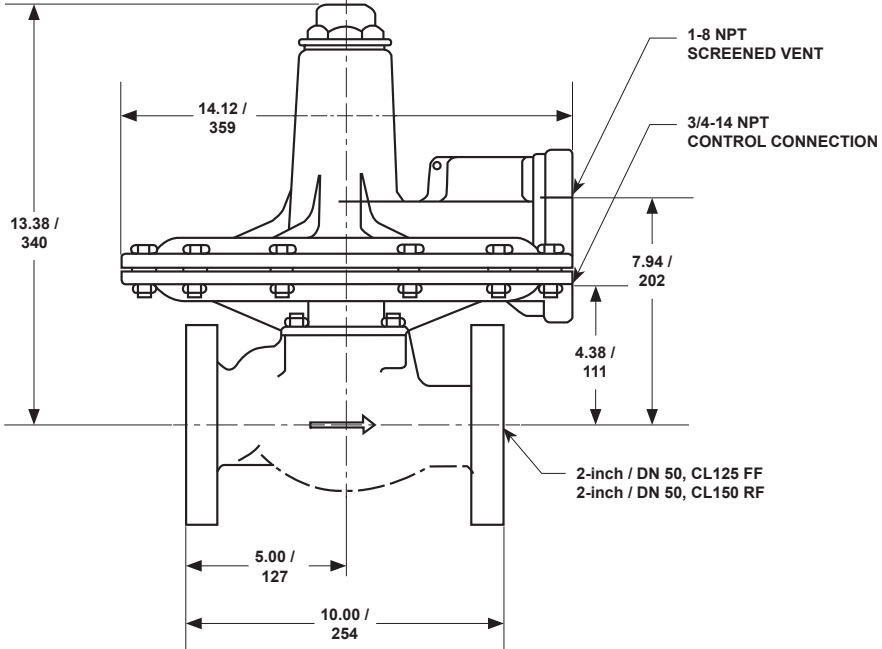

10A8094E

Inch /  
mm

TYPES 133H, 133L, AND 133Z REGULATOR

Figure 9. Dimensions

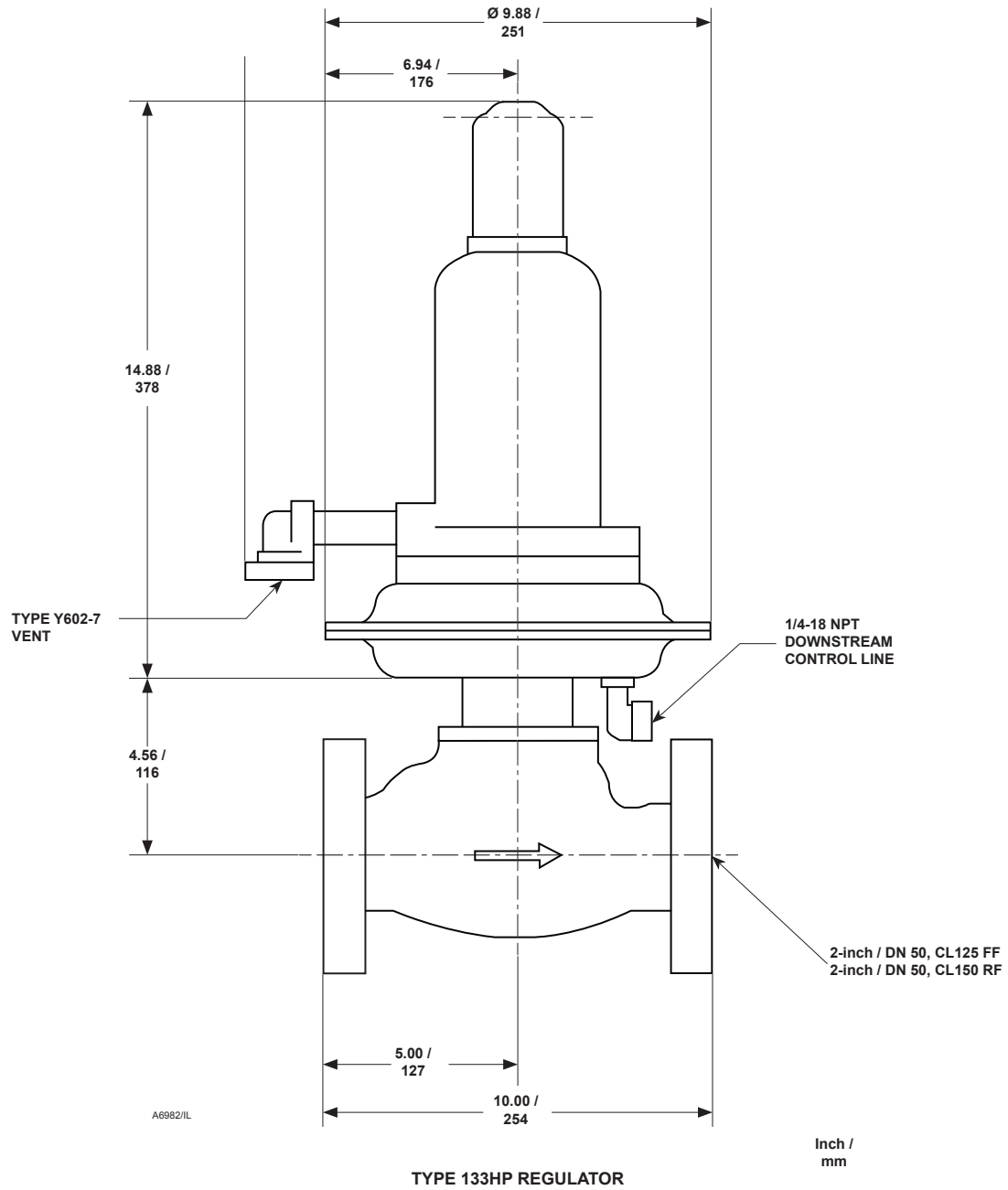

Figure 9. Dimensions (continued)

## Ordering Information

Use the Specifications section on page 2 and carefully review the description to the right of each specification. Use this information to complete the Ordering Guide

on the following page. Specify the desired selection wherever there is a choice to be made. Then send the Ordering Guide to your local Sales Office.

## Ordering Guide

### Type (Select One)

- 133L
- 133H
- 133Z
- 133HP

### Body Material and End Connection Style (Select One)

#### Cast Iron

- NPT
- CL125 FF

#### Steel

- NPT
- CL150 RF

### Outlet Pressure Range (Select One)

#### Type 133L or 133H

- 2 to 4 inches w.c. / 5 to 10 mbar, Brown
- 3.5 to 6 inches w.c. / 9 to 15 mbar, Red
- 5 to 9 inches w.c. / 12 to 22 mbar, Black
- 8.5 to 18 inches w.c. / 21 to 45 mbar, White
- 14 to 28 inches w.c. / 35 to 70 mbar, Green
- 0.75 to 2 psig / 52 mbar to 0.14 bar, Blue

#### Type 133H

- 1.5 to 3 psig / 0.10 to 0.21 bar, Orange
- 2 to 5 psig / 0.14 to 0.34 bar, Yellow
- 5 to 10 psig / 0.34 to 0.69 bar, Blue

#### Type 133Z

- 1 to 1 inch w.c. / -2 to 2 mbar, Unpainted
- 0 to 4 inch w.c. / 0 to 10 mbar, Brown

### Type 133HP

- 2 to 5 psig / 0.14 to 0.34 bar, Yellow
- 4.5 to 10 psig / 0.31 to 0.69 bar, Orange
- 6 to 20 psig / 0.41 to 1.4 bar, Silver
- 16 to 30 psig / 1.1 to 2.1 bar, Red
- 26 to 40 psig / 1.8 to 2.8 bar, Blue
- 36 to 50 psig / 2.5 to 3.4 bar, Green
- 45 to 60 psig / 3.1 to 4.1 bar, White

### Trim, Percent of Full Capacity (Select One)

- 100 percent (**standard**)
- 60 percent
- 40 percent
- 25 percent

### Elastomers (Select One)

- Nitrile (NBR) (**standard**)
- Fluorocarbon (FKM)  
(Available for Types 133L and 133H only)

### Body Position (refer to Figure 8) (Select One)

- Position 1 (**standard**)
- Position 2
- Position 3
- Position 4

### Vent Position (refer to Figure 8) (Select One)

- Position C (**standard** for Type 133HP)
- Position D
- Position E (**standard** for Types 133L, 133H, and 133Z)
- Position F

Regulators Quick Order Guide	
***	Readily Available for Shipment
**	Allow Additional Time for Shipment
*	Special Order, Constructed from Non-Stocked Parts. Consult your local Sales Office for Availability.
Availability of the product being ordered is determined by the component with the longest shipping time for the requested construction.	

**Specification Worksheet**

**Application:**  
 Specific Use \_\_\_\_\_  
 Line Size \_\_\_\_\_  
 Fluid Type \_\_\_\_\_  
 Specific Gravity \_\_\_\_\_  
 Temperature \_\_\_\_\_  
 Does the Application Require Overpressure Protection?  
 Yes     No

**Pressure:**  
 Maximum Inlet Pressure ( $P_{1max}$ ) \_\_\_\_\_  
 Minimum Inlet Pressure ( $P_{1min}$ ) \_\_\_\_\_  
 Downstream Pressure Setting(s) ( $P_2$ ) \_\_\_\_\_  
 Set Pressure \_\_\_\_\_  
 Maximum Flow ( $Q_{max}$ ) \_\_\_\_\_

**Accuracy Requirements:**  
 Less Than or Equal To:  
 5%     10%     20%     40%

**Construction Material Requirements (if known):**  
 \_\_\_\_\_  
 \_\_\_\_\_

**Industrial Regulators**

Emerson Process Management  
Regulator Technologies, Inc.

**Natural Gas Technologies**

Emerson Process Management

**TESCOM**

Emerson Process Management

For further information visit [www.emersonprocess.com/regulators](http://www.emersonprocess.com/regulators)

The Emerson logo is a trademark and service mark of Emerson Electric Co. All other marks are the property of their prospective owners. Fisher is a mark owned by Fisher Controls International LLC, a business of Emerson Process Management.

*The contents of this publication are presented for informational purposes only, and while every effort has been made to ensure their accuracy, they are not to be construed as warranties or guarantees, express or implied, regarding the products or services described herein or their use or applicability. We reserve the right to modify or improve the designs or specifications of such products at any time without notice.*

Emerson Process Management Regulator Technologies, Inc. does not assume responsibility for the selection, use or maintenance of any product. Responsibility for proper selection, use and maintenance of any Emerson Process Management Regulator Technologies, Inc. product remains solely with the purchaser.