

# SMARTLINK<sup>®</sup> METER

## Digital Self-checking Thermal Mass Flow Meter

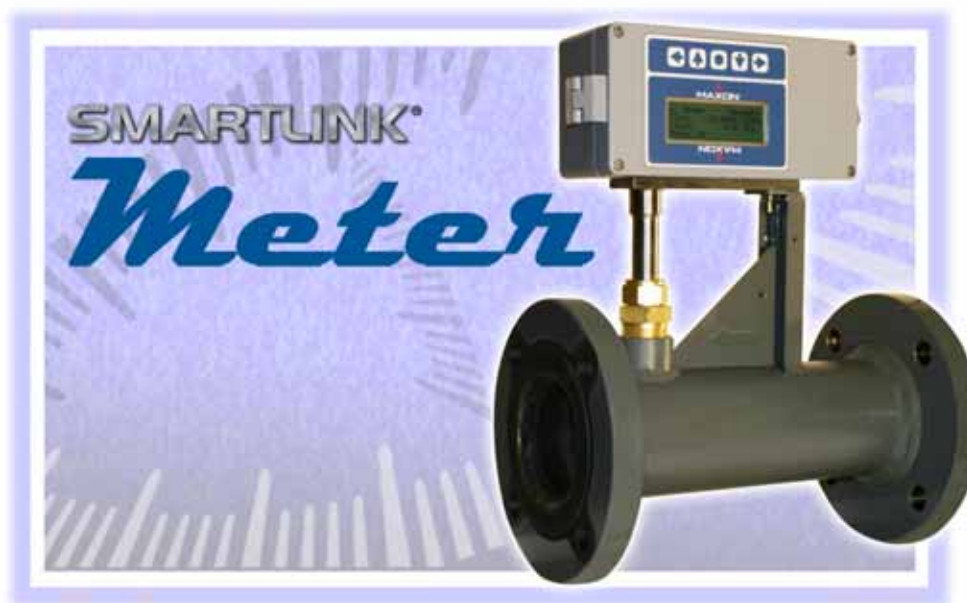

- Precise, repeatable mass flow measurement for fuel, air and combustion streams
- Displays instantaneous standard rate and totalized flow without calculations
- Advanced calibration extends accuracy over wider ranges of fluid temperatures
- Thermal mass flow technology provides reliable measurements with no moving parts
- Provides excellent accuracy over a wide turndown range
- Redundancy and an alarm output for “on-line” self-checking and fail-safe operation
- Monitors, displays, and outputs air/fuel ratio when two meters are electrically “linked”
- Viewable flow totalizer without batteries or external equipment
- In-line flow body incorporates conditioning screens to reduce straight-run piping requirements, eliminating many installation problems common to insertion type meters
- Large, convenient local display for ease of use. No PC or other interface necessary for configuration and operation
- Fail-safe alarm, limit and analog outputs for easy integration into PLC or DCS systems
- Factory Mutual (FM) approved for Hazardous Locations, Class I, II Division 2, Groups A, B, C, D, E, F, G and Class I, Zone 2, Group IIC
- ATEX and IEC Ex hazardous location approval

## Product overview

SMARTLINK® METER is a highly accurate and repeatable mass flow meter well suited for monitoring fuel and air. The meter is built with a rugged NEMA 4X (IP66) enclosure for industrial applications. The design is based on a well established thermal mass flow sensing principle and innovative electronics that provide many self-checking functions to ensure measurement integrity.

The meter uses a constant temperature differential ( $\Delta T$ ) technique with two matched, platinum RTD (Resistive Temperature Device) elements in a rugged, stainless probe assembly. One RTD measures fluid temperature and an "intelligent" bridge circuit heats the second RTD element, maintaining a constant temperature differential above the temperature of the process fluid. Based on the amount of power delivered to the heated element, the precise mass flow rate is established by the on-board microprocessor. The highly integrated sensor probe and electronic design permits fully automated factory calibration, providing every manufactured unit with out-of-the-box measurement accuracy.

SMARTLINK® METER incorporates an input/output (I/O) module with analog 4-20mA current loops for monitoring flow and air/fuel ratio or fluid temperature. A redundant system design is employed for "on-line" flow meter test functions and fail-safe alarm, limit, and test status indication. A liquid crystal display (LCD) and a membrane switch keypad provide easy meter configuration and local viewing of meter status. Each unit is calibrated for air or natural gas and includes an "in-line" flow body that conditions the fluid velocity profile and sets the depth of the probe assembly for proper measurement in the flow stream.

## Available SMARTLINK® METER models and sizes

In-line natural gas meters				
Model number	Nominal flow body size (mm)	Minimum flow (m <sup>3</sup> (st)/h) [1]	Maximum flow (m <sup>3</sup> (st)/h) [1]	Max DP @ STP [1] [2] (mbar)
0200 SLM	51	4.53	227	25
0300 SLM	76	10.2	510	25
0400 SLM	102	18.1	906	28
0600 SLM	152	42.4	2124	27

[1] STP (Standard Temperature and Pressure) conditions for m<sup>3</sup>(st)/h (cubic meters per hour) units are 15.56°C and 1016 mbar

[2] Stated differential pressures (DP) assume STP conditions and the maximum rated in-line meter flow rate with a natural gas density of 0.680 kg/m<sup>3</sup>.

In-line air meters				
Model number	Nominal flow body size (mm)	Minimum flow (m <sup>3</sup> (st)/h) [1]	Maximum flow (m <sup>3</sup> (st)/h) [1]	Max DP @ STP [1] [2] (mbar)
0800 SLM	203	79.3	3964	30
1200 SLM	305	176	8778	30
1600 SLM	406	275	13733	29
2000 SLM	508	425	21238	28
2400 SLM	610	623	31149	29
2800 SLM	711	850	42475	29

[1] STP (Standard Temperature and Pressure) conditions for m<sup>3</sup>(st)/h (cubic meters per hour) units are 15.56°C and 1016 mbar

[2] Stated differential pressures (DP) assume STP conditions and the maximum in-line meter flow rate with an air density of 1.23 kg/m<sup>3</sup> and 25% RH (relative humidity)

## Typical applications

SMARTLINK<sup>®</sup> METER is a rugged, industrial instrument for use with natural gas and air. In addition to single stream combustion flows and totalization, SMARTLINK<sup>®</sup> METER can be installed in sets to monitor ratios or relative flows. With intelligent, self-monitoring features, the meter provides ease of use and enhanced information on processes.

Typical SMARTLINK<sup>®</sup> METER installations also may include:

- Measuring gas consumption on industrial furnaces, ovens, oxidizers, or process heaters, especially in facilities with multiple combustion systems on one gas company meter
- Checking or controlling air and fuel ratio to industrial burners for efficiency optimization
- Verifying or controlling air and fuel ratio to industrial burners for emissions compliance
- Monitoring air and fuel ratio for products sensitive to reducing atmospheres or oxidizing environments
- Measuring burner air and fuel flows for set-up and adjustment
- Monitoring critical gas flows to alarm maximum or minimum rates
- Measuring and monitoring relative rates of process gases or combustion gases for critical process heating appliances
- Verification of gas usage to identify optimization targets or to expose wasted fuel within in-plant piping and equipment

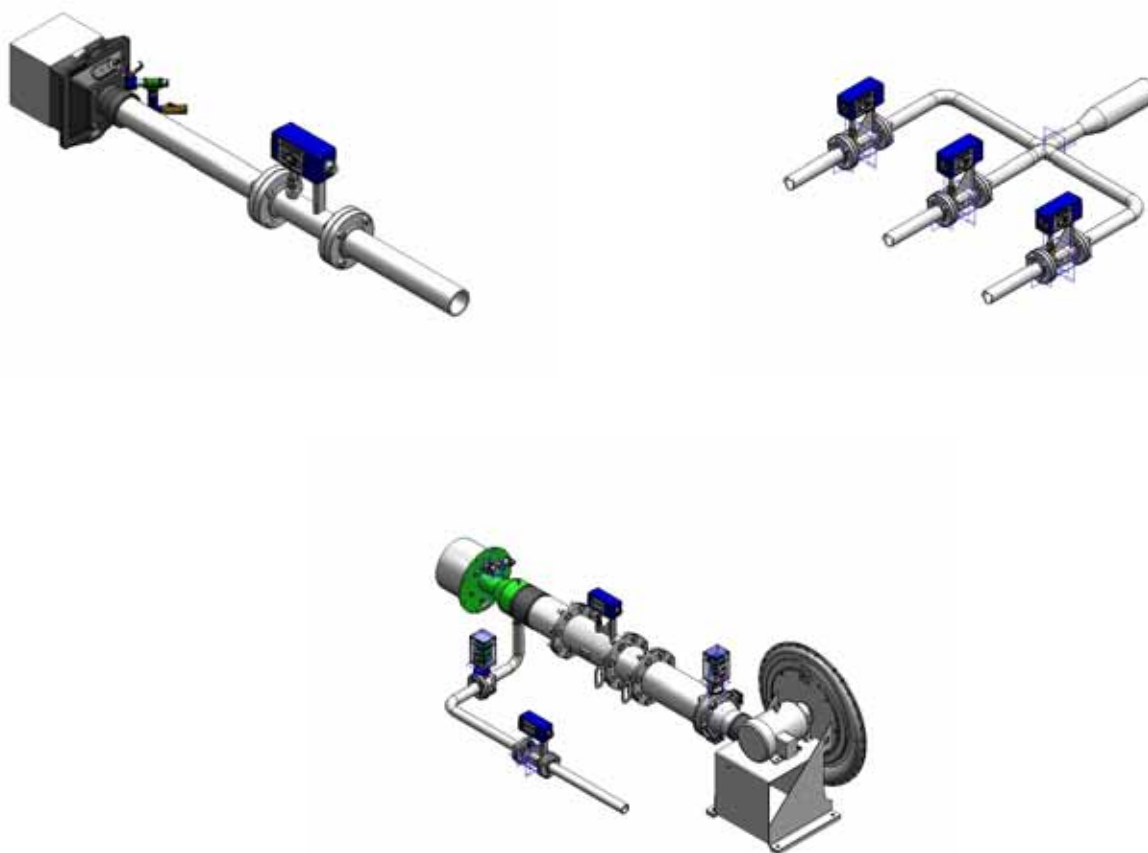

## Dimensions and weights

### Natural gas models

- 1) Over raised faces
- 2) Drawing of 0200 SLM only
- 3) Flow direction right to left

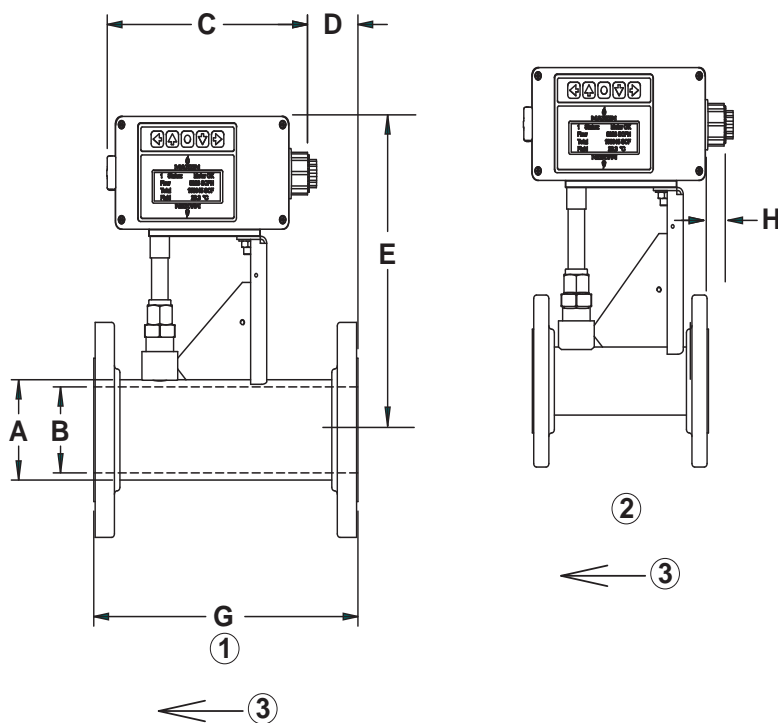

Dimensions in millimeters unless stated otherwise

Model	Nominal size	A	B	C	D	E	G	H	Approx. weight kg
0200 SLM	51	60	51	231	-	277	202	18	9
0300 SLM	76	89	76	231	58	277	305	-	15
0400 SLM	102	114	99	231	135	277	406	-	22
0600 SLM	152	168	152	231	287	300	610	-	38

Air models

- 1) Jack bolts
- 2) Over gaskets
- 3) Flow direction from right to left

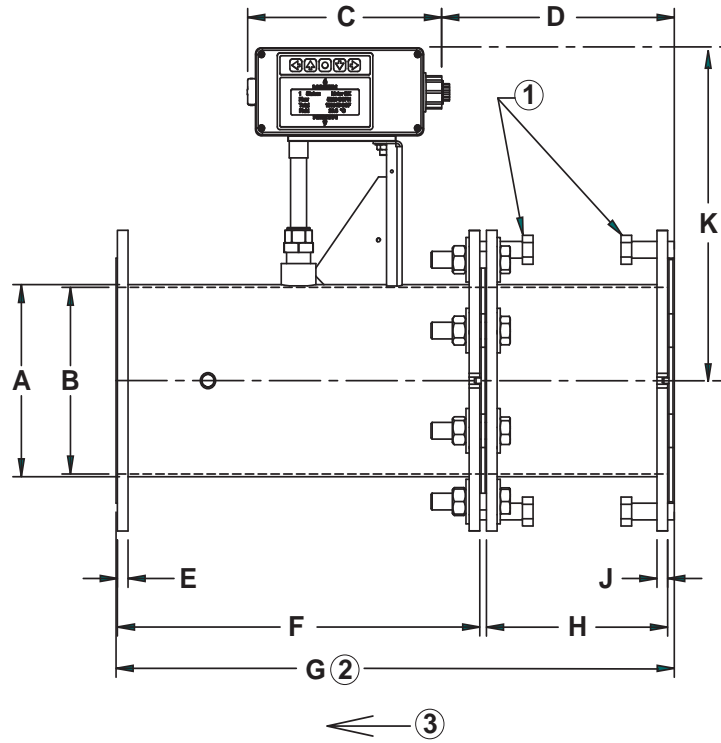

Dimensions in millimeters unless stated otherwise

Model	Nominal size	A	B	C	D	E	F	G	H	J	K	Approx. weight kg
0800 SLM	203	219	214	231	277	13	431	666	216	13	379	34
1200 SLM	305	324	319	231	408	13	635	970	318	13	379	64
1600 SLM	406	406	400	231	658	13	812	1237	406	13	417	102
2000 SLM	508	508	502	231	861	13	1016	1542	508	13	467	136
2400 SLM	610	610	604	231	1064	13	1219	1847	610	13	518	182
2800 SLM	711	711	705	231	1267	13	1219	1948	711	13	569	225