

July 2018

Description

Moore Industries' PC-Programmable Temperature Transmitters—the TRY (isolated) and TRX (non-isolated)—combine smart digital technology with advanced analog operation to deliver superior reliability, accuracy and ease of use.

Now with even more flexible capabilities, these 2-wire (loop-powered) analog/digital hybrid transmitters program in a minute or less to accept direct inputs from:

- **23 RTD Types**
(2-, 3-, and 4-wire; Pt, Cu and Ni; 10 to 1000 ohms)
- **9 Thermocouple Types**
(J, K, E, T, R, S, B, N, and C)
- **Direct Millivolt Sources**
(-50 to 1000mV)
- **Resistance & Potentiometer Devices**
(0 to 4000 ohms)

They convert the input to a highly accurate 4-20mA output that is both linear and scaleable with respect to the input—ready for direct interface with readout instruments, recorders, DCSes, and other computer-based SCADA systems.

Figure 1. Compact yet powerful, the 2-wire TRY and TRX transmitters afford full programmability in a rugged, ready-to-install assembly.

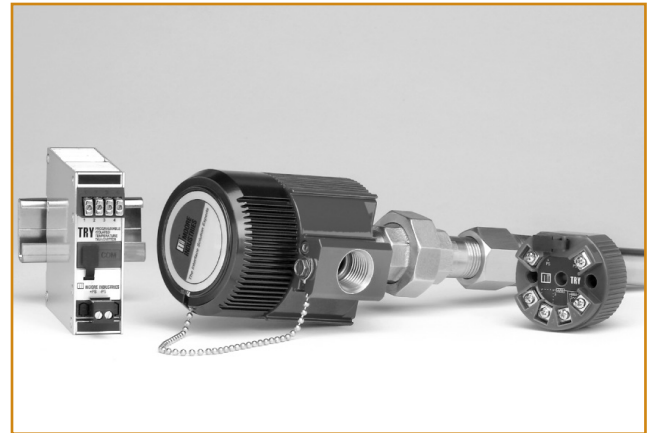
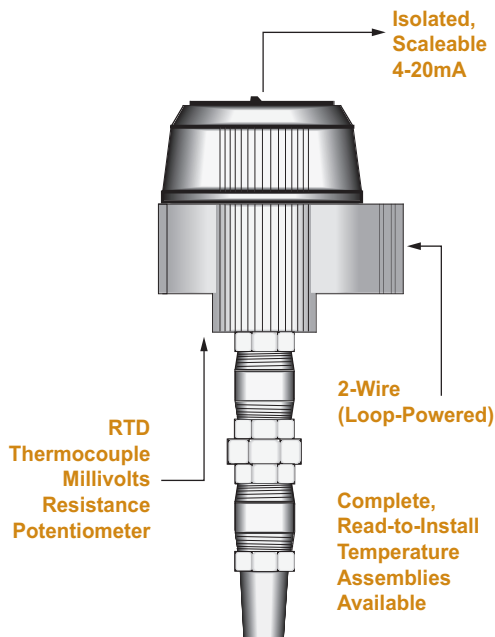

Available in a variety of housing styles, the TRY and TRX are ready to install in the control room, in existing hardware, or in their own, complete temperature assembly.

Features

- **Universal plant standard.** No need to specify and stock fixed range transmitters as spares. The TRY and TRX provide programmable input type and output scaling.
- **PC-programmable with Windows® software.** From a single screen, you can choose, and then view to confirm, all of your application-specific operating parameters from a personal computer.
- **Fast measurement cycle.** Delivering an output update up to 8 times per second, these transmitters are twice as fast as comparable microprocessor-based instruments.
- **Enhanced configuration software.** Now trim input sensor readings, and customize input linearization curves for even greater accuracy. Program output damping to compensate for erratic sensor readings. Use the Configuration Program to calibrate other loop instruments with its innovative Loop Test function.

Certifications



TRY & TRX

PC-Programmable
Temperature Transmitters

Universal Solution

With the TRY & TRX, there's no need to specify and stock an array of single-function instruments. They are the perfect solution:

- Convert RTD, T/C, mV, and ohm signals to the linear 4-20mA needed by an indicator, recorder, PC, PLC, DCS, or similar SCADA system.
- Easily customize linearization to process inputs in non-linear, millivolt input applications.
- Trim input readings directly from sensors to achieve maximum relative accuracy. Match performance characteristics with your already-installed hardware.
- Avoid inaccuracies that result from transmitting "weak", low-level sensor signals through a noisy plant by converting them to stable, high-level signals that can withstand long-distance transmission.
- Use true, 4-wire RTD inputs to eliminate signal inaccuracies that result from inevitable lead wire resistance imbalances.
- Increase DCS accuracy by using transmitters calibrated to a specific temperature range in place of direct DCS inputs that are only capable of measuring readings over the entire range of a sensor.
- Reduce installation costs by replacing expensive and fragile sensor wire runs and costly DCS input cards.
- Compensate for erratic input signals with programmable damping values.

Figure 2. The TRY delivers complete isolation to stop ground loops from affecting signal accuracy.

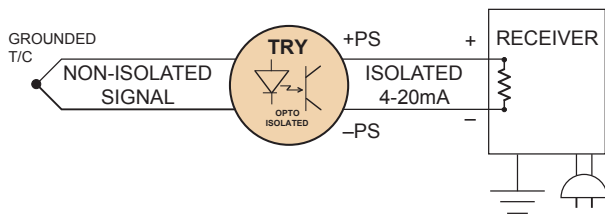

Total Sensor Diagnostics

Our programmable transmitters perform continuous sensor diagnoses. This industry-first, and patented, Moore Industries feature may save you thousands in production costs, and hours of troubleshooting time, by letting you know when a problem occurs, and its type and location.

Figure 3. Total Sensor Diagnostics saves troubleshooting time.

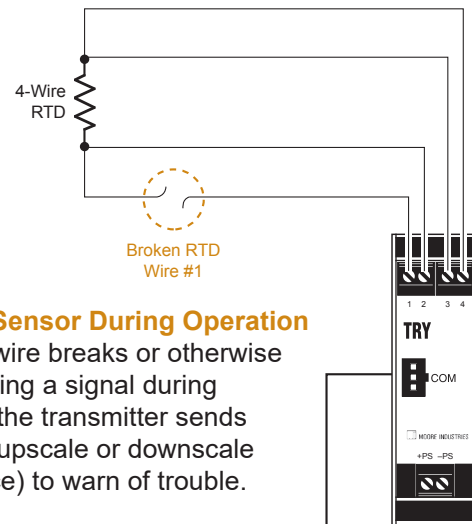

Monitors Sensor During Operation

If an RTD wire breaks or otherwise stops sending a signal during operation, the transmitter sends the output upscale or downscale (your choice) to warn of trouble.

Then our transmitters go a step further. By connecting your PC running the TRY/TRX Configuration Software to the instrument, the RTD wire(s) causing the problem are identified via a plain-English error message on the software window. Specific error messages eliminate the work of removing the sensor or checking all lead wires to diagnose a problem. This advantage is especially valuable during startup.

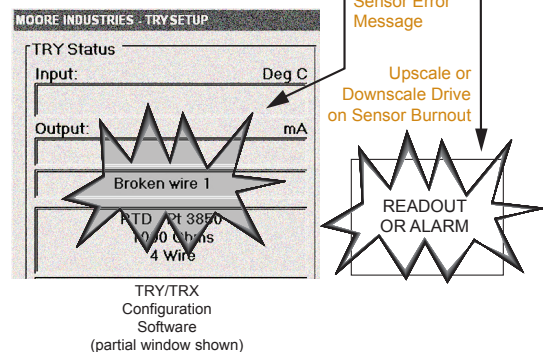

Intelligent Configuration Software

Configuring the TRY & TRX is as simple as point-and-click. Improved linearization and trimming capabilities make it an even more valuable tool.

All you need is a PC running Windows®, our TRY/TRX Configuration Software and a Configuration Cable (software supplied with each order).

In minutes, you can begin configuring your transmitter:

- Input type and range (zero and full scale)
- 4-20mA output range (zero and full scale)
- Reference junction compensation or no reference junction compensation for T/C inputs
- Linearization or no linearization
- Temperature readout in °F or °C
- 50Hz or 60Hz noise rejection
- Broken wire detection ON or OFF for calibration
- Upscale or downscale on sensor burnout
- Custom instrument tag (up to 40 characters) and instrument serial number
- Custom Input Linearization (up to 85 points)
- Custom Input Trimming to Actual Sensors
- Loop Test Fixed Output for Easy Calibration of other instruments in the Loop
- Damping Time for Erratic Signal Compensation (0-5 seconds)

Figure 4. All operating parameters can be set, and then viewed, on a single software screen.

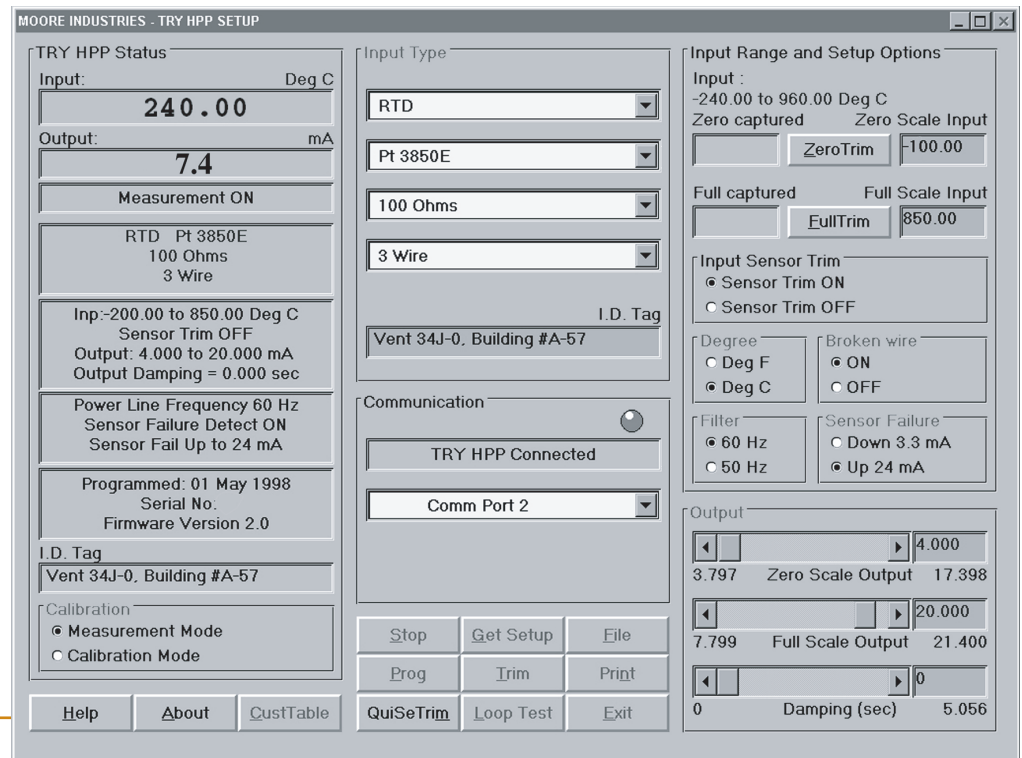

Trim to Specific Curve Segments

The TRY & TRX can be trimmed with two data points within the selected zero and span measurement range. This allows a complete process range to be monitored, while placing measurement emphasis on a critical segment of the range.

In the figure below, the ideal RTD curve is optimized between 20°C and 27°C to match the curve of the sensor used. This provides incredible precision over a limited portion of span, while measuring the remainder of the span with outstanding accuracy.

Figure 5. The TRY & TRX can be set to measure the segment most critical to the process.

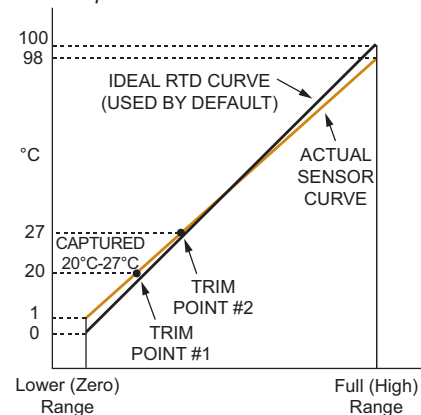

TRY & TRX

PC-Programmable
Temperature Transmitters

Specifications

Performance **Input Accuracy:** Refer to Table 1
Output Accuracy: 4.8µA (±0.03% of 4-20mA span)
Overall Accuracy: The overall accuracy of the unit is the combined input and output accuracy. It includes the combined effects of linearity, hysteresis, repeatability and adjustment resolution. It does not include ambient temperature effect. For T/C input only, add the Reference Junction Compensation error.
Reference Junction Compensation Accuracy: ±0.45°C
Stability: Error in Maximum Conformance Range

Stability	Input to Output		
	1 yr	3 yrs	5 yrs
T/C, mV	0.11	0.18	0.24
RTD Ohm Pot.	0.13	0.22	0.28

Isolation: For TRY in HPP housing, 1500Vrms input to output; For TRY in DIN housing, 500Vrms input to output to case
Measurement Cycle: Output updates 8 times per second
Response Time: 256msec typical for the output to change from 10% to 90% for an input step change of 0% to 100%
Step Response Time: 500msec typical from the time an input is applied until the output reaches 90% of its final value.
Ripple: 10mV peak-to-peak, max.
Power Supply and Load Effect: Negligible within power and load limits

Performance (Continued) **Over-Voltage Protection:** 4V, max, on input; 48V, max, on output; 48V reverse polarity
Load Capability: 500 ohms @ 24V, typical;

For TRY & TRX DIN:

$$\frac{(\text{Supply Voltage} - 10\text{V})}{0.024\text{A}}$$

For TRX HPP:

$$\frac{(\text{Supply Voltage} - 8\text{V})}{0.024\text{A}}$$

Burnout Protection: Total Sensor Diagnostics user-selected via Windows configuration software; Upscale to 24mA or downscale to 3.3mA
Output Current Limiting: 21.4mA for input overrange; 23.6mA for sensor failure or broken wire
T/C Input Impedance: 40M ohms, nominal
RTD Excitation: 250µA, ±10%
RTD Lead Wire Resistance Maximum: RTD resistance + 2 times the lead wire resistance must be less than 4000 ohms; Recommend <35 ohms per wire for 3-wire RTD inputs; <5 ohms per wire for 10 ohms Cu inputs

Ambient Conditions **Operating & Storage Range:** -40°C to +85°C (-40°F to +185°F)
Relative Humidity: 0-95%, non-condensing
Effect of Ambient Temperature on Accuracy: ±0.015% of span/°C change, max. (+0.001% of ohms reading for RTD inputs)
Effect of Ambient Temperature on Reference Junction Compensation: ±0.015°C/°C change
RFI/EMI Immunity: 20V/m @ 20-1000MHz, when tested according to SAMA standard 33.1. (10V/m @ 80-1000MHz, 1K AM, when tested according to IEC 1000-4-3-1995)
Common Mode Rejection: 100dB, min., @ 50/60Hz
Normal Mode Rejection: 100dB, typical, @ 1V peak-to-peak, 50/60Hz

Adjustments All settings made using Windows®-based configuration program, then stored in non-volatile memory

Weight **HPP-style housing:** 65g (2.3 oz)
DIN-style housing: 184g (6.5 oz)
LH housing styles: 549 g (19.4 oz)

Accessories

Each TRY and TRX order comes with one copy of our Configuration Software (Windows® compatible).

To order additional software or cables use chart.

Part Number	Part
750-75E05-01	Intelligent PC Configuration Software
803-039-26	Isolated Serial Configuration Cable
803-040-26	Non-Isolated Serial Configuration Cable
804-030-26	Fuse Protected USB Communication Cable (required by ATEX for products installed in Intrinsically-Safe areas)

Ordering Information

Unit	Input	Output	Power	Options	Housing
TRY Isolated, PC- Program- mable Temperature Transmitter	PRG Program- mable with supplied Configura- tion Software (see Table 1 for descrip- tions of available input types; Factory Con- figuration available)	4-20MA User scaleable with supplied software	10-42DC 10-30DC Required for -ISA, -ISC, -ISE and -ISF options (IS option not available with [DIN] housing)	-ISA TestSafe approved IS (ANZEx) -ISC (**) CSA approved IS and NI -ISE (**) ATEX approved IS -ISF (**) FM approved IS and NI -FMEDA Unit comes with Failure Modes, Effects and Diagnostic Analysis (FMEDA) data for evaluating the instrument for suitability of use in a safety-related application (TRY Only)	DIN DIN-style aluminum housing mounts on 32mm G-type (EN50035) and 35mm Top Hat (EN50022) rails HPP Hockey-puck housing for mounting in standard connection heads LH1NS‡ Aluminium IP 66 connection head with two entry ports: ½-inch NPT cable and process-black polycarbonate cover LH1MS‡ Aluminium IP 66 connection head with two entry ports: M20 cable and ½-inch NPT process-black polycarbonate cover LH1CS‡ Aluminium IP 66 connection head with two entry ports: M20 cable and G½ (BSP) process-black polycarbonate cover LH1NX Aluminium IP 66 connection head with ½-inch NPT entry and mounting plate for customer's air duct opening-black polycarbonate cover LH2NS(*) or (‡) Aluminum Explosion-proof/Flameproof connection head with two entry ports: ½-inch NPT cable and process-black metal cover LH2MS(*) or (‡) Aluminum Explosion-proof/Flameproof connection head with two entry ports: M20 cable and ½-inch NPT process-black metal cover
TRX Non- Isolated, PC- Program- mable Temperature Transmitter	PRG Program- mable with supplied Configura- tion Software (see Table 1 for descrip- tions of available input types; Factory Con- figuration available)	4-20MA User scaleable with supplied software	8-42DC 8-30DC Required for -ISA, -ISC, -ISE, and -ISF options (IS option not available with [DIN] housing) 10-42DC (DIN housing ONLY)		

* Either A or E suffix (comes supplied with 2" pipe mount hardware)
A suffix indicates ANZEx/TestSafe (Ex d)
Flameproof approvals (i.e. BH2MGA)
E suffix indicates ATEX (Ex d and tb) Flameproof approvals (i.e. BH2MGE)
** IS option not available with [DIN] housing
‡ P suffix indicates enclosure comes equipped with base plate and U-bolts for mounting on a 2-inch pipe (i.e. BH2NGP)
See BH, SB and D-BOX Datasheets for additional information.

When Ordering, specify: Unit/Input/Output/Power/Option(s) [Housing]
Model number example: TRY/PRG/4-20MA/10-30DC-ISF [LH2MSP]

Certifications



TRY [DIN]
CSA Group (Canadian Standards Association):
General/Ordinary Location



TRX [HPP] or TRY [HPP]
FM Global Group (FM Approvals):
Intrinsically-Safe
Class I, II & III Division 1, Groups A thru G
Class I, Zone 0, AEx ia IIC T6 Ta = +60°C
Non-Incendive
Class I, Division 2, Groups A, B, C & D
Suitable for:
Class II & III, Division 2, Groups F and G
Temperature Class T6 @ 60°C Ambient



CSA Group (Canadian Standards Association):
General/Ordinary Location
Intrinsically-Safe
Class I, Division 1, Groups A, B, C & D
Non-Incendive
Class I, Division 2, Groups A, B, C & D
Temperature Code T6 @ 60°C Ambient



ATEX Directive 2014/34/EU (LCIE):
Intrinsically-Safe
⊕ II 2G EEx ib IIB T6 Ta = +60°C (TRX)
⊕ II 2G EEx ib IIC T6 Ta = +60°C (TRY)
Temperature Code T6 @ 60°C Ambient

ANZEx ANZEx (TestSafe):
Intrinsically-Safe
Ex ia IIC T5 @ +85°C



CE Conformant:
EMC Directive 2014/30/EU – EN 61326



TRX [HPP] or TRY [HPP] in LH2 Housing
FM Global Group (FM Approvals):
Explosion-Proof & Dust/Ignition-Proof
Class I, Division 1, Groups A, B, C & D
Class II & III, Division 1, Groups E, F & G
Environmental Protection: NEMA 4X & IP66
Ambient Temperature Range: -20°C to +60°C



CSA Group (Canadian Standards Association):
Explosion-Proof
Class I, Division 1, Groups A*, B, C, & D
Class II, Groups E, F, & G
Class III, IP66
Ambient Temperature Range: -20°C to +60°C; T6
*For Group A applications, seal all conduits within 18"



ATEX Directive 2014/34/EU (ISseP):
Explosion-Proof/Flameproof
⊕ II G Ex d IIC T6 Gb
⊕ II D Ex tb IIC Db T85°C IP66



ANZEx ANZEx (TestSafe):
Explosion-Proof/Flameproof
Ex d IIC T6 (Tamb 60°C) IP66

TRY & TRX

PC-Programmable Temperature Transmitters

Table 1. TRY & TRX Input and Accuracy Table

Input	Type	α^*	Ohms	Conformance Range	Minimum Span	Input Accuracy**	Maximum Range
RTD	Platinum	0.003750	1000	-50 to 500°C -58 to 932°F	15°C (27°F) for 100 ohm inputs 10°C (18°F) for 200 ohm inputs 7.5°C (13.5°F) for 500 and 1000 ohm inputs	±0.11°C ±0.2°F	-100 to 560°C -148 to 1040°F
		0.003850	100, 200, 300, 400, 500, 1000	-200 to 850°C -328 to 1562°F		±0.21°C ±0.38°F	-240 to 960°C -400 to 1760°F
		0.003902	100, 200, 400 500, 1000	-100 to 650°C -148 to 1202°F		±0.15°C ±0.27°F	-150 to 720°C -238 to 1328°F
		0.003911	100, 500	-200 to 630°C -328 to 1166°F		±0.17°C ±0.31°F	-235 to 710°C -391 to 1310°F
		0.003916	100	-200 to 510°C -328 to 950°F		±0.14°C ±0.25°F	-240 to 580°C -400 to 1076°F
		0.003923	98.129	-200 to 600°C -328 to 1112°F		±0.16°C ±0.29°F	-235 to 680°C -391 to 1256°F
		0.003926	100, 470, 500	-200 to 630°C -328 to 1166°F		±0.17°C ±0.31°F	-235 to 710°C -391 to 1310°F
		0.003928	100	-200 to 850°C -328 to 1562°F		±0.21°C ±0.38°F	-260 to 962°C -436 to 1763.6°F
	Nickel	0.000672	120	-80 to 320°C -112 to 608°F	10°C (18°F)	±0.16°C ±0.29°F	-100 to 360°C -148 to 680°F
		0.000427	9.035	-50 to 250°C -58 to 482°F	100°C (180°F)	±1.2°C ±2.16°F	-65 to 280°C -85 to 536°F
Ohms	Direct resistance or Potentiometer	n/a	n/a	0-4000 ohms	30 ohms	±0.4 ohms	n/a
T/C	J	n/a	n/a	-180 to 770°C -292 to 1418°F	35°C 63°F	±0.28°C ±0.5°F	-210 to 770°C -346 to 1418°F
	K	n/a	n/a	-150 to 1372°C -238 to 2501.6°F	40°C 72°F	±0.3°C ±0.54°F	-270 to 1390°C -454 to 2534°F
	E	n/a	n/a	-170 to 1000°C -274 to 1832°F	35°C 63°F	±0.26°C ±0.47°F	-270 to 1013°C -454 to 1855.4°F
	T	n/a	n/a	-200 to 400°C -328 to 752°F	20°C 36°F	±0.24°C ±0.43°F	-270 to 407°C -454 to 764.6°F
	R	n/a	n/a	0 to 1768°C 32 to 3214.4°F	50°C 90°F	±0.71°C ±1.28°F	-50 to 1786°C -58 to 3246.8°F
	S	n/a	n/a	0 to 1768°C 32 to 3214.4°F	50°C 90°F	±0.71°C ±1.28°F	-50 to 1786°C -58 to 3246.8°F
	B	n/a	n/a	400 to 1820°C 752 to 3308°F	75°C 135°F	±0.43°C ±0.77°F	200 to 1836°C 392 to 3336.8°F
	N	n/a	n/a	-130 to 1300°C -202 to 2372°F	45°C 81°F	±1.33°C ±2.39°F	-270 to 1316°C -454 to 2400.8°F
	C	n/a	n/a	0 to 2315°C 32 to 4199°F	100°C 180°F	±1.16°C ±2.09°F	0 to 2338°C 32 to 4240.4°F
Millivolts	DC	n/a	n/a	-50 to 1000mV	4mV	±0.04mV	-50 to 1000mV

* α values with both 32 and 128-point linearization curves are available. (Lower resolution values provided for compatibility with older units.)

**Accuracy ratings are expressed as a percent of the total conformance range, at spans larger than recommended minimums. (Accuracy ratings for RTD inputs apply at 25°C)

Figure 6. The DIN-style TRY is ideal for Control Room or Cabinet Installations.

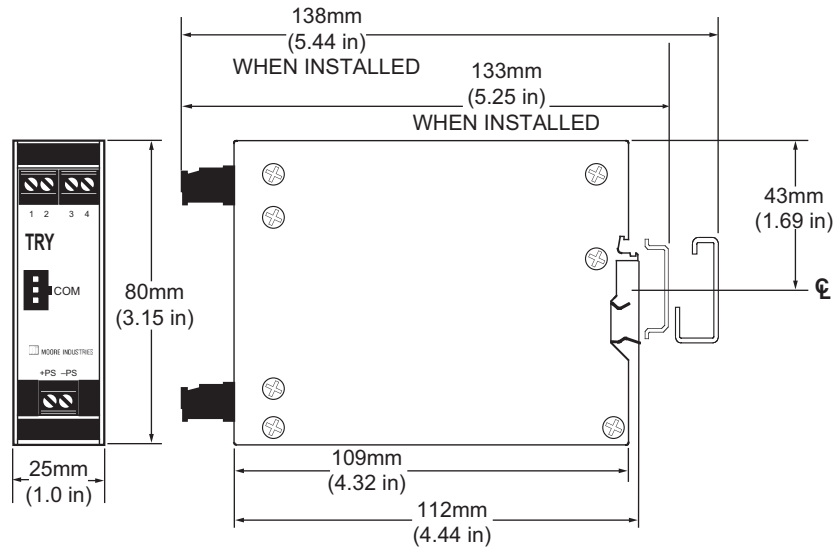

Figure 7. Use the HPP-Style Hockey-Puck Housing for Installation in Field Enclosures.

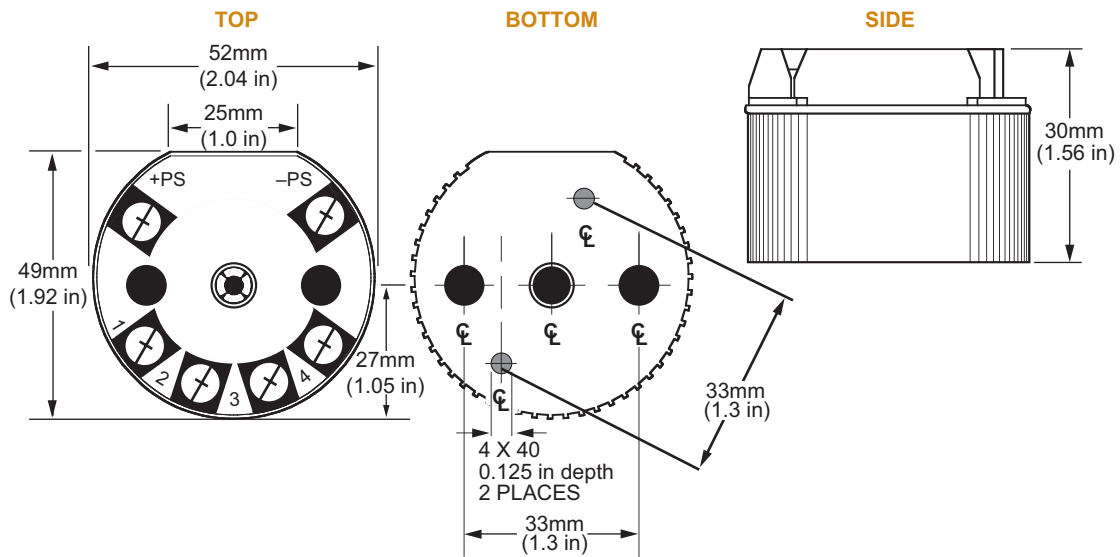
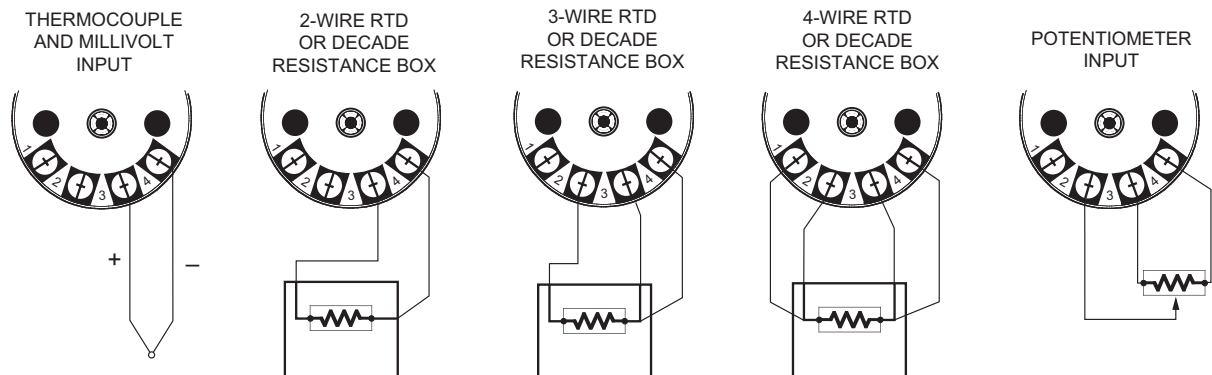

Figure 8. Connecting an Input to the TRY/TRX.



TRY & TRX

PC-Programmable
Temperature Transmitters

Figure 9. The TRY and TRX Feature Rugged, Fully Certified, Ready-to-Install Housing Styles.

