

June 2013

Description

The TFZ Programmable FOUNDATION Fieldbus Temperature Transmitter saves wire and installation costs by allowing up to 32 field devices to be networked onto one, low cost FOUNDATION fieldbus H1 segment.

The loop-powered (2-wire) TFZ offers dozens of input and operation choices. It sets up from the control room over segment wiring using a standard FOUNDATION fieldbus configuration tool to handle 14 RTD types, 9 thermocouple types, as well as direct millivolt and resistance/potentiometer inputs. It converts the input to a FOUNDATION fieldbus H1, two-way digital communication protocol ready for interface with an AMS, DCS or PLC.

Easy-to-Order Temperature Assemblies

One simple model number is all it takes to order our complete temperature assemblies. They include your choice of general location or hazardous area connection head, RTD or T/C sensors, thermowell and process connection.



Available in a variety of mounting styles, the TFZ installs on a pipe or surface in the field, or on a DIN-rail and relay track in a multi-unit enclosure or cabinet.

Features

- **Industry-standard FOUNDATION fieldbus communication.** Featuring a bus connection in accordance with IEC 61158-2 and EN 50170, part 4, the TFZ can be installed in the same segment with all standard FOUNDATION fieldbus devices.
- **Exceptional measurement accuracy.** 20-bit input resolution delivers precise, industry-leading measurements.
- **Easy-to-read, customizable local display.** The large display features alphanumeric characters that can be read easily in the field. It can be customized to display the process variable or the output in user-selectable engineering units.
- **Delivers valuable diagnostic information.** Standard FOUNDATION fieldbus diagnostics provide indication of unwanted process and transmitter conditions.
- **Remote configuration and diagnostics.** The ideal universal plant standard, the TFZ offers versatile input and operation choices, and still can be configured and troubleshooted quickly over the segment, from the control room.
- **Long-term stability.** Provides up to 5 years between scheduled calibrations.
- **Advanced RFI/EMI protection and ambient temperature compensation.** Guard against environmental factors that can quickly degrade measurement accuracy.

Figure 1. Universal, programmable input with FOUNDATION fieldbus digital communication protocol.

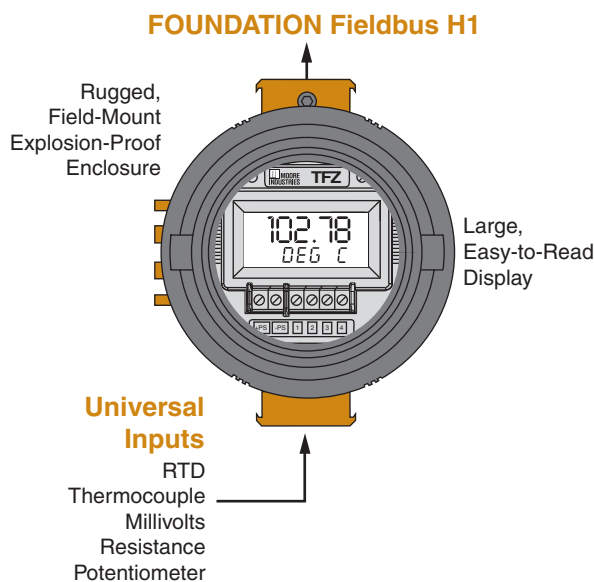

Certifications (see Page 8 for details)



*All product names are trademarks of their respective companies.

TFZ

Programmable FOUNDATION Fieldbus™ Temperature Transmitter

Multidrop Networks Save Wiring Costs

The TFZ is an H1 Basic Device that conforms to the H1 Standard (IEC61158-2, 31.25 kbits/s) and is implemented as a Group 3 (network configurable), Class 31* device.

Acting as a Slave device within a FOUNDATION fieldbus H1 network, up to 32 TFZ transmitters connect in a fieldbus (Figure 2) segment. This means you can save time and money by using a single twisted pair, instead of individual loops, to transmit information from multiple devices.

Function Blocks

Resource Function Block (RB)—Contains diagnostic information, hardware and electronics information (memory, manufacturer identification, device type, software tag) and display configuration parameters.

Temperature Transducer Block (TB)—Contains temperature measurement data, including sensor and terminal temperature. It also includes information about the sensor type, engineering units, linearization, re-ranging, damping, temperature compensation and diagnostics.

Analog Input Block (AI)—Processes measurements from a sensor and makes them available to other function blocks. The output value from the AI block is displayed in engineering units and contains a status indicating the quality of the measurement.

Sets Up from a Hand-Held, DCS or Asset Management System (AMS)

Using its Function Blocks, the TFZ can be remotely programmed in minutes, or interrogated at any time, over the segment using a standard FOUNDATION fieldbus configuration tool. Examples of programmable parameters include:

- **Identification Information**—Product designation/part number, tag, descriptor, installation date, slave address and FOUNDATION fieldbus identification number.
- **Input/Output and Ranges**—Sensor type, span and zero values, lower/upper output ranges and alarm output status.

* Class 31 indicates that the device might publish and/or subscribe data and/or is a client.

Figure 2. The TFZ transmitter's data and configuration can be viewed, tested and changed from the control room using a HART hand-held configurator, DCS or AMS equipped with a standard FOUNDATION fieldbus configuration tool.

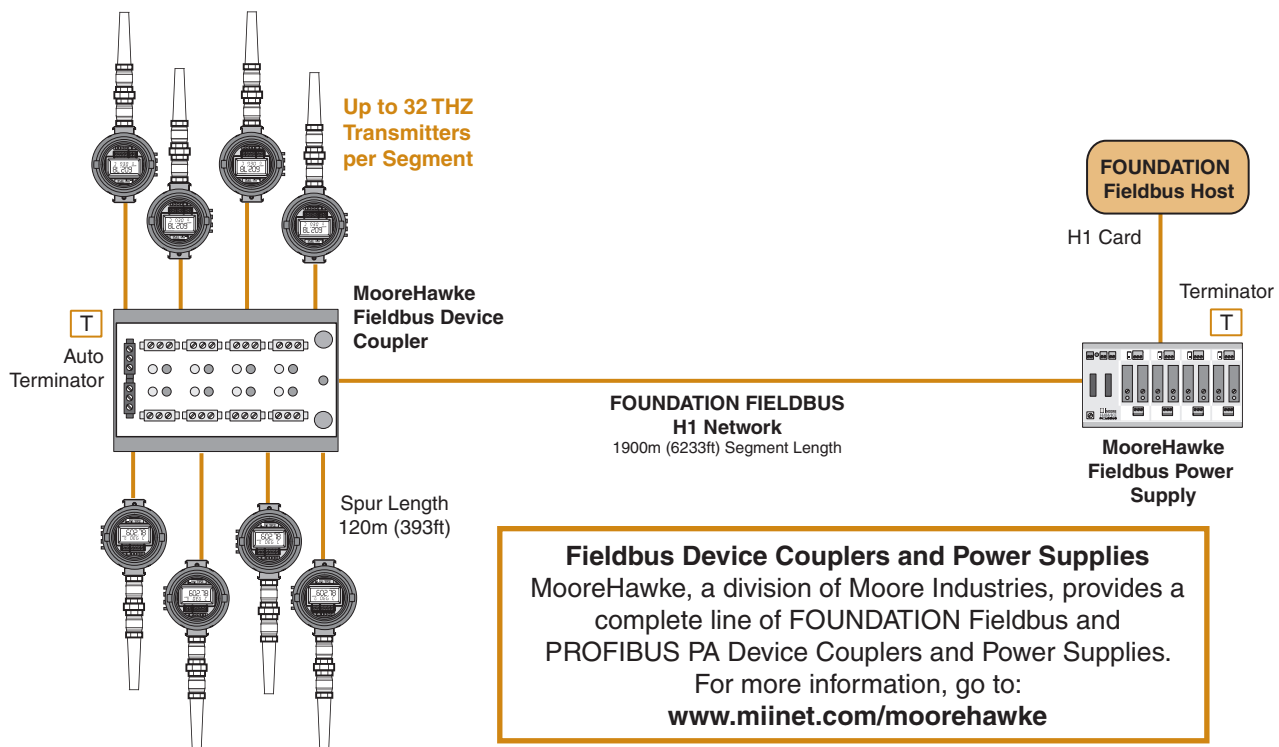

- **Set Damping Time**—Eliminate imprecise readings caused by noise and other insignificant process fluctuations by setting a damping time between 1-30 seconds.
- **View Real-Time Process Values**—View the existing process value (in the appropriate engineering unit), and lower and upper range values as a percentage of output span.

Non-Volatile Memory

If power to the transmitter is lost, the unit resumes normal operation with the parameters you've configured upon reapplication of power.

Total Sensor Diagnostics

TFZ transmitters perform continuous sensor diagnostics. This patented Moore Industries feature can save you from costly lost production time and hours of troubleshooting. If the sensor breaks or otherwise stops sending a signal during operation, the transmitter instantly displays the type and location of the error on its display.

Precise Linearization and RJC

The TFZ uses an advanced linearization method to minimize conformance error. Its Reference (Cold) Junction Compensation techniques produce stable readings even in fluctuating ambient temperature conditions. For non-linear inputs, create custom linearization curves using the fieldbus configuration tool.

Figure 3. The TFZ can be set to measure the segment most critical to the process.

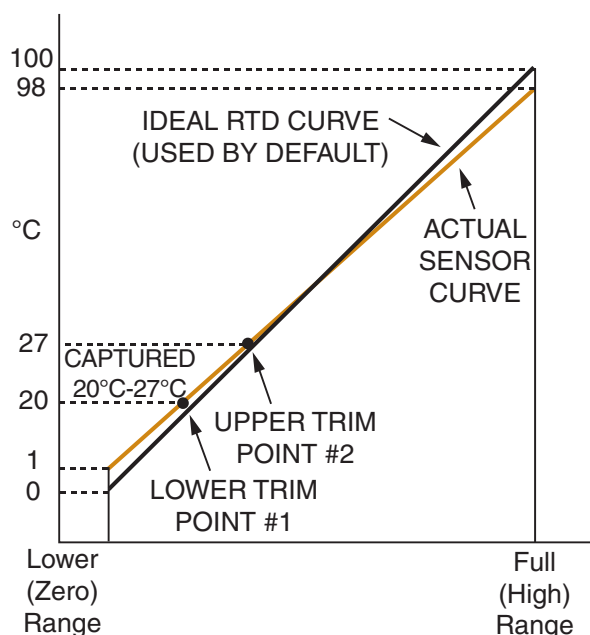

Trims to Respond to Specific Sensor Curve Segments

Most transmitters zero and span values can be calibrated to measure a specific range within a sensor's overall curve capability. However, for even greater measurement accuracy, our transmitter's trim capabilities go much further.

The TFZ can be trimmed with two data points within the selected zero and span measurement range. This advantage allows a complete process range to be monitored, while placing measurement emphasis on a specific segment of the range most critical to the process.

In Figure 3, the actual sensor curve is used in place of the ideal RTD curve between 20°C and 27°C. This provides incredible precision over a limited portion of the span, while measuring the remainder of the span with the TFZ's usual outstanding accuracy.

Specifications

<p>Performance Input Accuracy: Refer to Table 4 Overall Accuracy: The overall accuracy of the unit is the input accuracy. It includes the combined effects of linearity, hysteresis, repeatability and adjustment resolution. It does not include ambient temperature effect. For T/C input, add the RJC error. Reference Junction Compensation: ±0.45°C (±0.81°F) Stability: Refer to Table 1 Isolation: 500Vrms between input, output and case continuous, and will withstand a 500Vac dielectric strength test for one minute (with no breakdown) Step Response Time: 500msec, maximum, 256msec typical from the time an input is applied until the time the corresponding floating point processed variable is available to be read by other FOUNDATION Fieldbus devices Over-voltage Protection: Input, ±5Vdc peak, maximum Digital Input Filter: 50/60Hz (user-selectable)</p>	<p>Performance (Continued) Power Supply Requirement: 9-32Vdc, 10.5mA typical 12.07mA maximum under normal operation; 18mA maximum under fault conditions Supply Range: 9-32V, Foundation Fieldbus Approved Load Effect: N/A T/C Input Impedance: 40Mohms, nominal Excitation Current: RTD and Ohms, 250 microamps, ±10% RTD Lead Wire Resistance Maximum: RTD resistance + 2X lead wire resistance <4000 ohms; Recommended lead wire resistance for three wire connections: <35 ohms/wire; 10 ohm copper sensor <5 ohms Sensor Lead Resistance Effect: 1.0 ohm in reading/ohm of lead resistance for 2-wire sensors; 1.0 ohm in reading/ohm of lead of unbalanced resistance for 3-wire sensors; no effect on 4-wire sensors Resolution: Input, 20-bit</p> <p>Display Type: Top Row, 10mm (0.4 in) high black digits on a reflective background; Bottom Row, 6mm (0.225 in) high digits on a reflective background;</p>	<p>Display (Continued) Two-digit FOUNDATION Fieldbus address indicator Format: Two rows of five alphanumeric characters Decimal Points: Automatically adjusted decimal point with a user selectable maximum up to four places Range: -99999 to 99999 Minimum Display Span: 1.00</p> <p>Ambient Temperature Operating and Storage Range: -40°C to +85°C (-40°F to +185°F) Relative Humidity: 0-95%, non-condensing Ambient Temperature Effect: Refer to Table 2 Effect on Reference Junction Compensation: ±0.005°C of input span/°C change of ambient temperature RFI/EMI Immunity: 20V/m@80-1000MHz, 1kHz AM when tested according to IEC 1000-4-3-1995 with 0.5% of span or less Startup Time: Performance falls within specification 8 seconds after power is applied Noise Rejection: Common mode, 100dB@50/60Hz; Normal Mode: Refer to Table 3</p> <p>Weight 210g (7.4 oz)</p>
---	--	---

Table 1. Long-Term Stability

Stability (% of Max. Span)	Input to FOUNDATION Fieldbus H1		
	1 yr	3 yrs	5 yrs
T/C, mV	0.008	0.014	0.019
RTD, Ohm, Pot	0.047	0.081	0.104

Table 2. Ambient Temperature Effects

Sensor Type	Digital Accuracy per 1°C (1.8°F) Change in Ambient
RTD	0.003°C
T/C	0.003°C + 0.005% of reading
Millivolt	0.005mV + 0.005% of reading
Ohm	0.002 ohms + 0.005% of reading

Table 3. Normal Mode Rejection Ratio

Sensor Type	Max. p-p Voltage Injection for 70dB at 50/60Hz
T/C: J, K, N, C, E	150mV
T/C: T, R, S, B	80mV
Pt RTD: 100, 200, 300 ohms	250mV
Pt RTD: 400, 500, 1000 ohms	1V
Ni: 120 ohms	500mV
Cu: 9.03 ohms	100mV
Resistance	mV
1-4kohms	250-1000
0.25-1kohms	62.5-250
0.125-0.25kohms	31.25-62.5

Table 4. Input and Accuracy

Input	Type	α	Ohms	Conformance Range	Minimum Span	Input Accuracy	Maximum Range	Sensor-to-Transmitter Matching
Platinum	0.003850	100	-200 to 850°C -328 to 1562°F	10°C (18°F)	±0.1°C (±0.18°F)	-240 to 960°C -400 to 1760°F	Up to ±0.014°C (±0.025°F) system accuracy*. *High-accuracy measurements are achieved by using a 4-wire, 1000 ohm platinum RTD with a span of 100°F (50°F minimum) calibrated in our	
		200						
		300						
		400						
		500						
	0.003902	100	-100 to 650°C -148 to 1202°F	100°C	±0.85°C (±1.53°F)	-150 to 720°C -238 to 1328°F		
		200						
		400						
		500						
		1000						
0.003916	100	-200 to 510°C -328 to 950°F			-240 to 580°C -400 to 1076°F			
Nickel	0.00672	120	-80 to 320°C -112 to 608°F			-100 to 360°C -148 to 680°F		
Copper	0.00427	9.035	-50 to 250°C -58 to 482°F	100°C		-65 to 280°C -85 to 536°F		
Ohms	Direct Resistance	n/a	0-4000 ohms	0-4000 ohms	10 ohms	±0.4 ohms	0-4095 ohms	
	Potentiometer		125, 250, 500, 1k, 2k, 4k ohms	0-100%	10%	±0.1%	0-100%	
J	n/a	n/a	-180 to 760°C -292 to 1400°F	35°C 63°F	±0.25°C (±0.45°F)	-210 to 770°C -346 to 1418°F		
	K	n/a	n/a	40°C 72°F	±0.3°C (±0.54°F)	-270 to 1390°C -454 to 2534°F		
							E	n/a
	T	n/a	-170 to 400°C -274 to 752°F	35°C 63°F	±0.25°C (±0.45°F)	-270 to 407°C -454 to 764.6°F		
							R	n/a
	S	n/a	0 to 1760°C 32 to 3200°F	50°C 90°F	±0.55°C (±0.99°F)	-50 to 1786°C -58 to 3246.8°F		
							B	n/a
	N	n/a	-130 to 1300°C -202 to 2372°F	45°C 81°F	±0.4°C (±0.72°F)	-270 to 1316°C -454 to 2400.8°F		
							C	n/a
Millivolts	DC	n/a	n/a	-50 to 1000mV	4mV	15 microvolts		

Ordering Information

Unit	Input	Output	Power	Options	Housing
TFZ Programmable FOUNDATION Fieldbus Transmitter	TPRG Programs to accept RTD, T/C, ohm and mV inputs	H1 FOUNDATION Fieldbus H1	9-32DC for General Location and Non-Incendive Applications 9-30DC for Intrinsically-Safe Applications 9-24DC for FISCO Applications (10.5mA typical; 12.07mA maximum under normal operation; 18mA maximum under fault condition)	-VTD Factory calibration with NIST traceable test report -VTB* Factory calibration using Sensor-to-Transmitter Trimming with NIST traceable test report * The -VTB option applies to units ordered with sensors and complete temperature assemblies only	HP Hockey puck housing and spring clips DN Snap-in mounting for HP case on TS-32 DIN-rail FL Mounting flanges on HP for relay track or screw mounting FLD Mounting flanges on HP for 3½" relay track mounting BH2NG Explosion-Proof enclosure with two 1/2-inch NPT entry ports and a glass cover BH2TG Explosion-Proof enclosure with two 3/4-inch NPT entry ports and a glass cover BH2MG Explosion-Proof enclosure with two M20 x 1.5 NPT entry ports and a glass cover BH3NG Explosion-Proof enclosure with three 1/2-inch NPT entry ports BH3TG Explosion-Proof enclosure with two 3/4-inch side-entry NPT ports, one 1/2" bottom port, and a glass cover BH3MG Explosion-Proof enclosure with two, M20 x 1.5 side-entry ports, one 1/2" bottom-entry port, and a glass cover D2LC 2-Hub, low base, clear cover, IP66/NEMA 4X enclosure SB2NG 2-Hub, Explosion-Proof enclosure with two, ½-inch NPT entry ports and a glass cover SB2MG 2-Hub, Explosion-Proof enclosure with two, M20 x 1.5 entry ports and a glass cover <small> A suffix with BH or SB indicates ANZEx/TestSafe (Ex d) Flame-Proof approvals; 2" pipe-mount kit is included (i.e., BH2MGA or SB2MGA) E suffix with BH or SB indicates ATEX Flame-Proof enclosures; 2" pipe-mount kit is included (i.e., BH2MGE, SB2NGE) P suffix indicates enclosure is equipped with 2" pipe-mount hardware kit (i.e., BH2NGP) </small>

To order, specify: Unit / Input / Output / Power / Options [Housing]
 Model number example: TFZ / TPRG / H1 / 9-32DC [BH2NG]

Figure 4. Sensor/input connections

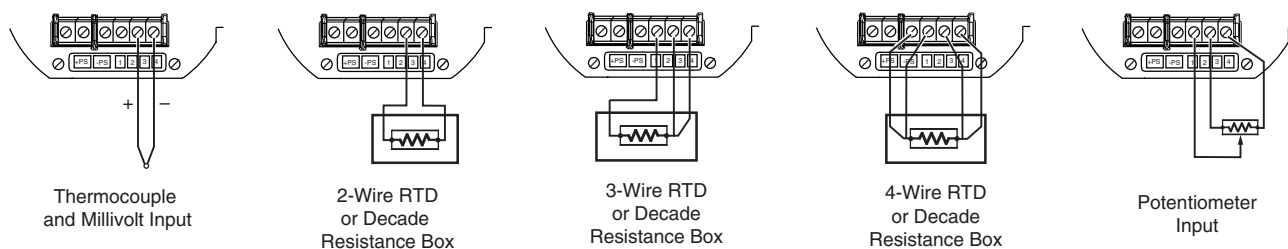

Figure 5. Dimensions for TFZ in HP (hockey-puck) housing with flanges (FL)

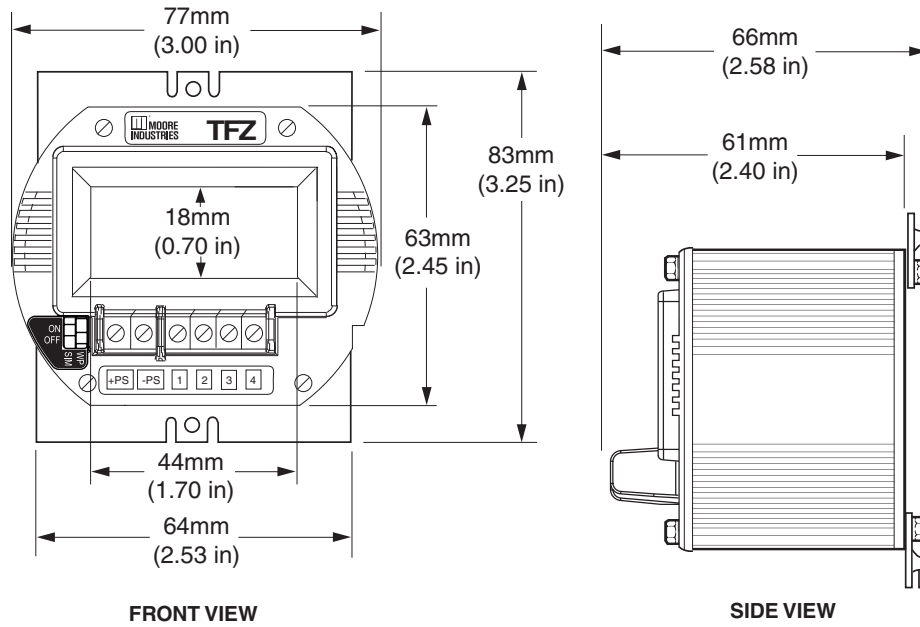
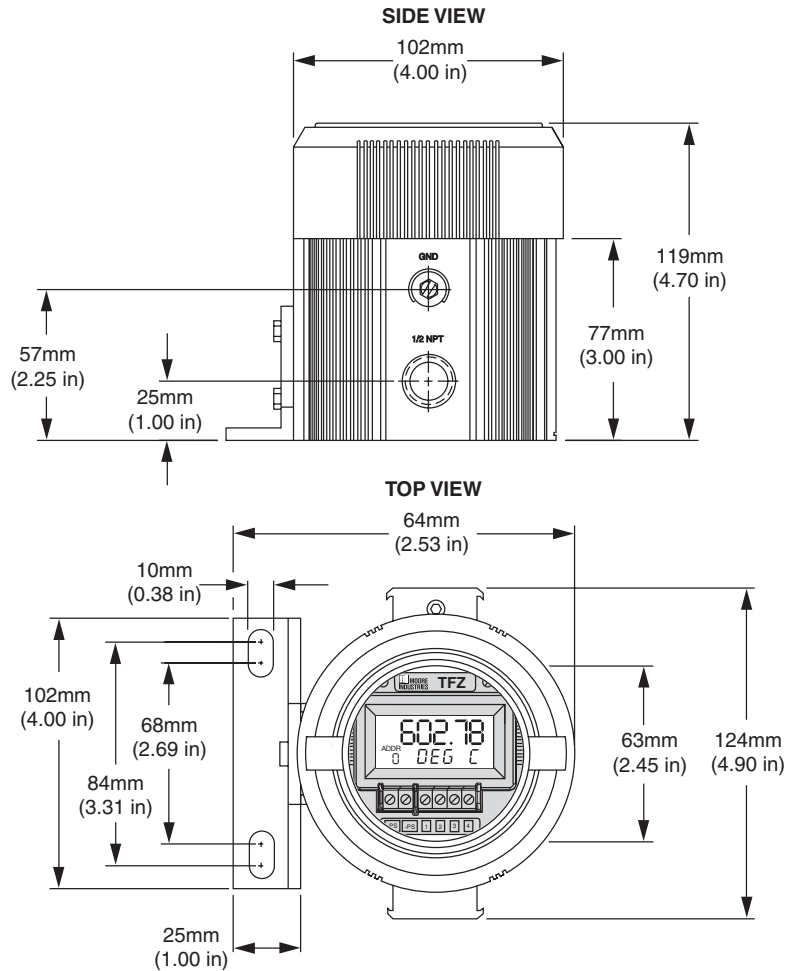

Figure 6. Dimensions for the TFZ in BH field-mount enclosure



TFZ

Programmable FOUNDATION Fieldbus™ Temperature Transmitter

Figure 7. Dimensions for TFZ in D-BOX field-mount enclosure

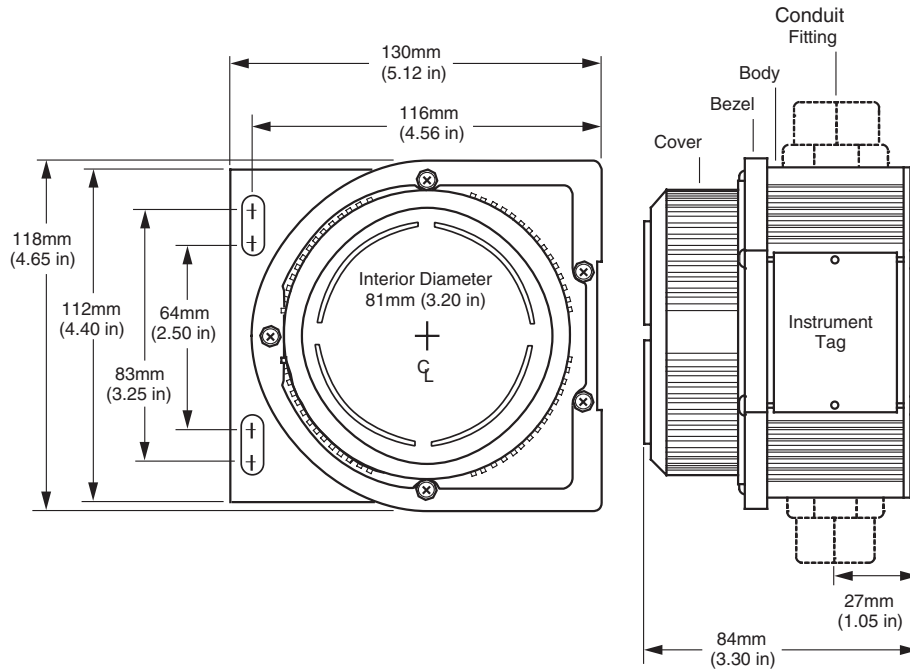

Certifications

TFZ



**Factory Mutual (US/Canada)
Intrinsically-Safe & Non-Incendive**
Class I, Divisions 1 & 2, Groups A, B, C & D
Class I, Zone 0, AEx ia IIC T4



**ATEX Directive 94/9/EC:
Intrinsically-Safe & Type "n"**
II 1G Ex ia IIC, T4@85°C max
II 3G Ex nA IIC, T4@85°C max



**IECEX:
Intrinsically-Safe & Type "n"**
Ex ia IIC T4 Ga
Ex nA nL IIC T4 GA



CE Conformant
EMC Directive 2004/108/EC – EN 61326



**Factory Mutual:
Explosion-Proof & Dust-Ignition Proof**
Class I, Division 1, Groups A*, B, C & D
Class II & III, Division 1, Groups E, F & G
Environmental Protection: Type 4X &IP66
T6 @60°C Maximum Operating Ambient
* For Group A applications, seal all conduits within 18"



**Canadian Standards Association
Explosion-Proof**
Class I, Division 1, Groups A*, B, C & D
Class II & III, Division 1, Groups E, F & G
Environmental Protection: Type 4X &IP66
T6 @60°C Maximum Operating Ambient
* For Group A applications, seal all conduits within 18"



**ATEX Directive 94/9/EC:
Explosion/Flame-Proof**
II 2 G Ex d IIC T6 (Tamb 60°C)
II 2 D Ex tD A21 IP66 T85°C



**ANZEx (TestSafe):
Explosion/Flame-Proof**
Ex d IIC T6 (Tamb 60°C)