

April 2016

## Description

Moore Industries' unique digital/analog hybrid—the TIY Programmable, Isolated Thermocouple Transmitter—combines smart digital technology with advanced analog operation to deliver superior reliability, accuracy and ease of use.

Microprocessor-based, the 2-wire TIY accepts a non-linear temperature input from standard ISA and other thermocouple types, as well as from millivolt sources. It provides an accurate 4-20mA output that is linear with temperature or millivolt input.

**No Hand-Held Configurator Required**—The TIY is fast and simple to configure. Thermocouple type, range, upscale/downscale drive, and the choice of linearization or no linearization can be quickly selected in the field using tactile push buttons and quick-change solderless jumpers.

If linearization is chosen, Moore Industries' linearization method assures high accuracy over wide spans as well as smaller spans.

**No Calibrator Needed**—The TIY features Moore Industries' revolutionary Quick Ranging calibration method. Using the push buttons (instead of potentiometers which can drift) and the integral indicator, precise zero and span adjustments can be made in seconds without a calibrator. The zero or span is displayed on the indicator while the push buttons are used to scroll up or down to the desired value.

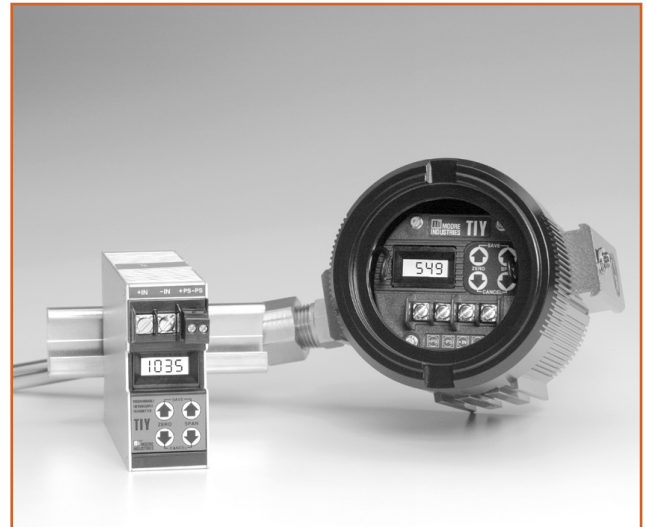

*For field-mounting, the TIY can be ordered in a rugged explosion-proof enclosure. The DIN-style housing is perfect for high-density control room applications.*

## Features

- **Fast and simple to calibrate.** Quick Ranging calibration eliminates the need for hand-held terminals, calibrators, and tools.
- **Integral digital indicator.** Input in °C, °F or mV, as well as span and zero adjustments, can be viewed on the display. During start-up, and even if the output goes over range or under range, the display shows current process temperature.
- **Accepts all common T/C types and ranges.** Input type and temperature range (-190°C to +1820°C) can be quickly field-selected. There is no minimum span.
- **Intelligent self-diagnostics.** Sensor failure, and errors in calibration, memory and unit function are sensed and indicated on the display.
- **Complete isolation.** Prevents false signals due to ground loops.
- **Automatic reference junction compensation.** Long-term accuracy is provided by digital reference junction compensation.

### Certifications



ANZEx



## Specifications

|  |  |  |
|--|--|--|
| <p><b>Performance</b> <b>Output Accuracy:</b> ±0.05% of span (maximum input-to-output error is the sum of the input, output and Reference Junction Compensation accuracy values. See Table 1 and Figure 1 for details.)<br/><b>Ripple:</b> Less than 10mVp-p maximum (up to frequencies of 120Hz) measured across a 250 ohm load resistor<br/><b>Burnout Protection:</b> Upscale drive is the standard factory configuration; downscale drive can be configured via a solderless jumper<br/><b>Operating Limits:</b> No damage up to ±42V on input and ±60V on output<br/><b>Output Protection:</b> Transient protection and reverse polarity protection<br/><b>Output Current Limiting:</b> 125% of span, typical; 130% of span, maximum<br/><b>Load Capability:</b><br/><math display="block">\text{Ohms} = \frac{(V_p - 12V)}{0.024}</math></p> | <p><b>Performance (continued)</b> <b>Common Mode Rejection:</b> At least 120dB at 50Hz/60Hz<br/><b>Isolation:</b> 500Vrms galvanic isolation between input and output terminals<br/><b>RFI/EMI Protection:</b> When tested according to SAMA Standard PMC 33.1, protection rates:<br/><b>DIN and HP/FL Housings:</b> 10V/m – A B C ≤0.1% of maximum span<br/><b>2LG and 2LS (HP housing in explosion-proof enclosure):</b> 30V/m – A B C 0.025% of maximum span<br/><math display="block">\leq</math><br/><b>Ambient Temperature Operation:</b> -40°C to +82°C (-40°F to +180°F)<br/>Momentary, recoverable dimming of display may occur at low temperatures<br/><b>Effect (except reference junction compensation):</b> ±0.01% of maximum span/°C<br/><b>Reference Junction Compensation Effect:</b> ±0.75°C/50°C change in ambient temperature</p> | <p><b>Adjustments</b> <b>Zero and Span:</b> Adjusted via tactile push buttons on front of unit<br/><b>Range:</b> Span changes within an input range (see Range Codes in Table 1) are made with push buttons; changing Range Code selection is done by changing the positions of solderless jumpers</p> <p><b>Indicators</b> <b>Type:</b> 4-digit LCD indicates input value in °C, °F or millivolts (jumper-selectable); also indicates zero and full scale values, problem codes, and high or low table limit warnings<br/><b>Display Accuracy:</b> ±0.1% of maximum span for range code, ±1 count</p> <p><b>Weight</b> <b>DIN Housing:</b> 141 grams (5 ounces)<br/><b>HP Housing:</b> 184 grams (6.5 ounces)</p> |
|--|--|--|

### Certifications



**TIY-HP**  
**CSA Group (Canadian Standards Associations):**  
**Intrinsically-Safe**  
Class I, Division 1, Groups A, B, C, D, T4



**FM Global Group (FM Approvals):**  
**Non-Incendive**  
Class I, Division 2, Groups A, B, C, D



**CE Conformant** – EMC Directive 2014/30/EU:  
EN61326



**TIY-DIN**  
**FM Global Group (FM Approvals):**  
**Non-Incendive**  
Class I, Division 2, Groups A, B, C, D



**CE Conformant** – EMC Directive 2014/30/EU:  
EN61326



**TIY-HP in BH or SB2 Housing**  
**CSA Group (Canadian Standards Association):**  
**Explosion-Proof**

Class I, Division 1, Groups A\*, B, C & D  
Class II, III, Groups E, F & G  
Type 4X, IP66

Ambient Temp. Range: -20°C to +85°C; T4

*\*For U.S. Group A applications, seal all conduits within 18"*

*\*For U.S. Group A applications, seal all conduits within 18"*



**\*Factory Mutual Approvals (FM Global Group):**

**Explosion-Proof & Dust-Ignition Proof**  
Class I, Division 1, Groups A\*, B, C & D  
Class II & III, Division 1, Groups E, F & G  
**Environmental Protection: Type 4X & IP66**  
T6 @ 60°C Maximum Operating Ambient

*\*For Group A applications, seal all conduits within 18"*

**ANZEx Test Safe – ANZEx (Australia)**

**Flameproof**  
Ex d IIC T6 (Tamb 60°C)  
ANZEx 07.3027



**ISseP – ATEX**  
**Flameproof**

Ex II 2 G Ex d IIC T6 Gb  
Ex II 2 D Ex tb IIIC Db T85°C IP66

## Ordering Information

| Unit | Input   | Output                                       | Power   | Options   | Housing   |
|------|---|--|---|---|---|
| TIY  | See Range Codes (e.g., J1, K2, N1) in Table 1 | 4-20MA into 600 ohms with 24Vdc power supply | 12-30DC (required for -ISC option)<br>12-42DC | <p><b>-DD</b> Downscale Drive—output goes downscale within two seconds after an open input or an instrument fault is detected (Upscale or Downscale Drive is jumper-selectable)</p> <p><b>-DDX**</b> Direct Downscale Drive—output goes downscale on open input. Output will not exceed process value on open input or reconnection of an open input</p> <p><b>-NL</b> Configured to provide output linear with input, rather than linear with temperature (jumper-selectable)</p> <p><b>-SP1</b> Low temperature range for J- and T-type thermocouples (replaces N1 and N2 Range Codes)</p> <p><b>-SP2</b> Required for B1 Range Code (replaces S1 Range Code)</p> <p><b>-CE</b> EMC conformant</p> <p><b>-ISC</b> Intrinsically-Safe, CSA (12-30Vdc power required)</p>                           | <p><b>BH2NG</b> (*) or (‡) Aluminum Explosion-Proof enclosure with two ½-inch NPT entry ports and a glass cover</p> <p><b>BH2TG</b> (*) or (‡) Aluminum Explosion-Proof enclosure with two ¼-inch NPT entry ports and a glass cover</p> <p><b>BH2MG</b> (*) or (‡) Aluminum Explosion-Proof enclosure with two M20 x 1.5 NPT entry ports and a glass cover</p> <p><b>BH3NG</b> (*) or (‡) Aluminum Explosion-Proof enclosure with three ½-inch NPT entry ports and a glass cover</p> <p><b>BH3TG</b> (*) or (‡) Aluminum Explosion-Proof enclosure with two ¼-inch NPT side-entry ports, one ½-inch NPT bottom-entry port and a glass cover</p> <p><b>BH3MG</b> (*) or (‡) Aluminum Explosion-Proof enclosure with two M20 x 1.5 metric side-entry ports, one ½-inch NPT bottom-entry port, and a glass cover</p> <p><b>D2LC</b> 2-Hub, low base, clear cover, NEMA 4X (IP 66) enclosure</p> <p><b>D2LS</b> 2-Hub, low base, solid black cover, NEMA 4X (IP 66) enclosure</p> <p><b>HP</b> Hockey-puck housing (only) includes spring clips for mounting in the above enclosures</p> <p><b>FL</b> Hockey-puck housing with flanges for surface or relay track mounting</p> <p>* Either <b>A</b> or <b>E</b> suffix (comes supplied with 2" pipe mount hardware)</p> <p><b>A</b> suffix indicates ANZEx/TestSafe (Ex d) Flameproof approvals (i.e. BH2MGA)</p> <p><b>E</b> suffix indicates ATEX (Ex d and ID) Flameproof approvals (i.e. BH2MGE)</p> <p>‡ <b>P</b> suffix indicates enclosure comes equipped with base plate and U-bolts for mounting on a 2-inch pipe (i.e. BH2NGP)</p> <p>See BH and D-BOX Datasheets for additional information.</p> |
| TIY  | See Range Codes (e.g., J1, K2, N1) in Table 1 | 4-20MA into 600 ohms with 24Vdc power supply | 12-42DC                                       | <p><b>-DD</b> Downscale Drive—output goes downscale within two seconds after an open input or an instrument fault is detected (Upscale or Downscale Drive is jumper-selectable)</p> <p><b>-DDX**</b> Direct Downscale Drive—output goes downscale on open input. Output will not exceed process value on open input or reconnection of an open input</p> <p><b>-NL</b> Configured to provide output linear with input, rather than linear with temperature (jumper-selectable)</p> <p><b>-SP1</b> Low temperature range for J- and T-type thermocouples (replaces N1 and N2 Range Codes)</p> <p><b>-SP2</b> Required for B1 Range Code (replaces S1 Range Code)</p> <p>*Consult factory for availability.<br/>**The DDX option prohibits the TIY from being configured for an upscale failsafe.</p> | <b>DIN</b> DIN housing mounts on "G" or Top Hat Rail  |

**When ordering, specify:** Unit / Input code, temperature or millivolt range and scale (°C, °F or mV) / Output / Power / Options [Housing]  
**Model number examples:** TIY / K1-0-100C / 4-20MA / 12-42DC [DIN]  
 TIY / MV1-0-75MV / 4-20MA / 12-42DC [BH2NG]

**Table 1. Range Codes for Thermocouple and Millivolt Input Ranges**

| Input Type                       | Range Code  | Range Limits  |                                   | Input                          | Accuracy            |                   | Reference Junction Compensation |
|----------------------------------|-------------|---|-----------------------------------|--------------------------------|---------------------|-------------------|---------------------------------|
|                                  |             | Lower <sup>1</sup><br>(= to 4mA)  | Upper <sup>2</sup><br>(= to 20mA) |                                | Output <sup>3</sup> |                   |                                 |
| <b>Thermocouple Input Ranges</b> |             |   |                                   |                                |                     |                   |                                 |
| J                                | <b>J1</b>   | -50°C (-58°F)   | 450°C (842°F)                     | ±0.08°C (±0.14°F)              | ±0.05% of span      | ±0.25°C (±0.45°F) |                                 |
|                                  | <b>J2</b>   | -50°C (-58°F)   | 760°C (1400°F)                    | ±0.25°C (±0.45°F)              | ±0.05% of span      | ±0.25°C (±0.45°F) |                                 |
|                                  | <b>J3*</b>  | -130°C (-202°F)   | 130°C (266°F)                     | ±0.6°C (±0.10°F)               | ±0.05% of span      | ±0.25°C (±0.45°F) |                                 |
| K                                | <b>K1</b>   | -50°C (-58°F)   | 450°C (842°F)                     | ±0.10°C (±0.18°F)              | ±0.05% of span      | ±0.25°C (±0.45°F) |                                 |
|                                  | <b>K2</b>   | -50°C (-58°F)   | 1370°C (2498°F)                   | ±0.30°C (±0.54°F)              | ±0.05% of span      | ±0.25°C (±0.45°F) |                                 |
| E                                | <b>E1</b>   | -10°C (14°F)  | 350°C (662°F)                     | ±0.10°C (±0.18°F)              | ±0.05% of span      | ±0.25°C (±0.45°F) |                                 |
|                                  | <b>E2</b>   | -100°C (-148°F)   | 1000°C (1832°F)                   | ±0.25°C (±0.45°F)              | ±0.05% of span      | ±0.25°C (±0.45°F) |                                 |
|                                  | <b>E3</b>   | -100°C (-148°F)   | 50°C (122°F)                      | ±0.06°C (±0.10°F)              | ±0.05% of span      | ±0.25°C (±0.45°F) |                                 |
| T                                | <b>T1</b>   | -50°C (-58°F)   | 400°C (752°F)                     | ±0.10°C (±0.18°F)              | ±0.05% of span      | ±0.25°C (±0.45°F) |                                 |
|                                  | <b>T2</b>   | -100°C (-148°F)   | 100°C (212°F)                     | ±0.08°C (±0.14°F)              | ±0.05% of span      | ±0.25°C (±0.45°F) |                                 |
|                                  | <b>T3*</b>  | -190°C (-310°F)   | 50°C (122°F)                      | ±0.12°C (±0.21°F)              | ±0.05% of span      | ±0.25°C (±0.45°F) |                                 |
| R                                | <b>R1</b>   | -18°C (0°F)   | 1760°C (3200°F)                   | ±0.60°C (±1.08°F)              | ±0.05% of span      | ±0.25°C (±0.45°F) |                                 |
| S                                | <b>S1</b>   | -18°C (0°F)   | 1760°C (3200°F)                   | ±0.50°C (±0.90°F)              | ±0.05% of span      | ±0.25°C (±0.45°F) |                                 |
| N                                | <b>N1</b>   | -50°C (-58°F)   | 1300°C (2372°F)                   | ±0.40°C (±0.72°F)              | ±0.05% of span      | ±0.25°C (±0.45°F) |                                 |
|                                  | <b>N2</b>   | -50°C (-58°F)   | 700°C (1292°F)                    | ±0.15°C (±0.27°F)              | ±0.05% of span      | ±0.25°C (±0.45°F) |                                 |
| B                                | <b>B1**</b> | 200°C (392°F)   | 1820°C (3308°F)                   | ±0.80°C (±1.44°F) <sup>4</sup> | ±0.05% of span      | ±0.25°C (±0.45°F) |                                 |
| <b>Millivolt Input Ranges</b>    |             |   |                                   |                                |                     |                   |                                 |
| mV                               | <b>MV1</b>  | -10mV   | 75mV                              | 10 microvolts                  | ±0.05% of span      | N/A               |                                 |
|                                  | <b>MV2</b>  | -6mV  | 24mV                              | 3.4 microvolts                 | ±0.05% of span      | N/A               |                                 |
|                                  | <b>MV3</b>  | -10mV   | 7mV                               | 2 microvolts                   | ±0.05% of span      | N/A               |                                 |
| No Code                          | <b>PRG</b>  | Specify when input type and range are undetermined or when unit will be stocked as a universal spare (PRG default is J1-0-100°C). |                                   |                                |                     |                   |                                 |

\*SP1 option required for J3 and T3 Range Codes (replaces N1 and N2 Range Codes).

\*\* SP2 option required for B1 Range Code (replaces S1 Range Code).

### NOTES

1. The TIY output will limit at values which are 5% of maximum span lower than this value and will then display “-LO-”.
2. The TIY output will not exceed values which are 10% of maximum span greater than this value. When exceeded, the display reads “-HI-”.
3. Output accuracy is in relation to the unit's calibrated span (±0.05% of actual span that will be used for the application).
4. Valid for 400°C and above.

**Figure 1.** Determining Maximum Error (see Table 1 for Input, Output and Reference Junction Compensation Accuracies)

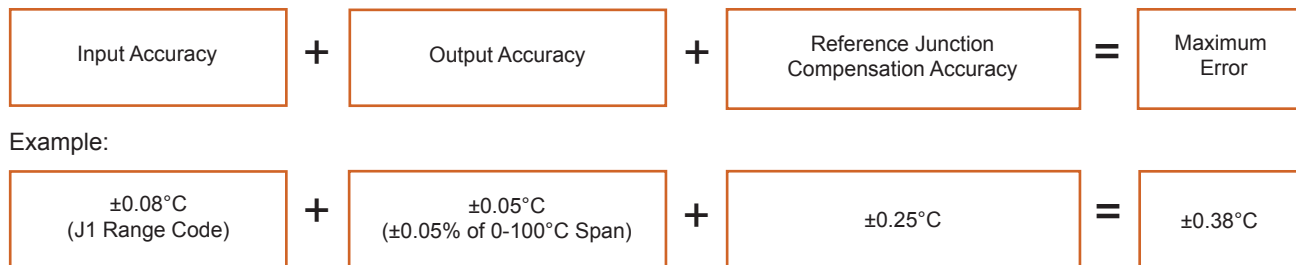

**Figure 2.** Outline Dimensions for DIN-Style Housing

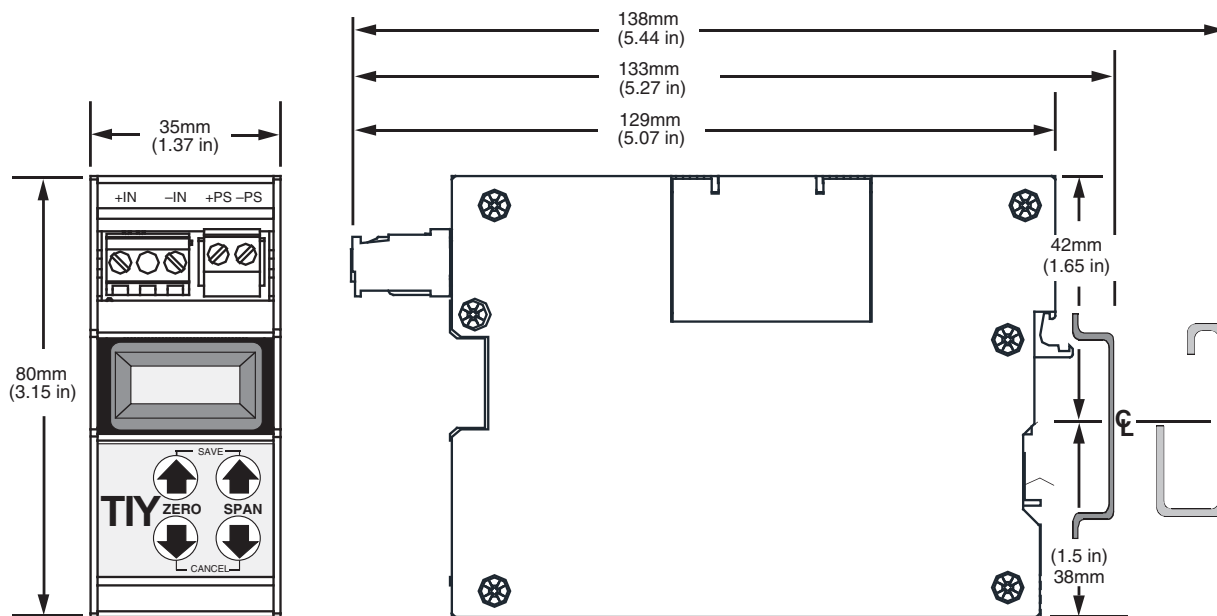

**Figure 3.** Outline Dimensions for FL and HP Housings

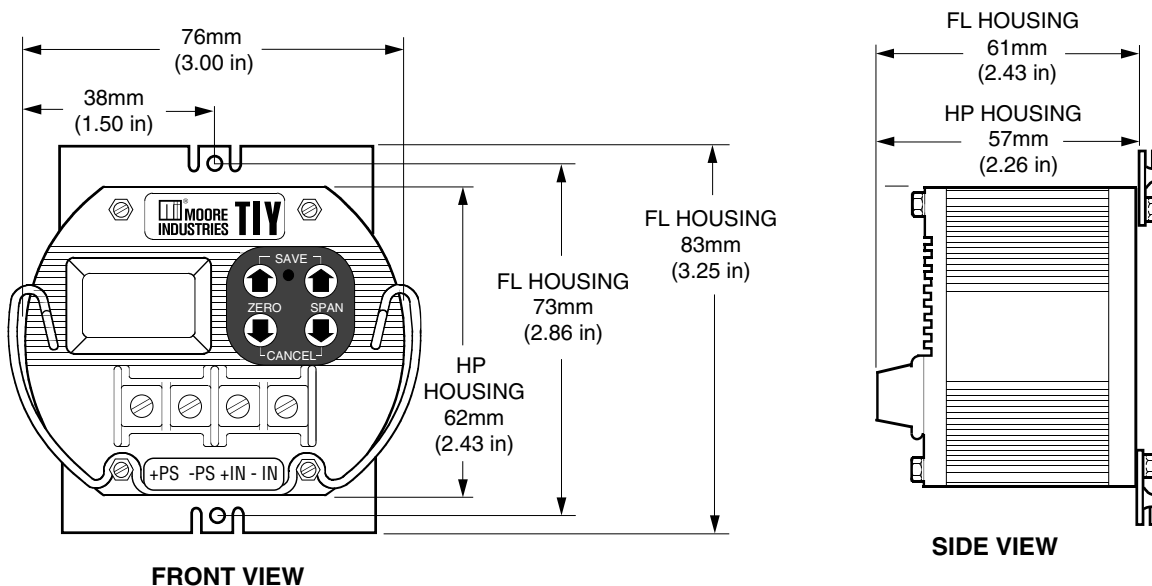

# TIY

Programmable, Isolated  
Thermocouple Transmitter

Figure 4. Dimensions of the TIY in a BH Housing

