

May 2019

Sets Up in a Minute. Stable for Years.

The very affordable TEMPTATION 2000 RTD Temperature Transmitter (Model T2X) delivers long-term stability in an array of basic temperature sensing applications. PC-programmable in a minute or less, the T2X accepts a wide range of RTD inputs. It provides a linear, non-isolated 4-20mA output ready for direct interface with a monitoring/control system.

Dimensions

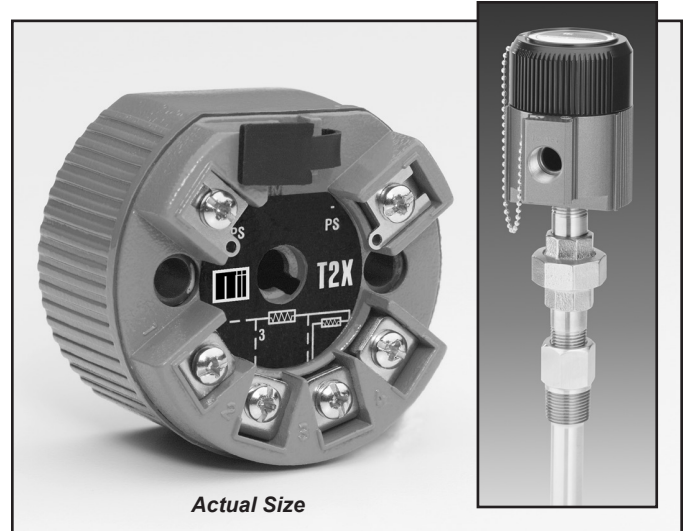
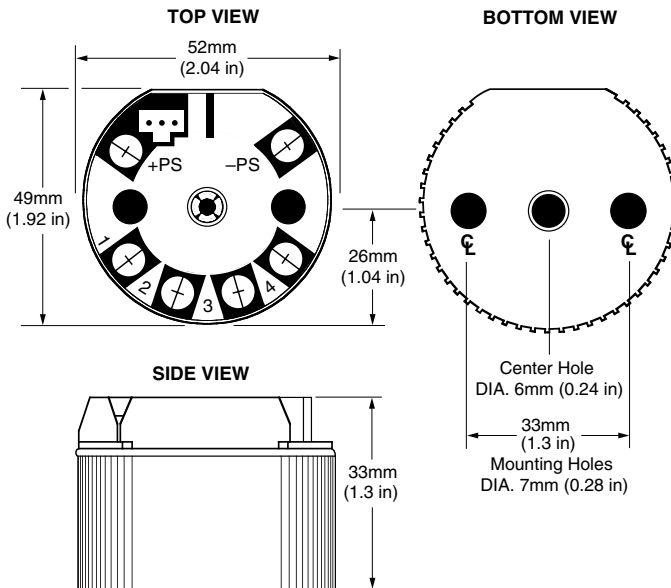

The TEMPTATION 2000 is offered in a standard head-mount housing, in field-ready connection heads, and with a DIN-rail mounting option. Complete sensor and thermowell assemblies are also available.

Features

- Handles 2-, 3- and 4-Wire RTD (Pt100, Pt1000, Ni120, and Cu10) and 0-2200 ohm inputs.
- 4-20mA output is linear with temperature.
- Sets up in a minute or less with single window Intelligent PC Configuration Software.
- High accuracy of up to $\pm 0.21^{\circ}\text{C}$ ($\pm 0.38^{\circ}\text{F}$).
- Long-term stability of up to 5 years.
- 2-Wire (loop-powered).
- *Total Sensor Diagnostics* show which RTD wire has failed, and drives the output upscale or downscale.
- Selectable output damping (0-5 seconds).
- RFI/EMI resistant.
- NEMA 4X, IP66 connection heads for rugged field environments. DIN-rail mounting is also available.
- Full 3-year warranty.

Hookup Diagrams

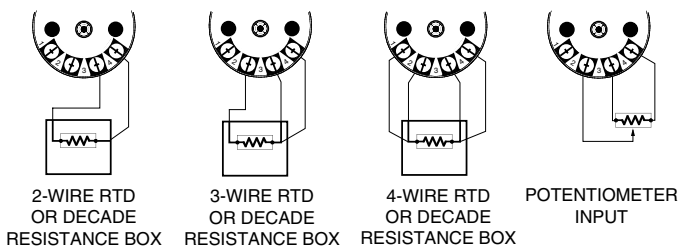

Certifications



ANZEX



TEMPTATION 2000

T2X RTD Temperature Transmitter

Specifications

Performance **Input Accuracy:**
Platinum RTD,
±0.2°C (±0.36°F)
Nickel RTD,
±0.16°C (±0.29°F)
Copper RTD,
±1.2°C (±2.16°F)
Ohms, ±0.4Ω
Output Accuracy:
±0.05% of span
NOTE: Overall accuracy is determined by combining input and output accuracy. It includes the combined effects of linearity, hysteresis, repeatability, and adjustment resolution. It does not include ambient temperature effect.
Stability (max. span):
1 year = ±0.12%
3 years = ±0.21%
5 years = ±0.27%
Measurement Cycle:
Output updates at least 8 times per second
Output Response Time:
256msec typical, 300msec maximum, for the output to change from 10% to 90% for an input step change of 0% to 100%
Ripple: 10mV peak-to-peak measured across a 250ohm load resistor at frequencies up to 120Hz

Performance (continued) **Over-Voltage Protection:**
Input, 4Vdc peak, max.;
Output, 48Vdc, max.
Digital Input Filter:
User-selectable, 50/60Hz
Power Supply and Load Effects: Negligible within specified power limits
Load Capability:
670 ohms @ 24V

$$\Omega = \frac{\text{Supply Voltage} - 8V}{0.024A}$$

Burnout Protection:
User-programmable,
Upscale to 24mA;
Downscale to 3.3mA
Output Current Limiting:
25mA maximum
RTD & Ohms Excitation:
250µA, ±10%
RTD Lead Wire Resistance Maximum:
RTD resistance + 2 times the lead wire resistance must be less than 2000 ohms; Recommended <35 ohms per wire for three wire inputs; <5 ohms per wire for 10 ohm Cu inputs
Damping: 0-5 seconds (user selectable)

Ambient Temperature **Operating & Storage Range:**
-40°C to +85°C
(-40°F to +185°F)
Relative Humidity:
0-95%, non-condensing
Ambient Temperature Effect:
±0.03% of span/°C
RFI/EMI Immunity:
20V/M@20-1000MHz, when tested according to SAMA standard 33.1.
(10V/m@80-1000MHz, 1kHz AM, when tested according to IEC 1000-4-3-1995)
Noise Rejection:
Common mode:
100dB @ 50/60Hz;
Normal Mode: 70dB typical at 200mV peak-to-peak @ 50/60Hz

Set Up All settings are made using Moore Industries' Intelligent PC Configuration Software, and then stored in non-volatile memory

Weight **HPP:** 101 g (3.6 oz)
HPP in LH1: 428 g (15.1 oz)
HPP in LH2: 428 g (15.1 oz)
HPP in CH6: 173 g (6.1 oz)

Accessories

Each T2X order comes with one copy of our Intelligent PC Configuration Software (Windows® compatible). To order additional software or cables:

Part Number	Part
750-75E05-01	Intelligent PC Configuration Software
803-039-26	Isolated Serial Configuration Cable (9-pin Serial Port)
803-040-26	Non-Isolated Serial Configuration Cable (9-pin Serial Port)
804-030-26	Fuse Protected, Non-Isolated USB Communication Cable (required by ATEX for products installed in Intrinsically-Safe areas)

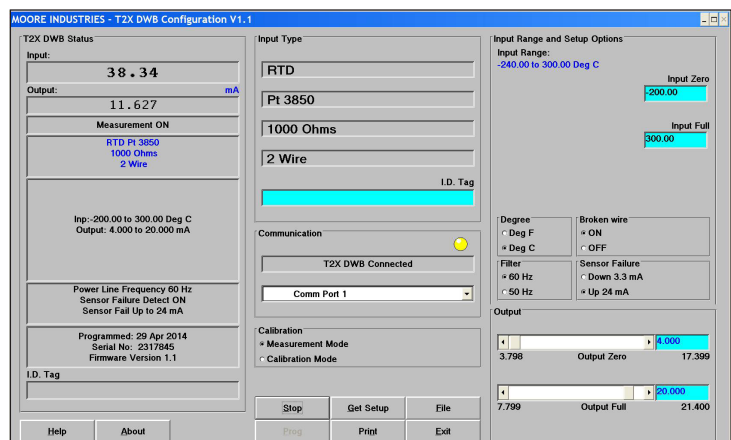

Don't See What You Need?

We offer a wide range of temperature assembly choices - this data sheet provides just a few examples. Whatever your temperature assembly needs are, our temperature interface solution experts are ready to help!

TEMPTATION 2000

T2X RTD Temperature Transmitter

Select one from each category to order: **Temperature Transmitter and Enclosure**

Unit	Input	Output	Power	Options	Housing
T2X TEMPTATION 2000, Non-Isolated PC-Programmable 2-Wire RTD Transmitter	PRG User selectable with PC Configuration Software	4-20MA User scaleable with PC Configuration Software	8-30DC for Intrinsically-Safe 8-42DC	-ISC (Intrinsically-Safe, CSA) -ISE (Intrinsically-Safe, ATEX/LCIE) -ISF (Intrinsically-Safe, FM Approvals)	HPP Hockey-puck housing for mounting in standard connection heads LH1NS‡ Connection head (FM approved, NEMA 4X, IP66) with two entry ports: ½-inch NPT cable and process-black PBT polyester cover LH1MS‡ Connection head (FM approved, NEMA 4X, IP66) with two entry ports: M20 cable and ½-inch NPT process-black PBT polyester cover NEMA 4X, IP66 connection head with one M20 entry port and one G½ (BSP) entry port (aluminum body with VALOX 357U cover) LH1CS‡ Connection head with two entry ports: M20 cable and G½ (BSP) process-black PBT polyester cover LH1NX Connection head with ½-inch NPT entry and mounting plate for customer's air duct opening-black PBT polyester cover LH2NS* Explosion-proof connection head with two entry ports: ½-inch NPT cable and process-black metal cover LH2MS* Explosion-proof connection head with two entry ports: M20 cable and ½-inch NPT process-black metal cover NOTE: *A suffix with LH2 indicates ANZEx/TestSafe (Ex d) Flameproof approval; 2" pipe-mount kit included (i.e., LH2MSA) *E suffix with LH2 denotes ATEX Flameproof enclosure; 2" pipe-mount kit included (i.e., LH2MSE) ‡P suffix indicates enclosure is equipped with 2" pipe-mount hardware kit (i.e., LH1NSP)

Model Number Example: T2X / PRG / 4-20MA / 8-42DC [HPP]

Certifications

 **T2X-HPP**
FM Global Group (FM Approvals):
Intrinsically-Safe
 Class I, II & III Division 1, Groups A thru G
 Class I, Zone 0, AEx ia IIC T6 Ta = +60°C
Non-Incendive
 Class I, Division 2, Groups A, B, C & D
Temperature Class T6 @ 60°C Ambient

 **CSA Group (Canadian Standards Association):**
General/Ordinary Location
Intrinsically-Safe
 Class I, Division 1, Groups A, B, C & D
Non-Incendive
 Class I, Division 2, Groups A, B, C & D
Temperature Code T6 @ 60°C Ambient

 **ATEX Directive 2014/34/EU (LCIE):**
Intrinsically-Safe
 II 2G EEx ib IIB T6 Ta = +60°C

 **CE Conformant:**
 EMC Directive 2014/30/EU – EN 61326

 **T2X in LH2 Housing**
FM Global Group (FM Approvals):
Explosion-Proof & Dust-Ignition Proof
 Class I, Division 1, Groups A, B, C & D
 Class II & III, Division 1, Groups E, F & G
Environmental Protection: NEMA 4X & IP66
 Ambient Temperature Range: -20°C to +60°C

 **CSA Group (Canadian Standards Association):**
Explosion-Proof
 Class I, Division 1, Groups A*, B, C & D
 Class II, Groups E, F & G
 Class III, IP66
 Ambient Temperature Range: -20°C to +60°C; T6
**For Group A applications, seal all conduits within 18"*

 **ATEX Directive 2014/34/EU (ISseP):**
 II 2 G Ex d IIC T6 (Tamb 60°C)
 II 2 D Ex tD A21 IP66 T85°C

ANZEx
ANZEx (TestSafe):
Explosion/Flameproof
 Ex d IIC T6 (Tamb 60°C) IP66

Input Types and Ranges

Input	Type	Ω	Ω	Conformance Range	Maximum Range*	Minimum Span
RTD 2-Wire 3-Wire 4-Wire	Platinum	0.003850	100, 200, 300, 400, 500	-200 to 850°C (-328 to 1562°F)	-240 to 960°C (-400 to 1760°F)	10°C (18°F)
			1000	-200 to 300°C (-328 to 572°F)	-240 to 300°C (-400 to 572°F)	
		0.003902	100, 200, 400, 500	-100 to 650°C (-148 to 1202°F)	-150 to 720°C (-238 to 1328°F)	
			1000	-100 to 300°C (-148 to 572°F)	-150 to 300°C (-238 to 572°F)	
	0.003916	100	-200 to 510°C (-328 to 950°F)	-240 to 580°C (-400 to 1076°F)		
Nickel	0.00672	120	-80 to 320°C (-112 to 608°F)	-100 to 360°C (-148 to 680°F)	10°C (18°F)	
Copper	0.00427	9.035	-50 to 250°C (-58 to 482°F)	-203.19 to 300.53°C (-333.74 to 572.95°F)	100°C(180°F)	
Ω	Resistance Potentiometer	N/A	0-2200 Ω	0-2200 Ω	0-2200 Ω	30 Ω

* Transmitter will measure ranges outside of the Conformance Range with some degradation to accuracy ratings. Consult the factory for details.

TEMPTATION 2000

T2X RTD Temperature Transmitter

Figure 1. The T2X Offers Rugged, Fully Certified, Ready-to-Install Housing Styles.

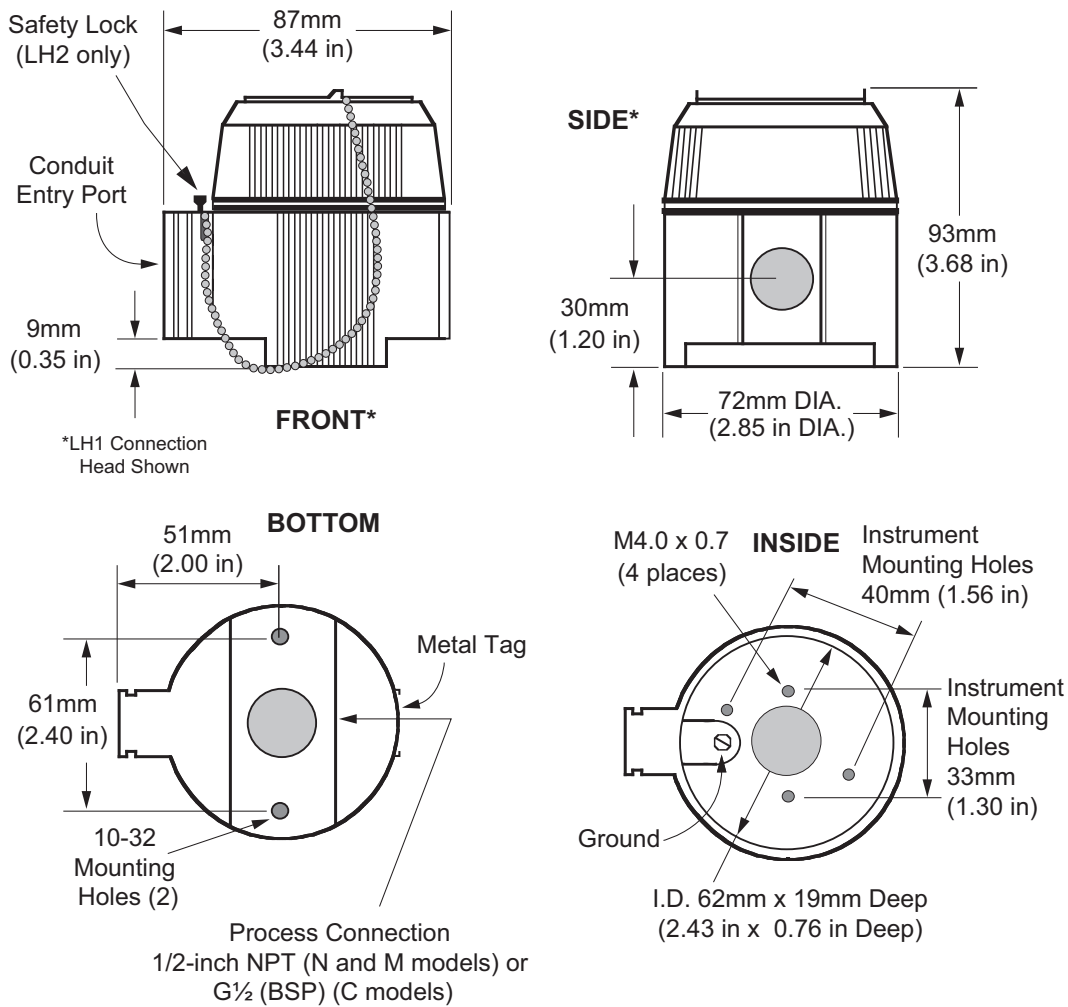

2-INCH PIPE MOUNTING HARDWARE

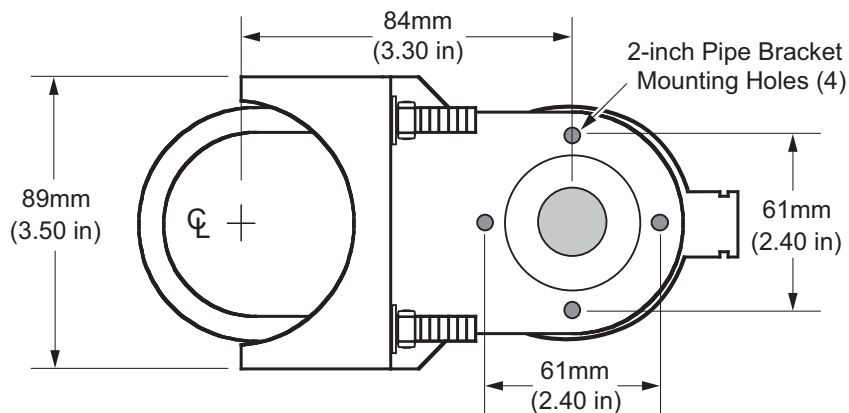

United States • info@miinet.com
 Tel: (818) 894-7111 • FAX: (818) 891-2816
 Australia • sales@mooreind.com.au
 Tel: (02) 8536-7200 • FAX: (02) 9525-7296

Belgium • info@mooreind.be
 Tel: 03/448.10.18 • FAX: 03/440.17.97
 The Netherlands • sales@mooreind.nl
 Tel: (0)344-617971 • FAX: (0)344-615920

China • sales@mooreind.sh.cn
 Tel: 86-21-62491499 • FAX: 86-21-62490635
 United Kingdom • sales@mooreind.com
 Tel: 01293 514488 • FAX: 01293 536852