

## Features

- 2-way normally open operation
- Unique double disc design with overtravel provides redundant sealing for leak tight shutoff in the closed (energized) position
- Visual indication of open & shut position (suffix C)
- Proof of Closure Switch 1 amp (suffix C)
- Valves provided with 1/8" NPT downstream pipe tap with plug for routine testing

## Fluid

Fuel Gas

## Construction

Valve Parts in Contact with Fluids	
Body	Aluminum
Seals and Disc	NBR
Core Tube	305 Stainless Steel
Core Guide	Acetal (20, 20.1 watt only)
Rider Ring	PTFE (20, 20.1 watt only)
Core and Plugnut	430F Stainless Steel
Springs	302 Stainless Steel
Shading Coil	Copper
Pipe Plug	Zinc-Plated Steel

## Electrical

Solenoid Enclosure	Standard Coil and Class of Insulation	Watt Rating and Power Consumption			Ambient Temp. °F	Spare Coil Family	
		AC				General Purpose	Explosionproof
		Watts	VA Holding	VA Inrush		AC	AC
General Purpose	F	20	43	240	-40 to 125	99257	-
	H	20	43	240	-40 to 140	222345	-
	F	28.2	50	385	-40 to 125	206409	-
	H	28.2	50	385	-40 to 140	-	-
Watertight	F	17.1	40	93	-40 to 125	238610	238614
	H	17.1	40	93	-40 to 140	-	-
	F	20.1	43	240	-40 to 125	272610	272614
	H	20.1	43	240	-40 to 140	272810	-

**Standard Voltages**  
**General Purpose:** 24, 120, 240 volts AC, 60 Hz (or 110, 220 volts AC, 50 Hz) (99257); 120, 240 volts AC, 60 Hz (or 110, 220 volts AC, 50 Hz) (206409). (Note: 24 volt AC, 60 Hz not available with 28.2 watt coil)  
**Watertight:** 24, 120, 240 volts AC, 60 Hz (or 110, 220 volts AC, 50 Hz) (238610); 120, 240 volts AC, 60 Hz (272610).  
**Optional High Ambient Temperature:** 140°F Class H coil with prefix HB for all valves except 8214093, add prefix HT.

## Solenoid Enclosures

**General Purpose:** RedHat metal Type 1 General Purpose Junction Box housing with two 7/8" knock-outs for 1/2" conduit connection.

**Watertight:** RedHat II molded epoxy Type 1, 2, 3, 3S, 4 and 4X combination. General Purpose and Watertight solenoid enclosures with 1/2" conduit hub as standard.

Optional: RedHat II - Explosionproof and Watertight, Types 3, 3S, 4, 4X, 6, 6P, 7, and 9. To order, add Prefix "EF" to catalog numbers. (e.g. EF8214G013)

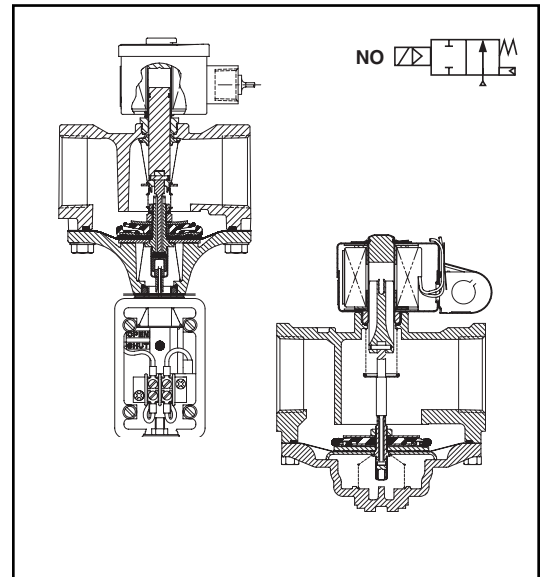
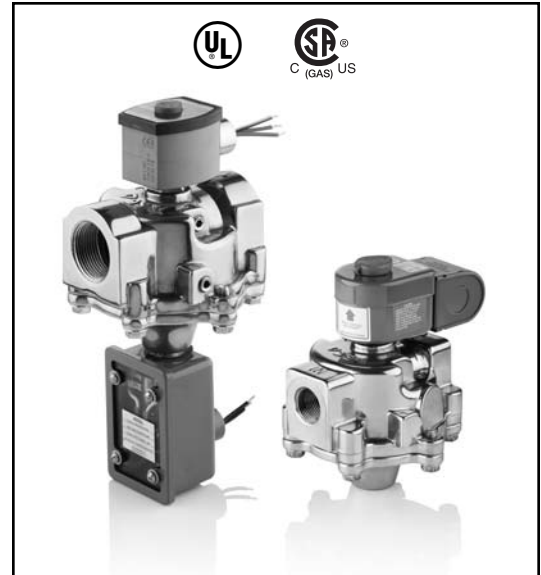

## Valve Response Time

**Opening Time:** Less than 1 second

**Closing Time:** Less than 1 second

## Approvals

UL listed to standard 429 "Electrically Operated Valves," Guide Y10Z, File MP618 General Purpose Valves.

CSA Certified to:

- 1) Standard C22.2 No. 139 "Electrically Operated Valves," File 010381.
- 2) Automatic Gas Valves Z21.21 (6.5), File 112872.

COMBUSTION

**Specifications - Standard (English units)**

Pipe Size (ins.)	Orifice Size (ins.)	Cv Flow Factor	Fuel Gas Capacity ① Btu/hr	Operating Pressure Differential (psi)		Max. Fluid Temp. °F	Catalog Number	Const. Ref.	Agency			Watt Rating	Approx. Shipping Weight (lbs)
				Min.	Max.				UL	FM	CSA		
<b>GENERAL PURPOSE</b>													
3/4	1 5/8	11	659,000	0	5	125	8214 037	1	●	-	●	20	4.3
1	1 5/8	21	1,179,000	0	5	125	8214 053	1	●	-	●	20	4.3
1 1/4	1 5/8	32	1,538,750	0	5	125	8214 063	2	●	-	●	20	4.3
1 1/2	1 5/8	35	1,615,250	0	5	125	8214 073	2	●	-	●	20	4.3
2	2 3/32	60	2,924,500	0	5	125	8214 083	3	●	-	●	20	6.3
2 1/2	3	109	6,022,750	0	5	125	8214 093	4	●	-	●	28.2	13.0
<b>WATERTIGHT</b>													
3/8	3/4	3.4	172,500	0	5	125	8214G013 ②	5	●	-	●	17.1	2.3
1/2	3/4	4.4	206,250	0	5	125	8214G023 ②	5	●	-	●	17.1	2.3
3/4	3/4	5.1	247,500	0	5	125	8214G033 ②	6	●	-	●	17.1	2.5
3/4	1 5/8	11	659,000	0	5	125	8214G038	7	●	-	●	20.1	4.3
1	1 5/8	21	1,179,000	0	5	125	8214G054	7	●	-	●	20.1	4.3
1 1/4	1 5/8	32	1,538,750	0	5	125	8214G064	8	●	-	●	20.1	4.3
1 1/2	1 5/8	35	1,615,250	0	5	125	8214G074	8	●	-	●	20.1	4.3
2	2 3/32	60	2,924,500	0	5	125	8214G084	9	●	-	●	20.1	6.3

○ = Safety Shutoff Valve. ① 1" W.C. Drop @ 2" W.C. Inlet Pressure, 1,000 Btu/cu.ft. or more, 0.64 Specific Gravity Gas. ② Single disc design used for valve sealing.

**Specifications - Standard (Metric units)**

Pipe Size (ins.)	Orifice Size (mm)	Kv Flow (m³/hr)	Fuel Gas Capacity ① Btu/hr	Operating Pressure Differential (bar)		Max. Fluid Temp. °C	Catalog Number	Const. Ref.	Agency			Watt Rating	Approx. Shipping Weight (kgs)
				Min.	Max.				UL	FM	CSA		
<b>GENERAL PURPOSE</b>													
3/4	41	9.4	659,000	0	0.3	52	8214 037	1	●	-	●	20	2.0
1	41	17.9	1,179,000	0	0.3	52	8214 053	1	●	-	●	20	2.0
1 1/4	41	27.2	1,538,750	0	0.3	52	8214 063	2	●	-	●	20	2.0
1 1/2	41	29.8	1,615,250	0	0.3	52	8214 073	2	●	-	●	20	2.0
2	53	51.0	2,924,500	0	0.3	52	8214 083	3	●	-	●	20	2.9
2 1/2	76	92.7	6,022,750	0	0.3	52	8214 093	4	●	-	●	28.2	5.9
<b>WATERTIGHT</b>													
3/8	19	2.9	172,500	0	0.3	52	8214G013 ②	5	●	-	●	17.1	1.0
1/2	19	3.7	206,250	0	0.3	52	8214G023 ②	5	●	-	●	17.1	1.0
3/4	19	4.3	247,500	0	0.3	52	8214G033 ②	6	●	-	●	17.1	1.1
3/4	41	9.4	659,000	0	0.3	52	8214G038	7	●	-	●	20.1	2.0
1	41	17.9	1,179,000	0	0.3	52	8214G054	7	●	-	●	20.1	2.0
1 1/4	41	27.2	1,538,750	0	0.3	52	8214G064	8	●	-	●	20.1	2.0
1 1/2	41	29.8	1,615,250	0	0.3	52	8214G074	8	●	-	●	20.1	2.0
2	53	51.0	2,924,500	0	0.3	52	8214G084	9	●	-	●	20.1	2.9

○ = Safety Shutoff Valve. ① 1" W.C. Drop @ 2" W.C. Inlet Pressure, 1,000 Btu/cu.ft. or more, 0.64 Specific Gravity Gas. ② Single disc design used for valve sealing.

## Specifications - Suffix C (English units)

Pipe Size (ins.)	Orifice Size (ins.)	Cv Flow Factor	Fuel Gas Capacity $\Phi$ Btu/hr	Operating Pressure Differential (psi)		Max. Fluid Temp. °F	Catalog Number	Const. Ref.	Agency			Watt Rating	Approx. Shipping Weight (lbs)
				Min.	Max.				UL	FM	CSA		
<b>GENERAL PURPOSE</b>													
3/4	1 5/8	11	659,000	0	5	125	8214 037C	10	●	-	●	20	4.8
1	1 5/8	21	1,179,000	0	5	125	8214 053C	10	●	-	●	20	4.8
1 1/4	1 5/8	32	1,538,750	0	5	125	8214 063C	11	●	-	●	20	4.8
1 1/2	1 5/8	35	1,615,250	0	5	125	8214 073C	11	●	-	●	20	4.8
2	2 3/32	60	2,924,500	0	5	125	8214 083C	12	●	-	●	20	6.8
<b>WATERTIGHT</b>													
3/4	1 5/8	11	659,000	0	5	125	8214G038C	13	●	-	●	20.1	4.8
1	1 5/8	21	1,179,000	0	5	125	8214G054C	13	●	-	●	20.1	4.8
1 1/4	1 5/8	32	1,538,750	0	5	125	8214G064C	14	●	-	●	20.1	4.8
1 1/2	1 5/8	35	1,615,250	0	5	125	8214G074C	14	●	-	●	20.1	4.8
2	2 3/32	60	2,924,500	0	5	125	8214G084C	15	●	-	●	20.1	6.8

○ = Safety Shutoff Valve.  $\Phi$  1" W.C. Drop @ 2" W.C. Inlet Pressure, 1,000 Btu/cu.ft. or more, 0.64 Specific Gravity Gas.

## Specifications - Suffix C (Metric units)

Pipe Size (ins.)	Orifice Size (mm)	Kv Flow (m <sup>2</sup> /hr)	Fuel Gas Capacity $\Phi$ Btu/hr	Operating Pressure Differential (bar)		Max. Fluid Temp. °C	Catalog Number	Const. Ref.	Agency			Watt Rating	Approx. Shipping Weight (kgs)
				Min.	Max.				UL	FM	CSA		
<b>GENERAL PURPOSE</b>													
3/4	41	9.4	659,000	0	0.3	52	8214 037C	10	●	-	●	20	2.2
1	41	17.9	1,179,000	0	0.3	52	8214 053C	10	●	-	●	20	2.2
1 1/4	41	27.2	1,538,750	0	0.3	52	8214 063C	11	●	-	●	20	2.2
1 1/2	41	29.8	1,615,250	0	0.3	52	8214 073C	11	●	-	●	20	2.2
2	53	51.0	2,924,500	0	0.3	52	8214 083C	12	●	-	●	20	3.1
<b>WATERTIGHT</b>													
3/4	41	9.4	659,000	0	0.3	52	8214G038C	13	●	-	●	20.1	4.8
1	41	17.9	1,179,000	0	0.3	52	8214G054C	13	●	-	●	20.1	4.8
1 1/4	41	27.2	1,538,750	0	0.3	52	8214G064C	14	●	-	●	20.1	4.8
1 1/2	41	29.8	1,615,250	0	0.3	52	8214G074C	14	●	-	●	20.1	4.8
2	53	51.0	2,924,500	0	0.3	52	8214G084C	15	●	-	●	20.1	6.8

○ = Safety Shutoff Valve.  $\Phi$  1" W.C. Drop @ 2" W.C. Inlet Pressure, 1,000 Btu/cu.ft. or more, 0.64 Specific Gravity Gas.

**Capabilities Chart**

Solenoid Options		Base Catalog Number	Resilient Materials	Standard Rebuild Kit
High Temp.	Junction Box	Aluminum	NBR	AC
<b>GENERAL PURPOSE</b>				
HB	JB	8214 037	●	316728
HB	JB	8214 053	●	316728
HB	JB	8214 063	●	316728
HB	JB	8214 073	●	316728
HB	JB	8214 083	●	316727
HT	JB	8214 093	●	316776
<b>WATERTIGHT</b>				
HB	JKP	8214G013	●	316234
HB	JKP	8214G023	●	316234
HB	JKP	8214G033	●	316234
HB	JKP	8214G038	●	322467
HB	JKP	8214G054	●	322467
HB	JKP	8214G064	●	322467
HB	JKP	8214G074	●	322467
HB	JKP	8214G084	●	322468
<b>GENERAL PURPOSE - SUFFIX C</b>				
HB	JB	8214 037C	●	Not Available
HB	JB	8214 053C	●	Not Available
HB	JB	8214 063C	●	Not Available
HB	JB	8214 073C	●	Not Available
HB	JB	8214 083C	●	Not Available
<b>WATERTIGHT - SUFFIX C</b>				
HB	JKP	8214G038C	●	Not Available
HB	JKP	8214G054C	●	Not Available
HB	JKP	8214G064C	●	Not Available
HB	JKP	8214G074C	●	Not Available
HB	JKP	8214G084C	●	Not Available

● = Standard. Other options may be available. All option combinations may not be available.

**Proof of Closure Switch (Suffix C)**

<b>Reed Switch</b>	SPST (closed when valve is in closed position.)
<b>Max. Electricity</b>	1 amp, 120 volts
<b>Load</b>	60 Hz, 15 watt (resistive)
<b>Leads</b>	18" long

**Note:** Switch is factory set and not to be field adjusted.

## Dimensions - General Purpose inches (mm)

Const. Ref.		A	B	C	E	H	J	K	L	M	N	P	R	T	W
1	ins.	2.69	4.59	1.88	2.69	6.79	3.53	2.19	5.00	2.50	6.16	3.59	2.62	2.20	5.39
	mm	68	117	48	68	172	90	56	127	64	156	91	67	56	137
2	ins.	2.69	4.59	1.88	2.69	6.79	3.53	2.13	5.00	2.50	6.16	3.53	2.62	2.20	5.39
	mm	68	117	48	68	172	90	54	127	64	156	90	67	56	137
3	ins.	3.16	4.59	1.88	3.16	7.39	3.53	2.38	6.09	2.50	6.34	3.78	2.81	2.20	6.32
	mm	80	117	48	80	188	90	60	155	64	161	96	71	56	161
4	ins.	3.82	5.72	1.88	4.13	10.33	4.07	3.07	7.80	3.07	7.97	5.13	3.89	3.31	3.95
	mm	97	145	48	105	262	103	78	198	78	202	130	99	84	100

Vent Valve Requirements	
Manifold Line	Vent Valve
3/8" through 1 1/2"	3/4
2"	1
2 1/2" through 3"	1 1/4
3 1/2"	1 1/2
4" through 5"	2
5 1/2" through 6"	2 1/2
6 1/2" through 7 1/2"	3

**Const. Ref. 1, 2**  
Must be mounted with solenoid vertical and upright.

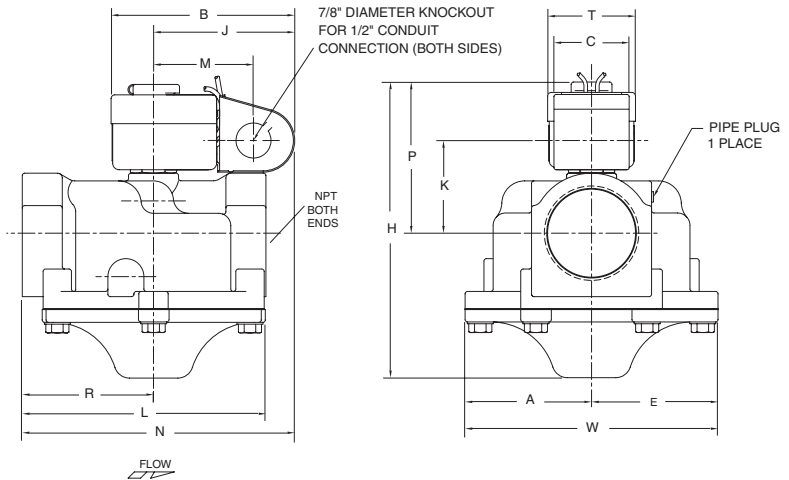

**Const. Ref. 3, 4**  
Must be mounted with solenoid vertical and upright.

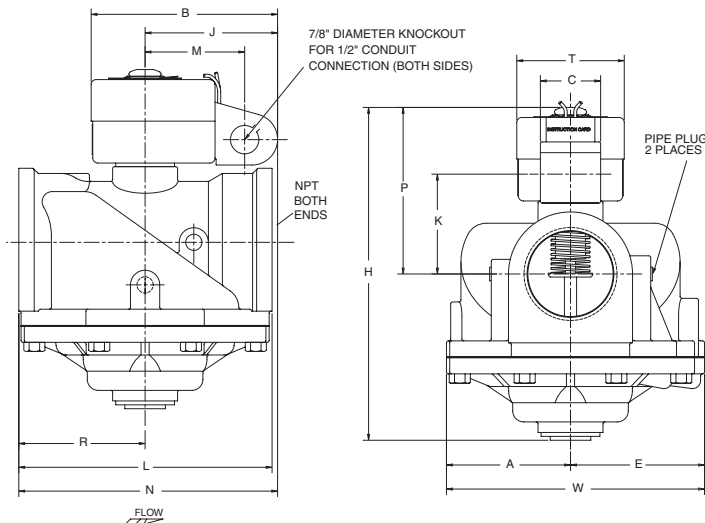

**Dimensions - Watertight inches (mm)**

Const. Ref.		A	B	E	H	J	K	L	N	P	R	T	W	Pipe Plug
1	ins.	1.14	3.03	1.36	4.48	2.04	2.72	2.75	3.42	3.86	1.38	1.95	2.50	B
	mm	29	77	35	114	52	69	70	87	98	35	50	64	B
2	ins.	1.14	3.03	1.25	5.92	2.04	2.90	3.31	3.70	4.04	1.66	1.95	2.39	A
	mm	29	77	32	150	52	74	84	94	103	42	50	61	A
3	ins.	2.69	3.11	2.69	6.74	2.05	2.33	5.00	4.67	3.54	2.62	2.06	5.39	-
	mm	68	79	68	171	52	59	127	119	90	67	52	137	-
4	ins.	2.69	3.11	2.69	6.74	2.05	2.27	5.00	4.67	3.48	2.62	2.06	5.39	-
	mm	68	79	68	171	52	58	127	119	88	67	52	137	-
5	ins.	3.16	3.11	3.16	7.34	2.05	2.52	6.09	4.67	3.73	3.28	2.06	6.32	-
	mm	80	79	80	186	52	64	155	119	95	83	52	161	-

Vent Valve Requirements	
Manifold Line	Vent Valve
3/8" through 1 1/2"	3/4
2"	1
2 1/2" through 3"	1 1/4
3 1/2"	1 1/2
4" through 5"	2
5 1/2" through 6"	2 1/2
6 1/2" through 7 1/2"	3

**Const. Ref. 5, 6**  
**Can be mounted in any position.**

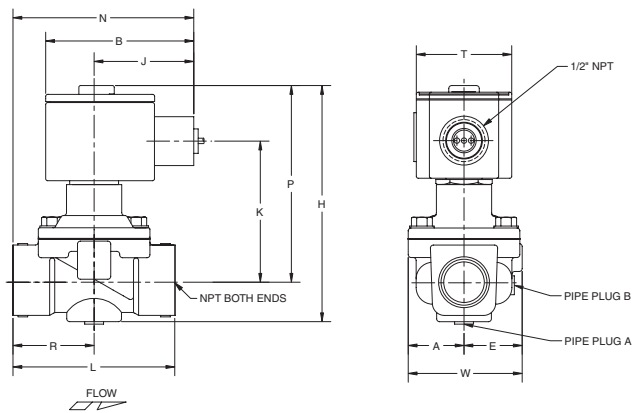

**Const. Ref. 7, 8, 9**  
**Must be mounted with solenoid vertical and upright.**

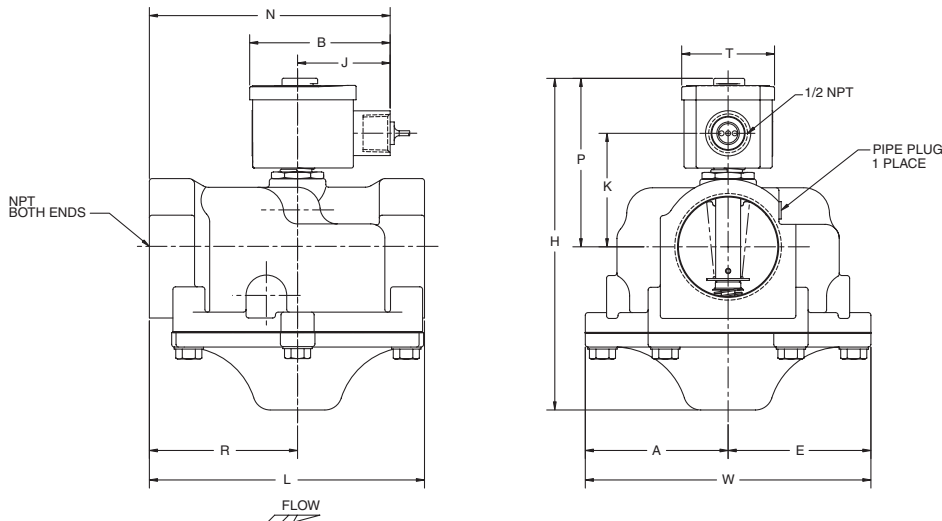

## Dimensions - General Purpose - Suffix C inches (mm)

Const. Ref.		A	B	C	F	G	H	J	K	L	M	N	P	R	T	U	W	Y
1	ins.	2.69	4.59	1.88	2.82	2.44	10.57	3.53	2.19	5.00	2.50	6.16	3.59	2.62	2.20	1.10	5.39	1.69
	mm	68	117	48	72	62	268	90	56	127	64	156	91	67	56	28	137	43
2	ins.	2.69	4.59	1.88	2.82	2.44	10.57	3.53	2.13	5.00	2.50	6.16	3.53	2.62	2.20	1.10	5.39	1.69
	mm	68	117	48	72	62	268	90	54	127	64	156	90	67	56	28	137	43
3	ins.	3.16	4.59	1.88	2.82	2.44	11.33	3.53	2.38	6.09	2.50	6.82	3.78	3.28	2.20	1.10	6.32	1.69
	mm	80	117	48	72	62	288	90	60	155	64	173	96	83	56	28	161	43

Vent Valve Requirements	
Manifold Line	Vent Valve
3/8" through 1 1/2"	3/4
2"	1
2 1/2" through 3"	1 1/4
3 1/2"	1 1/2
4" through 5"	2
5 1/2" through 6"	2 1/2
6 1/2" through 7 1/2"	3

**Const. Ref. 10, 11, 12**  
**Must be mounted with solenoid vertical and upright.**

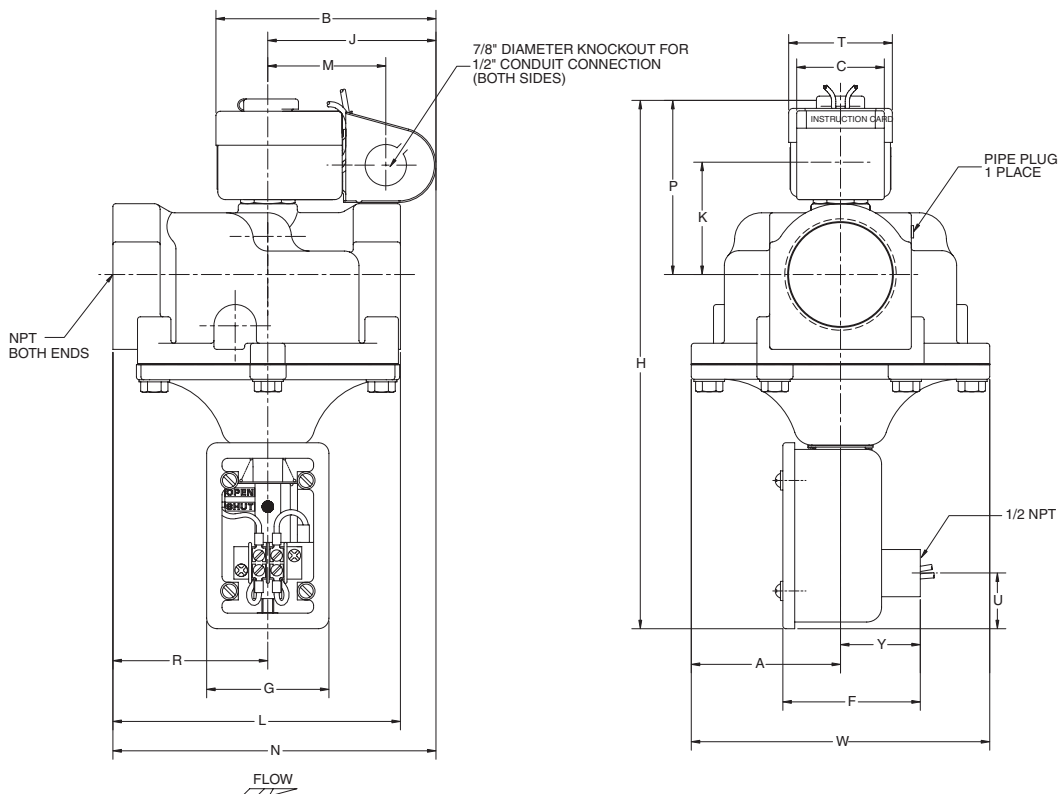

**Dimensions - Watertight Suffix C inches (mm)**

Const. Ref.		A	B	F	G	H	J	K	L	N	P	R	U	W	Y
1	ins.	2.69	3.11	3.07	2.32	10.54	2.05	4.06	5.00	4.67	5.46	2.62	1.18	5.39	1.69
	mm	68	79	78	59	268	52	103	127	119	139	67	30	137	43
2	ins.	2.69	3.11	3.07	2.32	10.54	2.05	4.13	5.00	4.67	5.53	2.62	1.18	5.39	1.69
	mm	68	79	78	59	268	52	105	127	119	140	67	30	137	43
3	ins.	3.16	3.11	3.07	2.32	11.33	2.05	4.62	6.09	5.33	5.84	3.28	1.18	6.32	1.69
	mm	80	79	78	59	288	52	117	155	135	148	83	30	161	43

Vent Valve Requirements	
Manifold Line	Vent Valve
3/8" through 1 1/2"	3/4
2"	1
2 1/2" through 3"	1 1/4
3 1/2"	1 1/2
4" through 5"	2
5 1/2" through 6"	2 1/2
6 1/2" through 7 1/2"	3

**Const. Ref. 13, 14, 15  
Must be mounted with solenoid vertical and upright.**

