

The Axial Flow Valve is a flexible element valve designed to control natural gas, air, nitrogen, carbon dioxide, propane vapor, other non-corrosive gases, or water over a wide range of flow rates.

General Information

- Inlet pressures up to 1480 PSIG
Outlet pressures range from 6" W.C. up to 900 PSIG
- Wide temperature range -20°F up to 150°F (Hydrin sleeve)
- Extended temperature ranges are available
- Maximum flow rate of 39,000,000 SCFH

Features

- Streamline Flow Path for quiet operation
- Sizes from 2" through 12"
- Compact Size and Light Weight
- Reversible sleeve
- Differential pressure drops up to 1000 PSID
- Stainless Steel Valve Cages

Applications

- Pressure reduction
- Relief valve
- Pressure reduction/monitor combination
- Two stage pressure reduction with monitor override
- On/Off control of flow
- Underpressure shutoff
- Flow Control
- Check Valve

Options

Reduced capacity cages for 2" Axial Flow Valves Only

- 2"R10 reduces capacity to 10%
- 2"R25 reduces capacity to 25%
- 2"R50 reduces capacity to 50%

Rated working pressures

- ANSI Class 300 Low Differential Pressure – 60 PSIG (5L Sleeve only)
- ANSI Class 300 – 740 PSIG. Available in 2"R10, 2"R25, 2"R50, 2", 3", 4", 6", 8", and 12"
- ANSI Class 600 – 1480 PSIG. Available in 2"R10, 2"R25, 2"R50, 2", 4", 6", and 8"

Lifting Plate

Provides a 1" x 1-1/2" aperture for engagement by hook, chain, or cable for lifting the Axial Flow Valve. The lifting plate attaches to the valve gallery utilizing the same two 5/16" x 2" bolts required for the manifold block.

Sleeve Material

Hydrin — Standard sleeve material for 300 Series Axial Flow Valves. Operating temperature range: -20°F to 150°F. Available in Durometer 50 – Low Delta Pressure (H-5L), Durometer 50 (H-5), Durometer 70 (H-7).

Buna N — Good chemical resistance. Operating temperature range: 0°F to 150°F. Available in Durometer 50 – Low Delta Pressure (B-5L), Durometer 50 (B-5), Durometer 70 (B-7). Standard in 600 Series high pressure Axial Flow Valves.

Viton — Excellent chemical resistance. Operating temperature range: 30°F to 180°F. Available in Durometer 70 (V-7).

Natural Rubber — Use in water applications only. Available in Durometer 70 (N-7).

Fluorosilicone Rubber — Good chemical resistance. Operating temperature range: -20°F to 180°F. Available in Durometer 50 (F-5). Limited to 125 PSIG inlet pressure.

HNBR — Maximum toughness for Buna applications. Operating temperature range: 0°F to 150°F. Available in Durometer 65 (HB-65).

Control Block Assemblies

Determines the differential pressure needed to operate the axial flow valve.

AFV Series	Sleeve Number	Composite Block Manifold Operating Parameters		Inspirator Block Manifold Operating Parameters		Maximum Operating Conditions	
		Cracking	Full Open	Cracking	Full Open	Continuous	Intermittent**
300	5L Hydrin Buna N	1.5 PSID	5 PSID	0.5 PSID	1.7 PSID	30 PSID	50 PSID
300	5 Hydrin Buna N	3.5 PSID	15 PSID	1.5 PSID	7.5 PSID	125 PSID	180 PSID
300	5 Fluorosilicone	2.0 PSID	10 PSID	N/A	N/A	60 PSID	60 PSID
300	7 Hydrin Buna N HNBR Viton Nat. Rubber	14 PSID	30 PSID	6 PSID	19 PSID	500 PSID	720 PSID
600*	7 Buna N (Std) Hydrin HNBR Viton	30 PSID	60 PSID	12 PSID	25 PSID	1000 PSID	1440 PSID

* Series 600 available in 2", 4", 6" and 8" only

** Intermittent is defined as total time in service < 30 days operating at this pressure differential

Options – Continued Pilots

Series Z Pilots

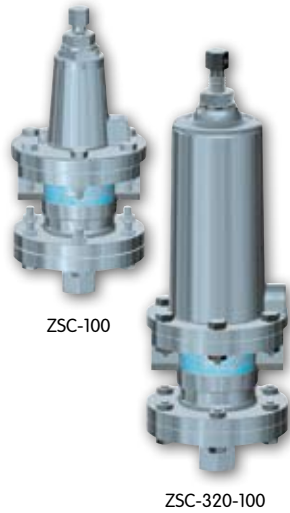

Z – Low pressure, (1 - 325 PSIG) pressure reducing

Z-138 – High pressure, (150 - 600 PSIG) pressure reducing

ZSC-100 – Low pressure, (1 - 325 PSIG) pressure reducing, secondary sense port

ZSC-320-100 – High pressure, (150 - 600 PSIG) pressure reducing, secondary sense port

ZSC-150 – Low pressure, (1 - 325 PSIG) relief service, secondary sense port

ZSC-320-150 – High pressure, (150 - 600 PSIG) relief service, secondary sense port

Pilot Type	Outlet Pressure	Spring Color Code	Part Number
Type Z, Type ZSC-100, Type ZCS-150	1 to 5 PSIG	Green	71411P010
	2 to 10 PSIG	Brown/Blue	71411P043
	3 to 30 PSIG	Yellow	71411P011
	10 to 75 PSIG	Red	71411P012
	25 to 150 PSIG	Blue	71411P014
	100 to 225 PSIG	White	71411P009
	200 to 325 PSIG	White/Red	71411P046
Type Z-138, Type ZSC-320-100, Type ZSC-320-150	150 to 600 PSIG	Gold	71421P008

60 Series Pilots



60L-PR – Low pressure (3 – 325 PSIG) pressure reducing

60L-RV – Low pressure (3 – 325 PSIG) relief service

60H-PR – High pressure (250-900 PSIG) pressure reducing

60H-RV – High pressure (250 – 900 PSIG) relief service

Pilot Type	Outlet Pressure	Spring Color Code	Part Number
Model 60L-PR, Model 60L-RV,	3 to 30 PSIG	Red	71411P055
	10 to 75 PSIG	Blue	71411P060
	25 to 150 PSIG	Black	71411P061
	100 to 325 PSIG	Green	71411P062
Model 60H-PR, Model 60H-RV	250 to 450 PSIG	Brown	71411P063
	400 to 900 PSIG	White	71411P064

1203 Pilots



1203 – Low pressure, (6" W.C. – 5 PSIG) pressure reducing

Pilot Type	Outlet Pressure	Spring Color Code	Part Number
1203, 125 PSIG Maximum Inlet Pressure	6" W.C. to 12" W.C.	Green	70017P001
	11" W.C. to 17" W.C.	Black/Orange	70017P002
	8" W.C. to 14" W.C.	Orange	70017P003
	14" W.C. to 2 PSIG	Black/Black	70017P073
	2 PSIG to 6 PSIG	Orange/Yellow	70017P078

Options – Continued

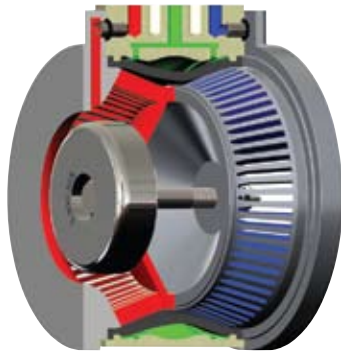

Capacity Limiter Kit:

Capacity Limiter Kits are available for 2", 3", 4" and 6" standard trim Axial Flow Valves. Capacity Limiters reduce the full-open capacity to a predetermined percentage of its rated capacity. Each kit consists of a bolt, spacer, and limiter. The flat faces of the limiter are stamped with a number that reads valve size, class rating, and percentage. For example, 2-300-75 is for a 2" valve, Class 300, and a reduction down to 75% of the full-open capacity. Capacity Limiters should not be used with 2" reduced capacity cages.

AFV Capacity Limiters

Valve Size	Percent of Full-Open Capacity	Class 300 Part Number	Class 600 Part Number
2"	50%	74075G036	74075G036
2"	75%	74075G041	74075G041
3"	50%	74075G055	N/A
3"	75%	74075G060	N/A
4"	50%	74075G074	74075G093
4"	75%	74075G079	74075G098
6"	50%	74075G112	N/A
6"	75%	74075G117	74075G124



1 Centering Tubes

Centering Tubes

Aligns the Axial Flow Valve to the pipe line centers during installation.

Valve Size	Quantity	Part Number
2"	2	73552P001
3"	2	73552P002
4"	2	73552P003
6"	2	73552P004
8"	2	73552P005
12"	2	73552P007



Flange Separator (300 Series Only):

Used to jack the flanges apart and relieve pipe strain to facilitate removal and replacement. (Two required)

Valve Size	Quantity	Part Number
2", 3" and 4"	2	73593G001
6" and 8"	2	73593G002
12"	2	73593G003

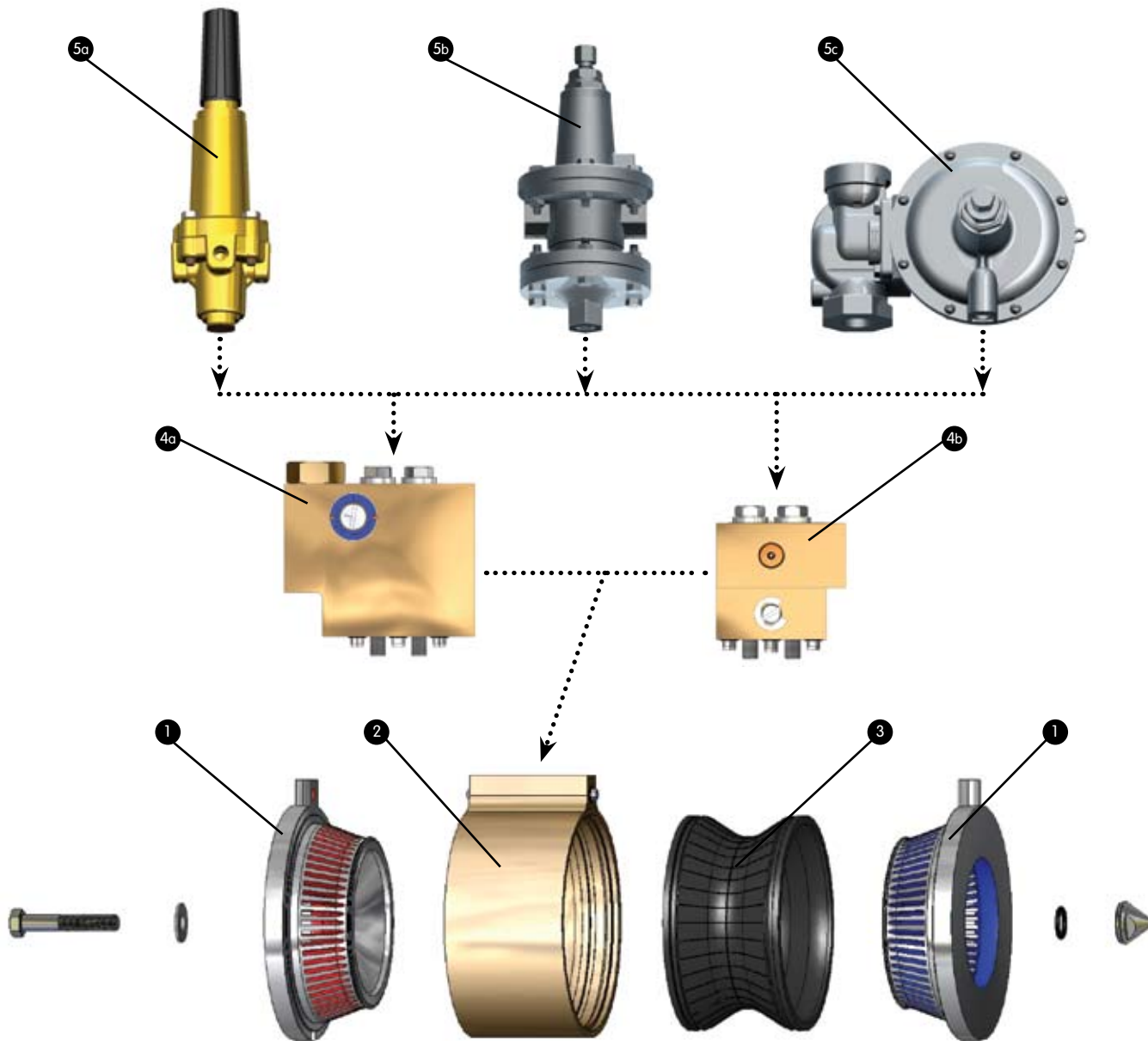

Material Specifications

- 1 Valve Cage Closure - 17-4 Stainless Steel.
- 2 Body Assembly - Carbon Steel, Electrodeposited zinc plating with chromate treatment.
- 3 Sleeve - Expansible material:
Hydrin (H)
Buna N (B)
Viton (V)
Natural Rubber (N)
Fluorosilicone Rubber (F)
NHBR (HB)
- 4a Control Block - Composite, with integral restrictor and filter assembly. Low restrictor setting causes Axial Flow Valve to open quickly and close slower. Higher setting causes Axial Flow Valve to open slowly and close quickly.
- 4b Control Block - Inspirator, with integral restrictor and filter assembly. Special nozzle reduces the differential pressure necessary to fully open the Axial Flow Valve.
- 5a Pilot Regulator - 60 Series
Inlet pressures up to 1480 PSIG.
Outlet pressures up to 900 PSIG.
- 5b Pilot Regulator - Series Z
Inlet pressures up to 1480 PSIG.
Outlet pressures up to 600 PSIG.
- 5c Pilot Regulator - 1203
Inlet pressures up to 125 PSIG.
Outlet pressures from 6" W.C. up to 5 PSIG.

Axial Flow Valve Capacity Performance

300 Series

Set Point 10 PSIG (0.69 bar)

MSCFH (m³/h) 0.60 specific gravity gas at 60°F and 14.7 PSIA (20°C and 1.02 bar)

Axial Flow Valve Capacity MSCFH (m³/h)

Inlet PSIG (bar)	2"R10	2"R25	2"R50	2"	3"	4"	6"	8"	12"
50 (3)	17.4 (493)	40.1 (1136)	78.9 (2234)	164 (4644)	303 (8580)	513 (14,527)	732 (20,728)	1203 (34,065)	2805 (79,429)
100 (7)	30.9 (875)	71.3 (2019)	140 (3964)	290 (8212)	537 (15,206)	909 (25,740)	1298 (36,755)	2133 (60,400)	4972 (140,791)
200 (14)	57.8 (1637)	133 (3766)	262 (7419)	543 (15,376)	1004 (28,430)	1701 (48,167)	2430 (68,810)	3992 (113,041)	9305 (263,488)
300 (21)	84.7 (2398)	195 (5522)	383 (10,845)	796 (22,540)	1472 (41,682)	2493 (70,594)	3561 (100,836)	5851 (165,682)	13,639 (386,214)
400 (28)	112 (3171)	258 (7306)	505 (14,300)	1048 (29,676)	1940 (54,935)	3285 (93,021)	4693 (132,891)	7710 (218,323)	17,973 (508,939)
500 (34)	139 (3936)	320 (9061)	627 (17,755)	1301 (36,840)	2407 (68,159)	4077 (115,448)	5825 (164,946)	9569 (270,964)	22,306 (631,636)
600 (41)	165 (4672)	382 (10,817)	749 (21,209)	1554 (44,004)	2875 (81,411)	4869 (137,875)	6956 (196,972)	11,428 (323,605)	26,640 (754,361)
740 (51)	203 (5748)	469 (13,281)	919 (26,023)	1908 (54,029)	3530 (99,958)	5978 (169,278)	8540 (241,826)	14,031 (397,314)	32,707 (926,159)

300 Series

Set Point 50 PSIG (3.45 bar)

MSCFH (m³/h) 0.60 specific gravity gas at 60°F and 14.7 PSIA (20°C and 1.02 bar)

Axial Flow Valve Capacity MSCFH (m³/h)

Inlet PSIG (bar)	2"R10	2"R25	2"R50	2"	3"	4"	6"	8"	12"
100 (7)	29.4 (833)	67.9 (1923)	135 (3823)	285 (8070)	536 (15,178)	908 (25,712)	1296 (36,699)	2133 (60,400)	4913 (139,121)
200 (14)	57.8 (1637)	133 (3766)	262 (7419)	543 (15,376)	1004 (28,430)	1701 (48,167)	2430 (68,810)	3992 (113,041)	9305 (263,488)
300 (21)	84.7 (2398)	195 (5522)	383 (10,845)	796 (22,540)	1472 (41,682)	2493 (70,594)	3561 (100,836)	5851 (165,682)	13,639 (386,214)
400 (28)	112 (3171)	258 (7306)	505 (14,300)	1048 (29,676)	1940 (54,935)	3285 (93,021)	4693 (132,891)	7710 (218,323)	17,973 (508,939)
500 (34)	139 (3936)	320 (9061)	627 (17,755)	1301 (36,840)	2407 (68,159)	4077 (115,448)	5825 (164,946)	9569 (270,964)	22,306 (631,636)
600 (41)	165 (4672)	382 (10,817)	749 (21,209)	1554 (44,004)	2875 (81,411)	4869 (137,875)	6956 (196,972)	11,428 (323,605)	26,640 (754,361)
740 (51)	203 (5748)	469 (13,281)	919 (26,023)	1908 (54,029)	3530 (99,958)	5978 (169,278)	8540 (241,826)	14,031 (397,314)	32,707 (926,159)

Axial Flow Valve Capacity Performance

300 Series

Set Point 100 PSIG (6.89 bar)

MSCFH (m³/h) 0.60 specific gravity gas at 60°F and 14.7 PSIA (20°C and 1.02 bar)

Axial Flow Valve Capacity MSCFH (m³/h)

Inlet PSIG (bar)	2"R10	2"R25	2"R50	2"	3"	4"	6"	8"	12"
200 (14)	55.8 (1580)	129 (3653)	256 (7249)	538 (15,234)	1004 (28,430)	1701 (48,167)	2430 (68,810)	3992 (113,041)	9255 (262,072)
300 (21)	84.6 (2396)	195 (5522)	383 (10,845)	796 (22,540)	1472 (41,682)	2493 (70,594)	3561 (100,836)	5851 (165,682)	13,639 (386,214)
400 (28)	112 (3171)	258 (7306)	505 (14,300)	1048 (29,676)	1940 (54,935)	3285 (93,021)	4693 (132,891)	7710 (218,323)	17,973 (508,939)
500 (34)	139 (3936)	320 (9061)	627 (17,755)	1301 (36,840)	2407 (68,159)	4077 (115,448)	5825 (164,946)	9569 (270,964)	22,306 (631,636)
600 (41)	165 (4672)	382 (10,817)	749 (21,209)	1554 (44,004)	2875 (81,411)	4869 (137,875)	6956 (196,972)	11,428 (323,605)	26,640 (754,361)
740 (51)	203 (5748)	469 (13,281)	919 (26,023)	1908 (54,029)	3530 (99,958)	5978 (169,278)	8540 (241,826)	14,031 (397,314)	32,707 (926,159)

300 Series

Set Point 200 PSIG (13.79 bar)

MSCFH (m³/h) 0.60 specific gravity gas at 60°F and 14.7 PSIA (20°C and 1.02 bar)

Axial Flow Valve Capacity MSCFH (m³/h)

Inlet PSIG (bar)	2"R10	2"R25	2"R50	2"	3"	4"	6"	8"	12"
300 (21)	74.3 (2104)	172 (4870)	345 (9769)	733 (20,756)	1415 (40,068)	2406 (68,130)	3416 (96,730)	5710 (161,689)	12,701 (359,652)
400 (28)	108 (3058)	250 (7079)	497 (14,073)	1042 (29,506)	1940 (54,935)	3285 (93,021)	4693 (132,891)	7710 (218,323)	17,918 (507,381)
500 (34)	138 (3908)	318 (9005)	627 (17,755)	1301 (36,840)	2407 (68,159)	4077 (115,448)	5825 (164,946)	9569 (270,964)	22,306 (631,636)
600 (41)	165 (4672)	382 (10,817)	749 (21,209)	1554 (44,004)	2875 (81,411)	4869 (137,875)	6956 (196,972)	11,428 (323,605)	26,640 (754,361)
740 (51)	203 (5748)	469 (13,281)	919 (26,023)	1908 (54,029)	3530 (99,958)	5978 (169,278)	8540 (241,826)	14,031 (397,314)	32,707 (926,159)

300 Series

Set Point 300 PSIG (20.68 bar)

MSCFH (m³/h) 0.60 specific gravity gas at 60°F and 14.7 PSIA (20°C and 1.02 bar)

Axial Flow Valve Capacity MSCFH (m³/h)

Inlet PSIG (bar)	2"R10	2"R25	2"R50	2"	3"	4"	6"	8"	12"
400 (28)	89.3 (2529)	206 (5833)	417 (11,808)	890 (25,202)	1743 (49,356)	2969 (84,073)	4205 (119,072)	7092 (200,823)	15,469 (438,033)
500 (34)	129 (3653)	297 (8410)	594 (16,820)	1254 (35,509)	2386 (67,564)	4048 (114,627)	5766 (163,275)	9546 (270,313)	21,675 (613,768)
600 (41)	161 (4559)	372 (10,534)	739 (20,926)	1546 (43,778)	2875 (81,411)	4869 (137,875)	6956 (196,972)	11,428 (323,605)	26,577 (752,577)
740 (51)	202 (5720)	467 (13,224)	919 (26,023)	1908 (54,029)	3530 (99,958)	5978 (169,278)	8540 (241,826)	14,031 (397,314)	32,707 (926,159)

Axial Flow Valve Capacity Performance

300 Series

Set Point 400 PSIG (27.58 bar)

MSCFH (m³/h) 0.60 specific gravity
gas at 60°F and 14.7 PSIA (20°C and
1.02 bar)

Axial Flow Valve Capacity MSCFH (m³/h)

Inlet PSIG (bar)	2"R10	2"R25	2"R50	2"	3"	4"	6"	8"	12"
500 (34)	102 (2888)	236 (6683)	478 (13,535)	1024 (28,996)	2023 (57,285)	3449 (97,665)	4877 (138,101)	8266 (234,067)	17,839 (505,144)
600 (41)	146 (4134)	337 (9543)	678 (19,199)	1440 (40,776)	2776 (78,608)	4719 (133,627)	6704 (189,836)	11,195 (317,007)	24,950 (706,505)
740 (51)	195 (5522)	450 (12,743)	896 (25,372)	1883 (53,321)	3528 (99,902)	5978 (169,278)	8535 (241,684)	14,031 (397,314)	32,433 (918,400)

300 Series

Set Point 500 PSIG (34.47 bar)

MSCFH (m³/h) 0.60 specific gravity
gas at 60°F and 14.7 PSIA (20°C and
1.02 bar)

Axial Flow Valve Capacity MSCFH (m³/h)

Inlet PSIG (bar)	2"R10	2"R25	2"R50	2"	3"	4"	6"	8"	12"
600 (41)	114 (3228)	262 (7419)	533 (15,093)	1144 (32,394)	2270 (64,279)	3873 (109,671)	5472 (154,950)	9303 (263,432)	19,941 (564,666)
740 (51)	178 (5040)	411 (11,638)	827 (23,418)	1758 (49,781)	3393 (96,079)	5769 (163,360)	8194 (232,028)	13,696 (387,828)	30,463 (862,616)

600 Series

Set Point 50 PSIG (3.45 bar)

MSCFH (m³/h) 0.60 specific gravity
gas at 60°F and 14.7 PSIA (20°C and
1.02 bar)

Axial Flow Valve Capacity MSCFH (m³/h)

Inlet PSIG (bar)	2"R10	2"R25	2"R50	2"	4"	6"	8"
100 (7)	27 (765)	67 (1894)	152 (4304)	290 (8212)	1063 (30,101)	2023 (57,285)	2963 (83,903)
200 (14)	53 (1501)	133 (3766)	291 (8240)	552 (15,631)	2024 (57,313)	3798 (107,547)	5595 (158,433)
300 (21)	78 (2209)	196 (5550)	427 (12,091)	809 (22,908)	2967 (84,016)	5567 (157,640)	8201 (232,227)
400 (28)	103 (2917)	258 (7306)	562 (15,914)	1066 (30,186)	3910 (110,719)	7336 (207,732)	10,807 (306,020)
500 (34)	128 (3625)	320 (9061)	698 (19,765)	1323 (37,463)	4852 (137,393)	9104 (257,797)	13,413 (379,814)
600 (41)	153 (4332)	382 (10,817)	834 (23,616)	1580 (44,741)	5795 (164,096)	10,873 (307,889)	16,018 (453,579)
700 (48)	178 (5040)	444 (12,573)	969 (27,439)	1837 (52,018)	6738 (190,799)	12,642 (357,982)	18,624 (527,373)
800 (55)	202 (5720)	506 (14,328)	1105 (31,290)	2094 (59,295)	7680 (217,473)	14,411 (408,074)	21,230 (601,167)
900 (62)	227 (6428)	568 (16,084)	1240 (35,113)	2351 (66,573)	8623 (244,176)	16,180 (458,167)	23,836 (674,960)
1000 (69)	252 (7136)	631 (17,868)	1376 (38,964)	2607 (73,822)	9566 (270,879)	17,948 (508,231)	26,441 (748,726)
1100 (76)	277 (7844)	693 (19,624)	1512 (42,815)	2864 (81,099)	10,509 (297,582)	19,717 (558,323)	29,047 (822,520)
1200 (83)	302 (8552)	755 (21,379)	1647 (46,638)	3121 (88,377)	11,451 (324,256)	21,486 (608,416)	31,653 (896,313)
1300 (90)	327 (9260)	817 (23,135)	1783 (50,489)	3378 (95,654)	12,394 (350,959)	23,255 (658,508)	34,259 (970,107)

Axial Flow Valve Capacity Performance

600 Series

Set Point 100 PSIG (6.89 bar)

MSCFH (m³/h) 0.60 specific gravity gas at 60°F and 14.7 PSIA (20°C and 1.02 bar)

Axial Flow Valve Capacity MSCFH (m³/h)

Inlet PSIG (bar)	2"R10	2"R25	2"R50	2"	4"	6"	8"
200 (14)	52 (1472)	127 (3596)	287 (8127)	547 (15,489)	2005 (56,775)	3796 (107,491)	5576 (157,895)
300 (21)	78 (2209)	195 (5522)	427 (12,091)	809 (22,908)	2967 (84,016)	5567 (157,640)	8201 (232,227)
400 (28)	103 (2917)	258 (7306)	562 (15,914)	1066 (30,186)	3910 (110,719)	7336 (207,732)	10,807 (306,020)
500 (34)	128 (3625)	320 (9061)	698 (19,765)	1323 (37,463)	4852 (137,393)	9104 (257,797)	13,413 (379,814)
600 (41)	153 (4332)	382 (10,817)	834 (23,616)	1580 (44,741)	5795 (164,096)	10,873 (307,889)	16,018 (453,579)
700 (48)	178 (5040)	444 (12,573)	969 (27,439)	1837 (52,018)	6738 (190,799)	12,642 (357,982)	18,624 (527,373)
800 (55)	202 (5720)	506 (14,328)	1105 (31,290)	2094 (59,295)	7680 (217,473)	14,411 (408,074)	21,230 (601,167)
900 (62)	227 (6428)	568 (16,084)	1240 (35,113)	2351 (66,573)	8623 (244,176)	16,180 (458,167)	23,836 (674,960)
1000 (69)	252 (7136)	631 (17,868)	1376 (38,964)	2607 (73,822)	9566 (270,879)	17,948 (508,231)	26,441 (748,726)
1100 (76)	277 (7844)	693 (19,624)	1512 (42,815)	2864 (81,099)	10,509 (297,582)	19,717 (558,323)	29,047 (822,520)
1200 (83)	302 (8552)	755 (21,379)	1647 (46,638)	3121 (88,377)	11,451 (324,256)	21,486 (608,416)	31,653 (896,313)
1300 (90)	327 (9260)	817 (23,135)	1783 (50,489)	3378 (95,654)	12,394 (350,959)	23,255 (658,508)	34,259 (970,107)

600 Series

Set Point 200 PSIG (13.79 bar)

MSCFH (m³/h) 0.60 specific gravity gas at 60°F and 14.7 PSIA (20°C and 1.02 bar)

Axial Flow Valve Capacity MSCFH (m³/h)

Inlet PSIG (bar)	2"R10	2"R25	2"R50	2"	4"	6"	8"
300 (21)	69 (1954)	168 (4757)	388 (10,987)	745 (21,096)	2733 (77,390)	5305 (150,221)	7687 (217,672)
400 (28)	100 (2832)	247 (6994)	556 (15,744)	1059 (29,988)	3886 (110,039)	7336 (207,732)	10,789 (305,511)
500 (34)	127 (3596)	316 (8948)	698 (19,765)	1323 (37,463)	4852 (137,393)	9104 (257,797)	13,413 (379,814)
600 (41)	153 (4332)	381 (10,789)	834 (23,616)	1580 (44,741)	5795 (164,096)	10,873 (307,889)	16,018 (453,579)
700 (48)	178 (5040)	444 (12,573)	969 (27,439)	1837 (52,018)	6738 (190,799)	12,642 (357,982)	18,624 (527,373)
800 (55)	202 (5720)	506 (14,328)	1105 (31,290)	2094 (59,295)	7680 (217,473)	14,411 (408,074)	21,230 (601,167)
900 (62)	227 (6428)	568 (16,084)	1240 (35,113)	2351 (66,573)	8623 (244,176)	16,180 (458,167)	23,836 (674,960)
1000 (69)	252 (7136)	631 (17,868)	1376 (38,964)	2607 (73,822)	9566 (270,879)	17,948 (508,231)	26,441 (748,726)
1100 (76)	277 (7844)	693 (19,624)	1512 (42,815)	2864 (81,099)	10,509 (297,582)	19,717 (558,323)	29,047 (822,520)
1200 (83)	302 (8552)	755 (21,379)	1647 (46,638)	3121 (88,377)	11,451 (324,256)	21,486 (608,416)	31,653 (896,313)
1300 (90)	327 (9260)	817 (23,135)	1783 (50,489)	3378 (95,654)	12,394 (350,959)	23,255 (658,508)	34,259 (970,107)

Axial Flow Valve Capacity Performance

600 Series

Set Point 300 PSIG (20.68 bar)

MSCFH (m³/h) 0.60 specific gravity
gas at 60°F and 14.7 PSIA (20°C and
1.02 bar)

Axial Flow Valve Capacity MSCFH (m³/h)

Inlet PSIG (bar)	2"R10	2"R25	2"R50	2"	4"	6"	8"
400 (28)	82 (2322)	201 (5692)	469 (13,281)	904 (25,598)	3318 (93,955)	6512 (184,399)	9381 (265,640)
500 (34)	119 (3370)	292 (8269)	666 (18,859)	1275 (36,104)	4678 (132,466)	8980 (254,285)	13,092 (370,724)
600 (41)	149 (4219)	367 (10,392)	826 (23,390)	1571 (44,486)	5765 (163,247)	10,873 (307,889)	15,998 (453,013)
700 (48)	176 (4984)	437 (12,374)	968 (27,411)	1837 (52,018)	6738 (190,799)	12,642 (357,982)	18,624 (527,373)
800 (55)	202 (5720)	503 (14,243)	1105 (31,290)	2094 (59,295)	7680 (217,473)	14,411 (408,074)	21,230 (601,167)
900 (62)	227 (6428)	567 (16,056)	1240 (35,113)	2351 (66,573)	8623 (244,176)	16,180 (458,167)	23,836 (674,960)
1000 (69)	252 (7136)	630 (17,840)	1376 (38,964)	2607 (73,822)	9566 (270,879)	17,948 (508,231)	26,441 (748,726)
1100 (76)	277 (7844)	693 (19,624)	1512 (42,815)	2864 (81,099)	10,509 (297,582)	19,717 (558,323)	29,047 (822,520)
1200 (83)	302 (8552)	755 (21,379)	1647 (46,638)	3121 (88,377)	11,451 (324,256)	21,486 (608,416)	31,653 (896,313)
1300 (90)	327 (9260)	817 (23,135)	1783 (50,489)	3378 (95,654)	12,394 (350,959)	23,255 (658,508)	34,259 (970,107)

600 Series

Set Point 400 PSIG (27.58 bar)

MSCFH (m³/h) 0.60 specific gravity
gas at 60°F and 14.7 PSIA (20°C and
1.02 bar)

Axial Flow Valve Capacity MSCFH (m³/h)

Inlet PSIG (bar)	2"R10	2"R25	2"R50	2"	4"	6"	8"
500 (34)	94 (2662)	230 (6513)	540 (15,291)	1041 (29,478)	3820 (108,170)	7542 (213,566)	10,830 (306,672)
600 (41)	135 (3823)	331 (9373)	763 (21,606)	1464 (41,456)	5370 (152,061)	10,413 (294,863)	15,098 (427,528)
700 (48)	168 (4757)	413 (11,695)	939 (26,590)	1795 (50,829)	6584 (186,438)	12,570 (355,943)	18,379 (520,435)
800 (55)	197 (5578)	488 (13,819)	1095 (31,007)	2084 (59,012)	7644 (216,454)	14,411 (408,074)	21,207 (600,515)
900 (62)	225 (6371)	557 (15,772)	1239 (35,085)	2349 (66,516)	8619 (244,063)	16,180 (458,167)	23,836 (674,960)
1000 (69)	251 (7108)	625 (17,698)	1376 (38,964)	2607 (73,822)	9566 (270,879)	17,948 (508,231)	26,441 (748,726)
1100 (76)	277 (7844)	690 (19,539)	1512 (42,815)	2864 (81,099)	10,509 (297,582)	19,717 (558,323)	29,047 (822,520)
1200 (83)	302 (8552)	754 (21,351)	1647 (46,638)	3121 (88,377)	11,451 (324,256)	21,486 (608,416)	31,653 (896,313)
1300 (90)	327 (9260)	817 (23,135)	1783 (50,489)	3378 (95,654)	12,394 (350,959)	23,255 (658,508)	34,259 (970,107)

Axial Flow Valve Capacity Performance

600 Series

Set Point 500 PSIG (34.47 bar)

MSCFH (m³/h) 0.60 specific gravity
gas at 60°F and 14.7 PSIA (20°C and
1.02 bar)

Axial Flow Valve Capacity MSCFH (m³/h)

Inlet PSIG (bar)	2"R10	2"R25	2"R50	2"	4"	6"	8"
600 (41)	105 (2973)	255 (7221)	602 (17,047)	1163 (32,932)	4266 (120,800)	8454 (239,391)	12,115 (343,059)
700 (48)	150 (4248)	366 (10,364)	849 (24,041)	1633 (46,241)	5990 (169,618)	11,694 (331,137)	16,894 (478,385)
800 (55)	185 (5239)	455 (12,884)	1042 (29,506)	1997 (56,549)	7325 (207,421)	14,109 (399,522)	20,531 (581,373)
900 (62)	217 (6145)	534 (15,121)	1210 (34,263)	2311 (65,440)	8477 (240,042)	16,133 (456,836)	23,629 (669,099)
1000 (69)	246 (6966)	608 (17,217)	1364 (38,624)	2596 (73,511)	9523 (269,661)	17,948 (508,231)	26,416 (748,018)
1100 (76)	274 (7759)	678 (19,199)	1508 (42,702)	2863 (81,071)	10,502 (297,384)	19,717 (558,323)	29,047 (822,520)
1200 (83)	300 (8495)	746 (21,124)	1647 (46,638)	3121 (88,377)	11,451 (324,256)	21,486 (608,416)	31,653 (896,313)
1300 (90)	326 (9231)	812 (22,993)	1783 (50,489)	3378 (95,654)	12,394 (350,959)	23,255 (658,508)	34,259 (970,107)

600 Series

Set Point 600 PSIG (41.37 bar)

MSCFH (m³/h) 0.60 specific gravity
gas at 60°F and 14.7 PSIA (20°C and
1.02 bar)

Axial Flow Valve Capacity MSCFH (m³/h)

Inlet PSIG (bar)	2"R10	2"R25	2"R50	2"	4"	6"	8"
700 (48)	115 (3256)	278 (7872)	658 (18,632)	1273 (36,047)	4670 (132,240)	9280 (262,780)	13,280 (376,048)
800 (55)	163 (4616)	398 (11,270)	928 (26,278)	1787 (50,602)	6557 (185,674)	12,860 (364,155)	18,531 (524,740)
900 (62)	201 (5692)	493 (13,960)	1137 (32,196)	2182 (61,787)	8007 (226,733)	15,521 (439,506)	22,507 (637,327)
1000 (69)	235 (6654)	577 (16,339)	1317 (37,293)	2521 (71,387)	9247 (261,846)	17,735 (502,199)	25,867 (732,471)
1100 (76)	266 (7532)	655 (18,548)	1481 (41,937)	2825 (79,995)	10,365 (293,504)	19,685 (557,417)	28,864 (817,338)
1200 (83)	294 (8325)	728 (20,615)	1633 (46,241)	3108 (88,009)	11,403 (322,897)	21,486 (608,416)	31,624 (895,492)
1300 (90)	322 (9118)	798 (22,597)	1778 (50,347)	3376 (95,598)	12,384 (350,676)	23,255 (658,508)	34,259 (970,107)

600 Series

Set Point 700 PSIG (48.26 bar)

MSCFH (m³/h) 0.60 specific gravity
gas at 60°F and 14.7 PSIA (20°C and
1.02 bar)

Axial Flow Valve Capacity MSCFH (m³/h)

Inlet PSIG (bar)	2"R10	2"R25	2"R50	2"	4"	6"	8"
800 (55)	124 (3511)	300 (8495)	710 (20,105)	1375 (38,936)	5043 (142,802)	10,041 (284,330)	14,354 (406,460)
900 (62)	175 (4955)	428 (12,120)	1001 (28,345)	1930 (54,652)	7081 (200,512)	13,937 (394,652)	20,045 (567,611)
1000 (69)	216 (6116)	529 (14,980)	1225 (34,688)	2355 (66,686)	8640 (244,658)	16,829 (476,544)	24,342 (689,289)
1100 (76)	252 (7136)	617 (17,471)	1417 (40,125)	2717 (76,937)	9967 (282,234)	19,227 (544,448)	27,954 (791,569)
1200 (83)	284 (8042)	699 (19,793)	1591 (45,052)	3040 (86,083)	11,154 (315,846)	21,327 (603,914)	31,158 (882,296)
1300 (90)	314 (8891)	775 (21,946)	1751 (49,583)	3339 (94,550)	12,250 (346,881)	23,230 (657,800)	34,091 (965,350)

Axial Flow Valve Dimensions

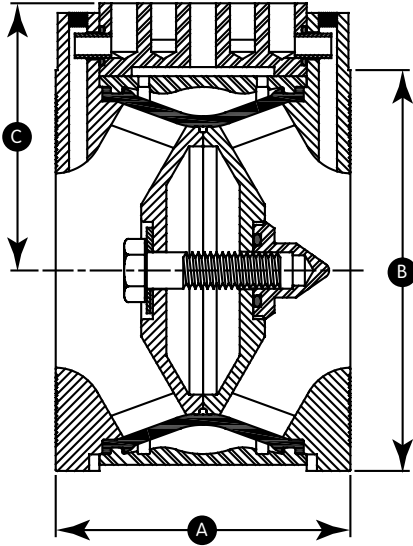

300 Series

Valve Size (inches)	Dimensions			Weight
	A	B	C	
2R10, 2R25, 2R50, 2"	3-1/32" 77mm	4-1/8" 104.8mm	2-3/4" 69.9mm	5-3/4 lb 2.6 kg
3"	3-23/32" 94.5mm	5-3/8" 136.5mm	3-5/16" 84.1mm	9 lb 4.1 kg
4"	4-1/2" 114.3mm	6-7/8" 174.6mm	4-1/8" 104.8mm	19 lb 8.6 kg
6"	5-1/2" 139.7mm	8-3/4" 222.3mm	5-1/16" 128.6mm	38 lb 17.2 kg
8"	6-23/32" 170.6mm	11" 279.4mm	6-3/16" 157.2mm	80 lb 36.3 kg
12"	9-7/16" 239.7mm	16-1/8" 409.6mm	8-3/4" 222.3mm	177 lb 80.3 kg

600 Series

Valve Size (inches)	Dimensions			Weight
	A	B	C	
2R10, 2R25, 2R50, 2"	3-13/32" 86.5mm	4-3/8" 111.1mm	2-7/8" 73.0mm	7-1/2 lb 3.4 kg
4"	5-1/4" 133.4mm	7-5/8" 193.7mm	4-1/2" 114.3mm	31-1/2 lb 14.3 kg
6"	6-7/8" 174.6mm	10-1/2" 266.7mm	5-7/8" 149.2mm	73-1/2 lb 33.3 kg
8"	8-5/64" 205.2mm	12-5/8" 320.7mm	7" 177.8mm	122 lb 55.3 kg

Axial Flow Valve Dimensions

Control Loop Dimensions

Pilot Type	A	B	C	D	Weight
ZSC-100	8-7/8" 225.4 mm	5-3/16" 131.8 mm	4-1/16" 103.2 mm	7-1/4" 184.2 mm	13-3/4 lb 6.2 kg
ZSC-320-100	8-7/8" 225.4 mm	10-1/16" 255.6 mm	4-1/16" 103.2 mm	7-1/4" 184.2 mm	16-1/4 lb 7.4 kg
ZSC-150	8-7/8" 225.4 mm	6-1/4" 158.8 mm	4-1/16" 103.2 mm	7-1/4" 184.2 mm	13-3/4 lb 6.2 kg
ZSC-320-150	8-7/8" 225.4 mm	10-13/16" 274.6 mm	4-1/16" 103.2 mm	7-1/4" 184.2 mm	16-1/4 lb 7.4 kg
1203-180	9-1/8" 231.8 mm	6-5/16" 160.3 mm	10-1/4" 260.4 mm	—	7-3/4 lb 3.5 kg
60 Series - 60L	8-1/16" 204.8 mm	8-1/8" 209.6 mm	4-1/4" 108.0 mm	7" 177.8 mm	11-1/4 lb 5.1 kg
60 Series - 60H	8-1/16" 204.8 mm	8-1/8" 209.6 mm	4-1/4" 108.0 mm	7" 177.8 mm	11-1/2 lb 5.3 kg

ZSC 100 Control Loop

ZSC 320 - 100 Control Loop

1203 Control Loop

60 Series Control Loop

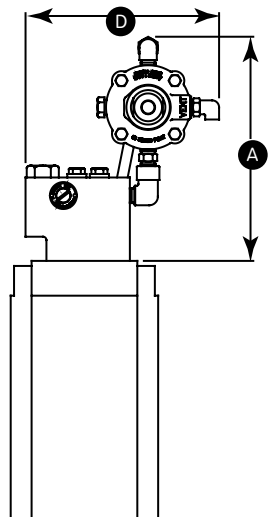
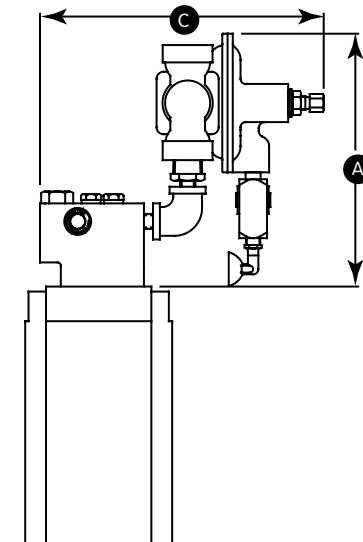
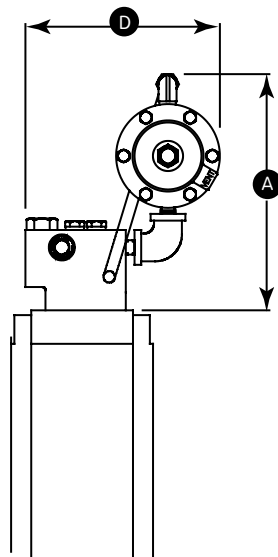
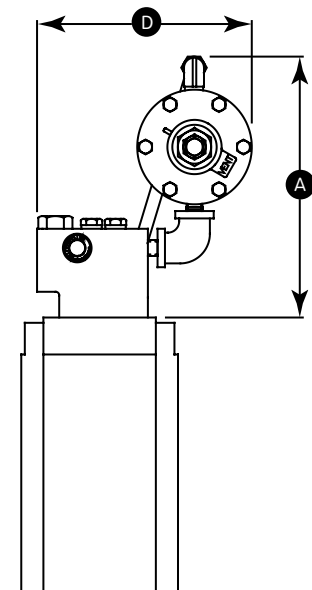
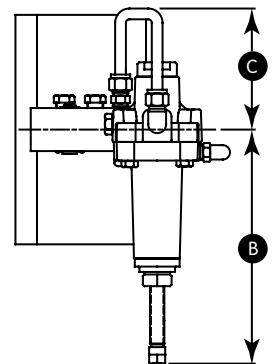
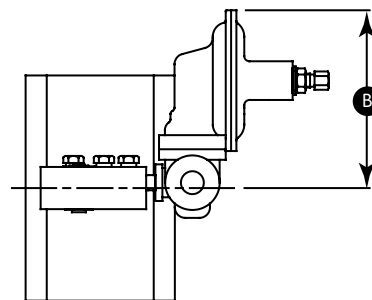
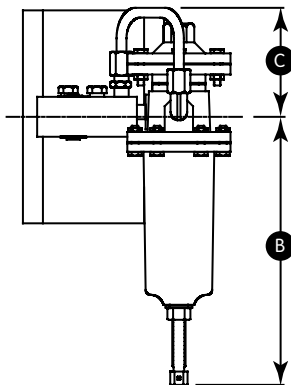
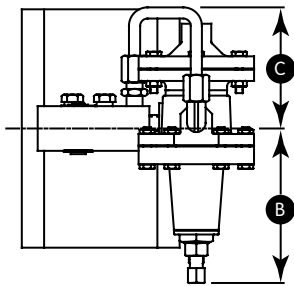

Assembly Positions

Pressure Reduction

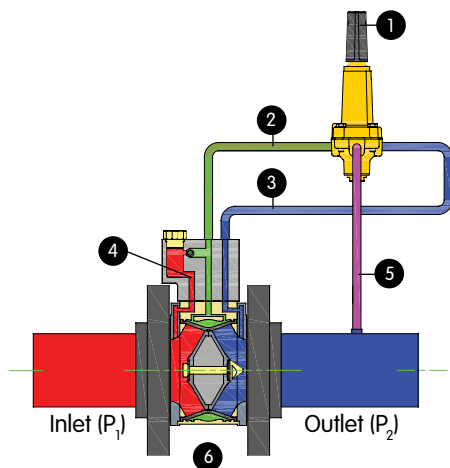

Pressure Reduction

When outlet pressure decreases, the pilot opens further. This results in a higher flow through the downstream bleed thereby reducing the control pressure on the outside of the sleeve. Inlet pressure is now much greater than the control pressure and the Axial Flow Valve opens wider to restore downstream pressure.

Pressure Relief

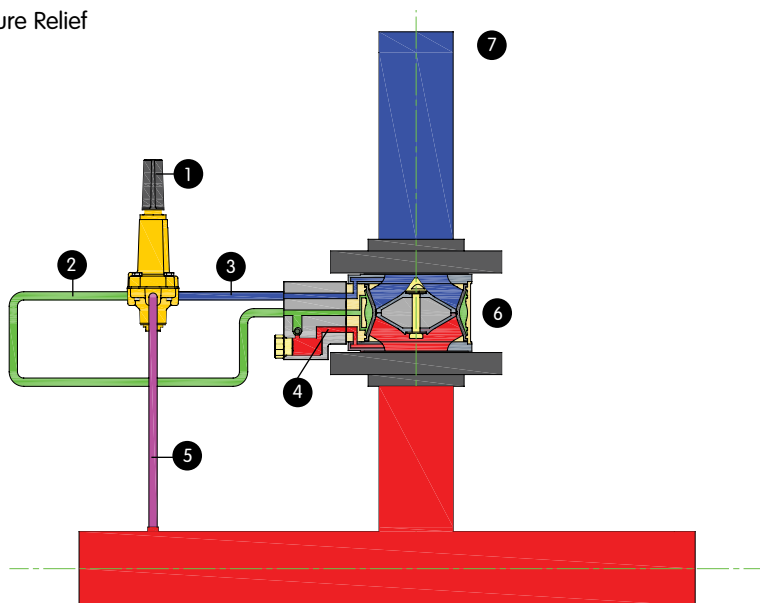

Pressure Relief

The pilot remains closed until the line pressure becomes higher than the set pressure of the pilot. The pilot opens and allows flow through the downstream bleed reducing the control pressure on the outside of the sleeve. Line pressure is now greater than the control pressure resulting in the Axial Flow Valve opening and releasing the excess line pressure to atmosphere.

Two Stage Pressure Reduction

Any application requiring a pressure drop greater than the maximum differential rating across a single Axial Flow Valve can be accomplished through a two stage pressure reduction. The first stage reduces the outlet pressure to an acceptable intermediate pressure. Then the second stage reduces to the final desired outlet pressure. This allows both Axial Flow Valves to be sized within their maximum differential ratings. The outlet pressure can even be reduced to inches W.C. if necessary.

Two Stage Pressure Reduction

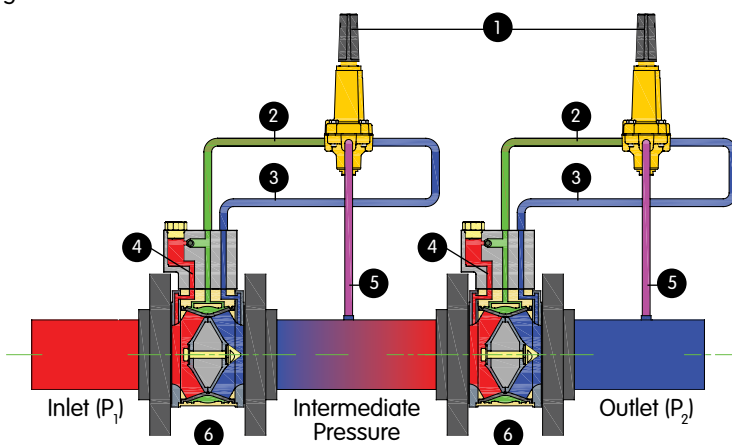

- 1 Pilot Regulator
- 2 Control Pressure
- 3 Downstream Bleed
- 4 Inlet Pressure
- 5 Sense Line
- 6 Axial Flow Valve
- 7 Relief Vent
- 8 Needle Valve
- 9 Inlet Supply
- 10 Plug
- 11 Pilot Regulator (Override)

Assembly Positions

Underpressure Shutoff

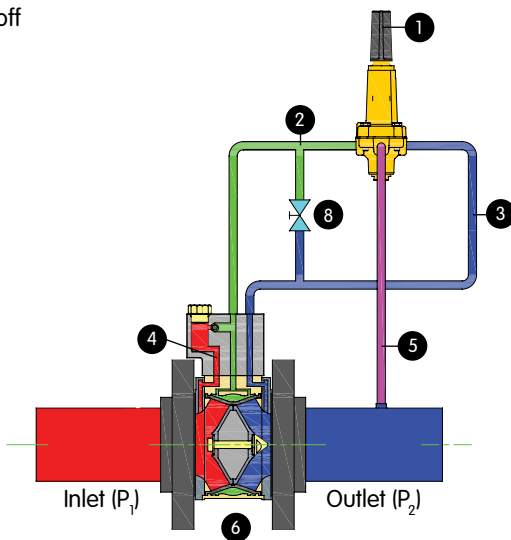

Underpressure Shutoff

Protecting a system from an upstream disruption may require the use of an underpressure shutoff. As long as the downstream pressure is above the set pressure, the pilot remains open. This results in flow through the downstream bleed reducing the control pressure on the outside of the sleeve. Since the Inlet pressure is greater than the control pressure, the Axial Flow Valve remains fully open. If the downstream pressure decreases below the set pressure, the pilot closes, and the inlet and control pressure equalize and close the Axial Flow Valve. The needle valve is used to reset the system. Opening the needle valve allows flow through downstream bleed (pilot bypass) reducing the control pressure on the outside of the sleeve. Inlet pressure is now much greater than the control pressure and the Axial Flow Valve fully opens. Once the downstream is pressurized, close the needle valve.

Worker/Monitor

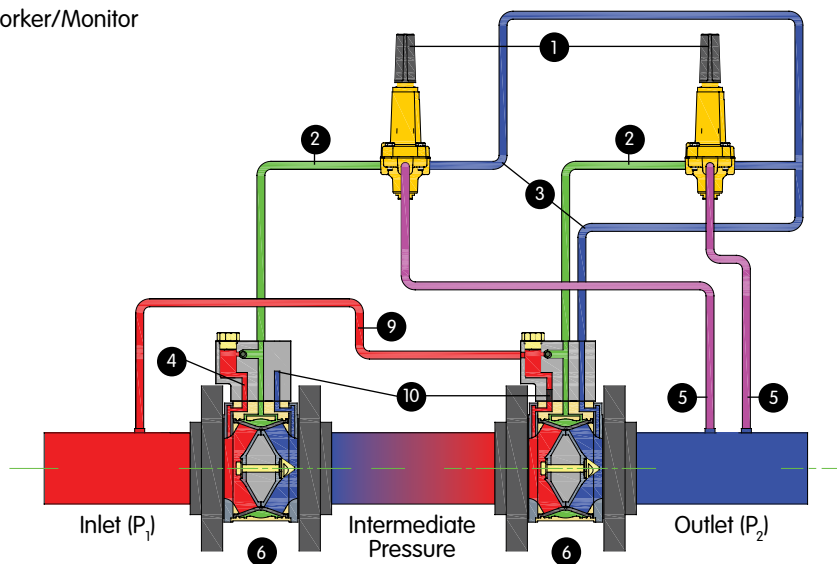

Worker/Monitor

During normal operation, a single Axial Flow Valve (the worker) is responsible for the pressure reduction. Another Axial Flow Valve (the monitor) is installed in series either upstream or downstream of the "worker". The monitor is set at a pressure slightly higher than the worker and is always fully open. If a malfunction occurs with the worker, the outlet pressure will increase to the monitor's set pressure and the monitor will assume control. The roles of the worker and monitor can be reversed by simply resetting their pilot's set pressure.

Two Stage Pressure Reduction with Monitor Override

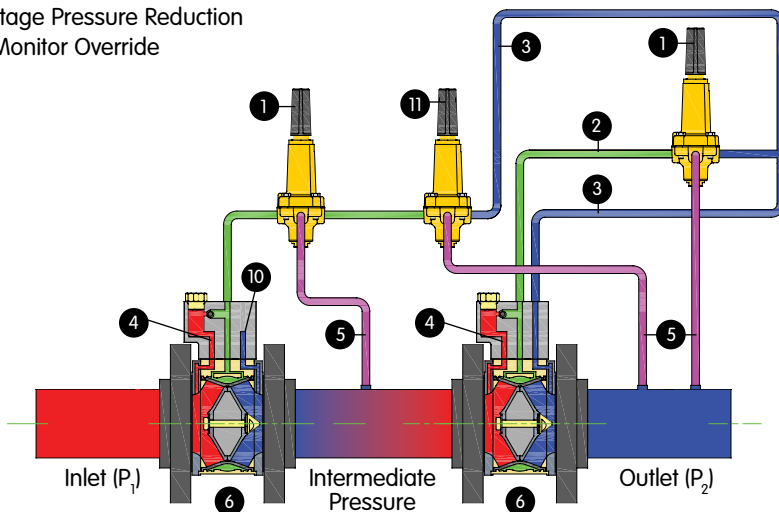

Two Stage Pressure Reduction with Monitor Override

Two Axial Flow Valves are used to perform the pressure reduction. However, the Axial Flow Valves need to be sized so that either one can handle the entire pressure drop. If a malfunction occurs in the first stage, the second stage will be able to handle the entire pressure drop. If the second stage malfunctions, downstream pressure will increase until it becomes higher than the set pressure of the override pilot. The override pilot assumes control of the first stage and is able to handle the entire pressure drop.