

# High Pressure Safety Shutoff Valve 2" ANSI Flange

HPSV 10020/604

**DUNGS®**  
Combustion Controls



**Normally closed automatic safety shutoff valve with the following approvals.**

#### CSA Certified

- ANSI Z21.21 • CSA 6.5
- Marked C/I
- File # 1010989
- Up to 100 PSI

#### CSA Certified

- CGA 3.9
- File # 1010989
- Up to 100 PSI

#### Codes and Standards

This product is intended for installations covered by but not limited to NFPA 37, UL 2200, CSA B149.1, CSA B149.3 or CSA B149.6.

**DUNGS is an ISO 9001 manufacturing facility.**

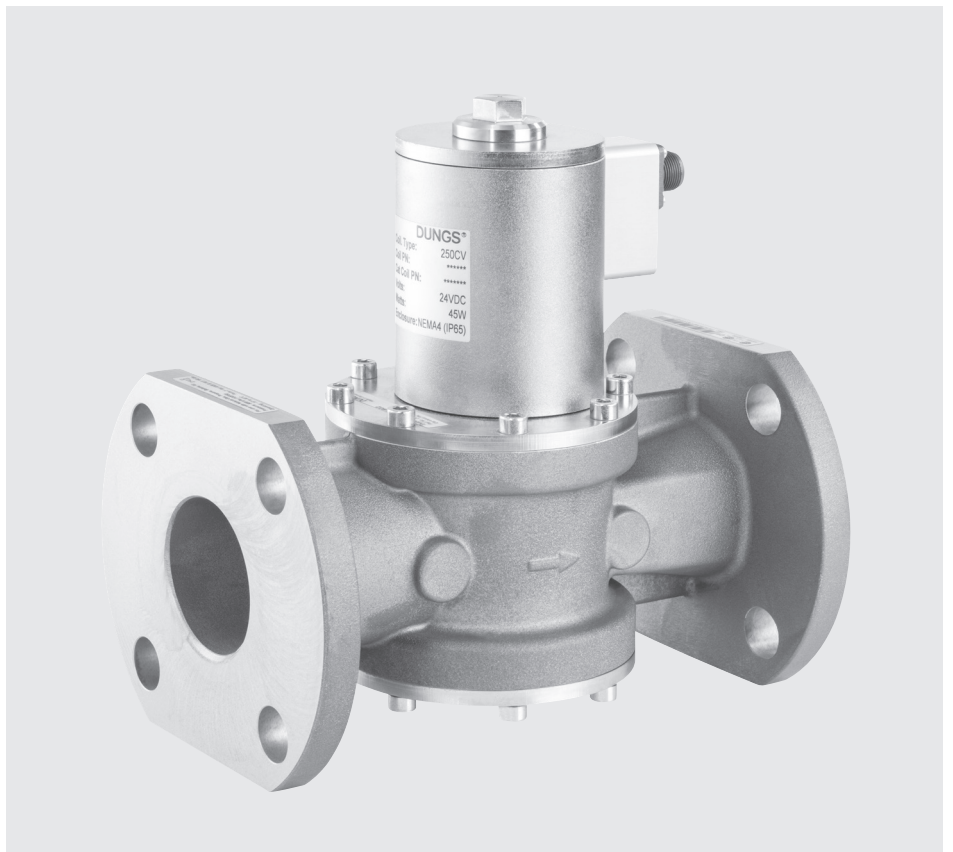

#### Technical Description

The HPSV high pressure safety shutoff valve is a single-stage automatic shutoff valve for gas engines or other high pressure applications using 24 VDC.

- Double-seated valve
- Max. operating pressure up to 100 PSI (7 bar)
- HPSV: fast-open/fast-close
- ANSI B16.5, Class 150, 2" flat face flange
- High flow rates

#### Application

The HPSV is recommended for industrial and commercial applications using spark ignited gas engines for standby and prime power generation.

The HPSV is suitable for dry natural gas, propane, butane, air and inert gases for pressures up to 100 PSI. Suitable for up to 0.1% by volume, dry H<sub>2</sub>S.

A "dry" gas has a dew point lower than +15 °F and its relative humidity is less than 60 %.

**HPSV 10020/604** Single-stage automatic shutoff valve, fast-open, fast-closing.**Specifications**

Flange Type Size	ANSI B16.5, Class 150 flat face 2"
Max. operating pressure	100 PSI (7 bar) acc. CGA 3.9 100 PSI (7 bar) acc. ANSI Z21.21/CSA 6.5 C/I
Max. body pressure	500 PSI (33 bar)
Max. close off pressure	100 PSI (7 bar)
Electrical ratings (-10 % to +15 %)	24 VDC
Power ratings	45 W
Enclosure ratings	NEMA Type 4 and Suitable for hazardous locations Class I, Division 2, Groups C and D, Temperature code T4A.
Electrical connection	Quick disconnect according to MIL ACS02A-10SL-04P-003 According to CSA C22.1 Part 1; leads are non-polarity sensitive
Operating time	100 % duty cycle
Closing time	< 1 s
Opening time (to max. flow)	< 1 s
Materials in contact with gas	Housing: Aluminium, Steel; free of non-ferrous metals Sealings on valve seats: NBR-based rubber
Ambient / Fluid Service Temperature	CSA -20 °F to +140 °F -29 °C to +60 °C Factory +5 °F to +140 °F -15 °C to +60 °C
Storage temperature	-40 °F to +185 °F (-40 °C to +85 °C)
Installation position	Safety shutoff valve from vertically upright to horizontal
Vibration Resistance	According to MIL 810 Vibration Profile
Gas strainer (standard)	Installed in the housing upstream 1 mm stainless steel mesh strainer

**Dimensions inch (mm)**

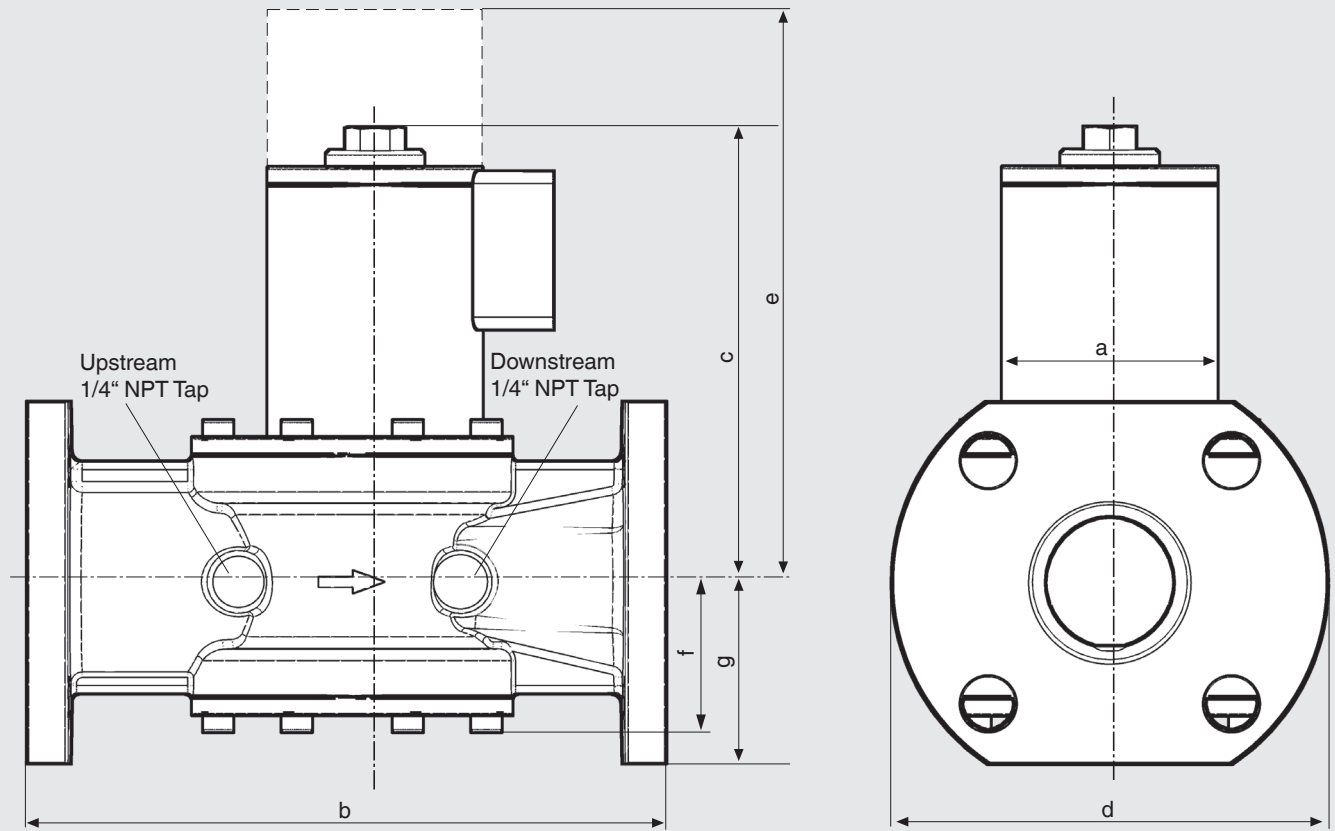

d = Space required for replacing solenoid

Type	Order No.	Dimensions [inch]							Weight [lbs]
		Dimensions [mm]							
		a	b	c	d	e	f	g	
HPSV 10020/604	270890	2.95	8.82	6.30	6.02	9.84	2.09	2.52	13.2
		75	224	160	153	250	53	64	6,0

# Flow Curve

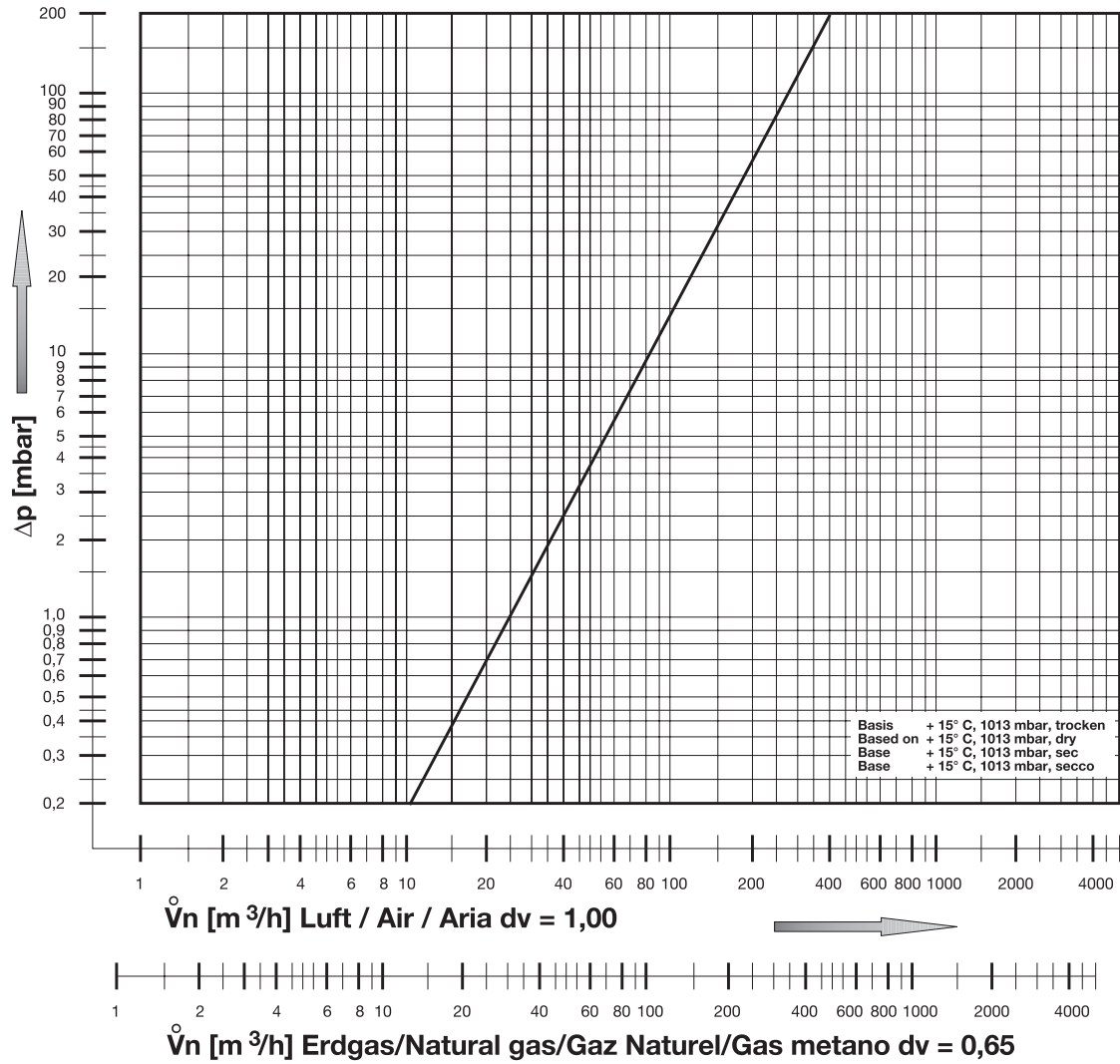

## Pressure drop for other gases

To determine the pressure drop when using a gas other than natural gas, use the flow formula below and f value located in the table below to determine

the “corrected” flow rate in CFH through the valve for the other gas used. For example, when using propane, divide the volume (CFH) of propane required for the application by the calculated value

f (f = 0.66 for propane). Use this “corrected” flow rate and the flow curve on the next page to determine pressure drop for propane.

## Determining equivalent flow through valves using another gas

$$\dot{V}_{\text{gas used}} = \dot{V}_{\text{Natural gas}} \times f$$

$$f = \frac{\text{Density of Natural gas}}{\text{Density of gas used}}$$

Type of gas	Density [kg/m <sup>3</sup> ]	s.g.	f
Natural gas	0.81	0.65	1.00
Butane	2.39	1.95	0.58
Propane	1.86	1.50	0.66
Air	1.24	1.00	0.80

