

Manually operated safety shut-off valve

HSAV
HSAV/5

DUNGS[®]
Combustion Controls

6.23



Technical description

The DUNGS manual operated shut-off valve HSAV, HSAV/5 is semi-automatic as per EN 161 for gas burners and gas appliances.

- Max. operating pressure: 500 mbar / 50 kPa (HSAV/5) or 1.5 bar / 150 kPa (HSAV)
- Class A, Group 2 as per EN 161
- normally closed
- Fast closing
- manual opening only when operating voltage applied
- DC solenoid, rectifier wiring with radio interference suppression in terminal box
- Mountable closed position signal contact to monitor closed position of valve
- Tube thread as per ISO 7/1
- Flange connection as per DIN EN 1092-1
- Reliable function, rugged and maintenance-free

Application

The DUNGS manual operated shut-off valve HSAV... is suitable for gases of families 1, 2, 3 and other neutral gaseous media. The manual operation shut-off valve is used for shut-off and release of gas supply to gas burners and gas appliances. The shut-off valve can only be opened manually when the operating voltage is applied.

Approval

EC type testing certificate as per:
• EC-Gas Appliances Regulation

Approvals in other important gas consuming countries.

HSAV	Single-stage solenoid valve, normally closed. Manually opening with operating voltage applied, fast closing.
HSAV/5	Single-stage solenoid valve, normally closed. Manually opening with operating voltage applied, fast closing. Closed position signal contact mountable.

Specifications

Nominal diameters	DN	65	80	100	
Pipe thread as per ISO /71	Rp	3/4	1	1 1/2	2
Flange	Connection flange (PN 16) as per DIN EN 1092-1				
Max. operating pressure	HSAV/5: 500 mbar (50 kPa), HSAV: 1.5 bar (150 kPa)				
Solenoid valve	Valve as per EN 161, Class A, Group 2				
Closing time	< 1 sec				
Opening	Manual, when operating voltage applied				
Materials of gas-conveying parts	Housing:	aluminium, steel, brass			
	Seals:	NBR basis			
Ambient temperature	-15°C to +60°C				
Installation position	Solenoid from vertically upright to horizontally lying - refer to operating and mounting instructions				
Dirt trap	Sieve installed, mesh width 1 mm				
Measuring/ignition gas connection	G 1/4 ISO 118, on both sides in inlet section, additionally G 3/4 on inlet side, from size DN 65 (flange) upwards				
Voltage/frequency	50-60 Hz, 230 V AC, -10% +15%, further voltages on request				
Rating / power consumption	See type overview				
Switch-on duration	100 %				
Degree of protection	IP 54, IP 65 on request				
Electrical connection	At screw terminals via PG 11 cable entry Plug connection as per DIN EN 175 301-803, can be retrofitted				
Closed position signal contact	Type K01/1 (DIN-tested), mountable on HSAV 5.../5				
Accessories	K01 closed position signal contact, see Datasheet 12.01				211 202
	Equipment plug for line socket as per DIN EN 175 301-803				215 733

Dimensions

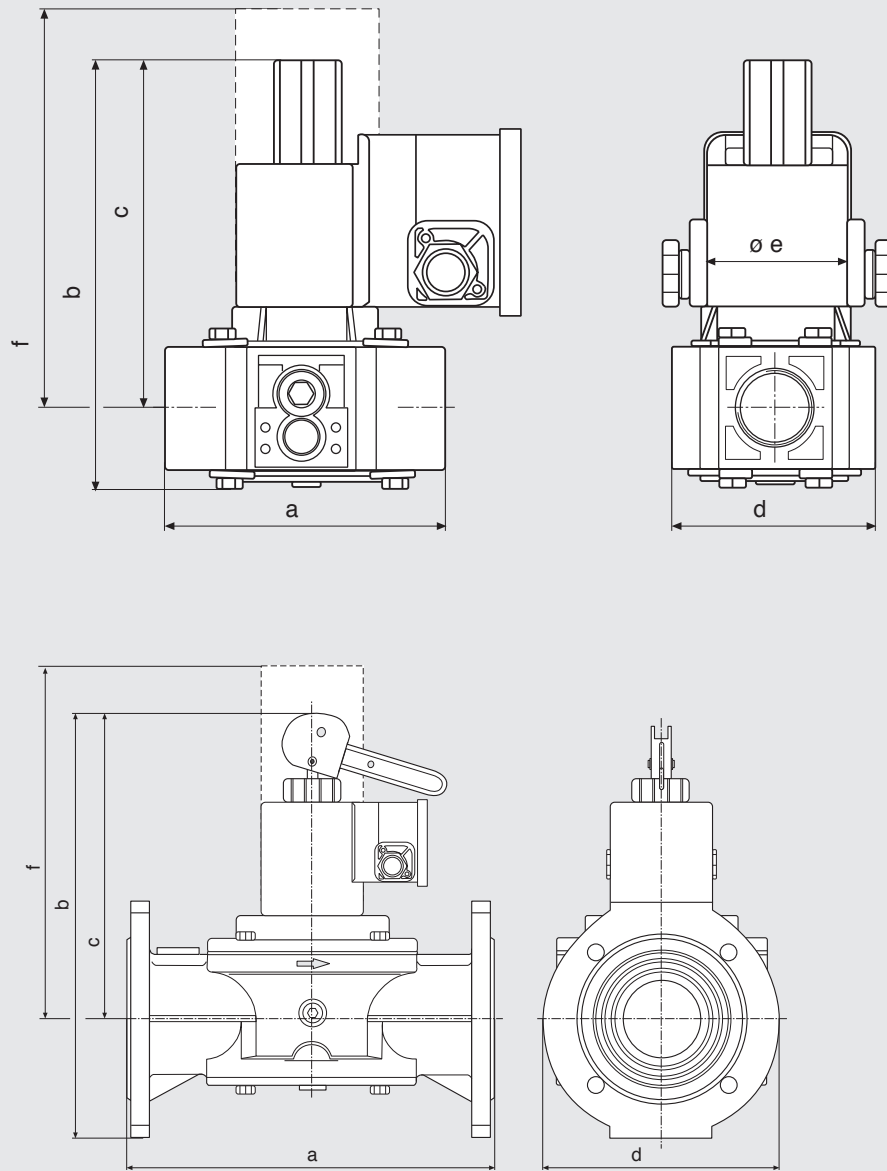

Type	DN / Rp	Order No.	p _{max.} [mbar]	P _{max.} [VA]	I _{max.} ~(AC) 230 V	Opening time	Dimensions [mm]					Weight [kg]	
							a	b	c	d	e		f
HSAV 1507	Rp 3/4	195 090	1500	15	0.08	< 1 s	100	145	120	73	50	170	1.3
HSAV 510/5	Rp 1	151 440	500	6	0.03	< 1 s	110	150	120	85	50	170	1.5
HSAV 515/5	Rp 1 1/2	155 790	500	9	0.05	< 1 s	150	200	160	110	60	250	2.5
HSAV 520/5	Rp 2	155 800	500	10	0.06	< 1 s	170	210	165	125	75	270	3.5
HSAV 5065/5	DN 65	155 810	500	20	0.11	< 1 s	290	325	235	185	80	350	8.0
HSAV 5080/5	DN 80	155 820	500	35	0.16	< 1 s	310	330	245	200	95	360	11.4
HSAV 5100/5	DN 100	155 830	500	60	0.28	< 1 s	350	375	275	240	115	410	17.7

HSAV/5 sectional drawing

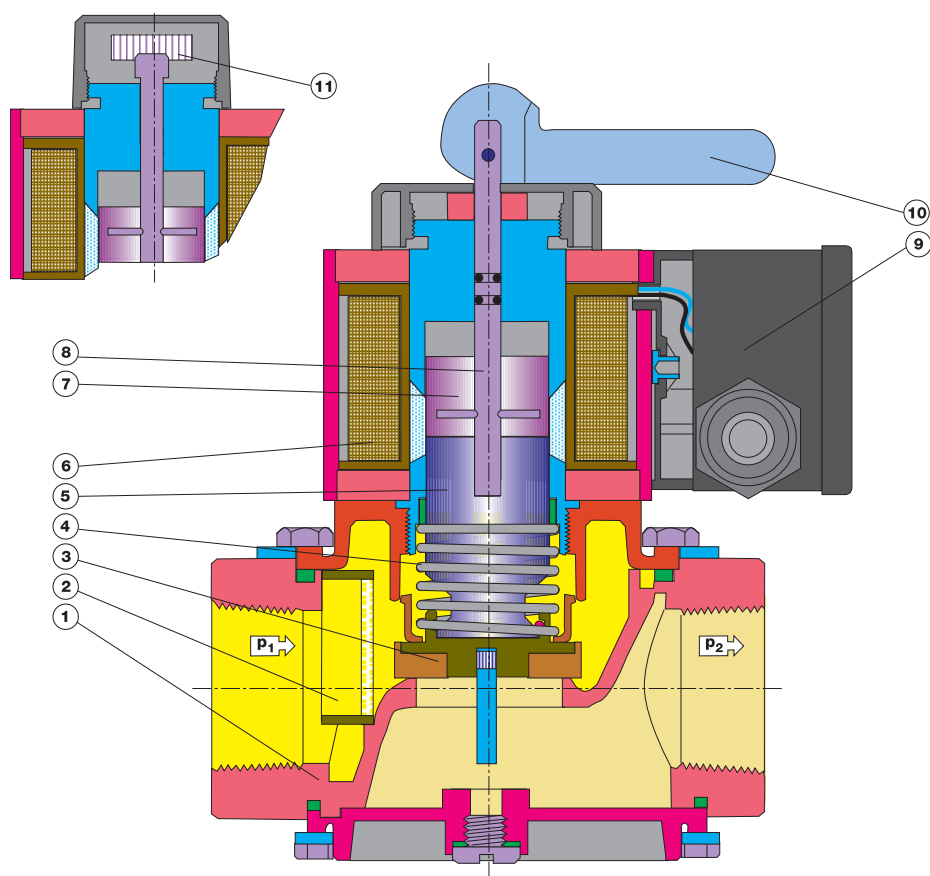

1	Housing	5	Armature	9	Electrical connection
2	Sieve	6	Solenoid coil	10	Lever
3	Valve plate	7	Auxiliary armature	11	Knurled screw: on 507, 510
4	Closing spring	8	Tension rod		

Technical description

The DUNGS manual operated shut-off valve is semi-automatic, operated with auxiliary power. The electromagnetic drive opens against the force of the closing spring 4 only with manual action.

If the auxiliary power is interrupted (operating voltage), closing spring 4 closes the valve within 1 second.

If gas supply is interrupted and auxiliary power is applied again, the shut-off valve does not open automatically.

The closing function cannot be impaired externally. The closed position of the valve can be monitored by a mountable closed position signal contact.

Setup
HSAV 1507, HSAV 510/5

1. Remove protection cap.
 2. Set knurled nut into closed position.
 3. Switch on voltage.
 4. Set knurled nut to open position by pulling.
- When voltage is applied, the HSAV remains open.**

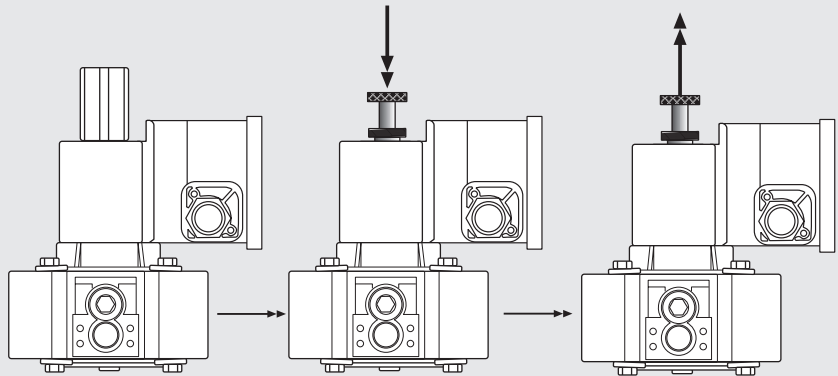

Setup
HSAV 515/5 - HSAV 520/5,
HSAV 5065/5 - HSAV 5100/5

1. Remove locking pin.
 2. Swivel lever through 180°.
 3. Apply voltage.
 4. Swivel lever through 180° again.
 5. Push locking pin through hole.
- When voltage is applied, the HSAV remains open.**

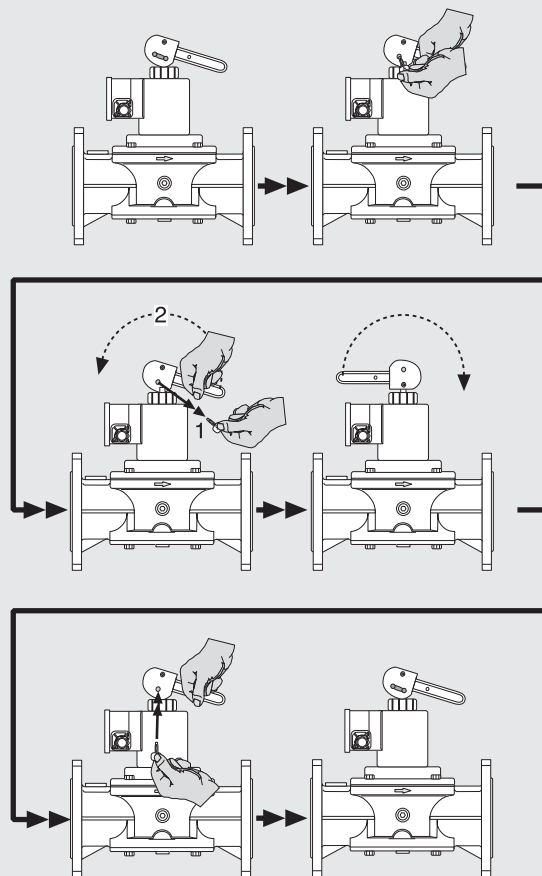

Manually operated
safety shut-off valve
HSAV
HSAV/5

Flow diagram

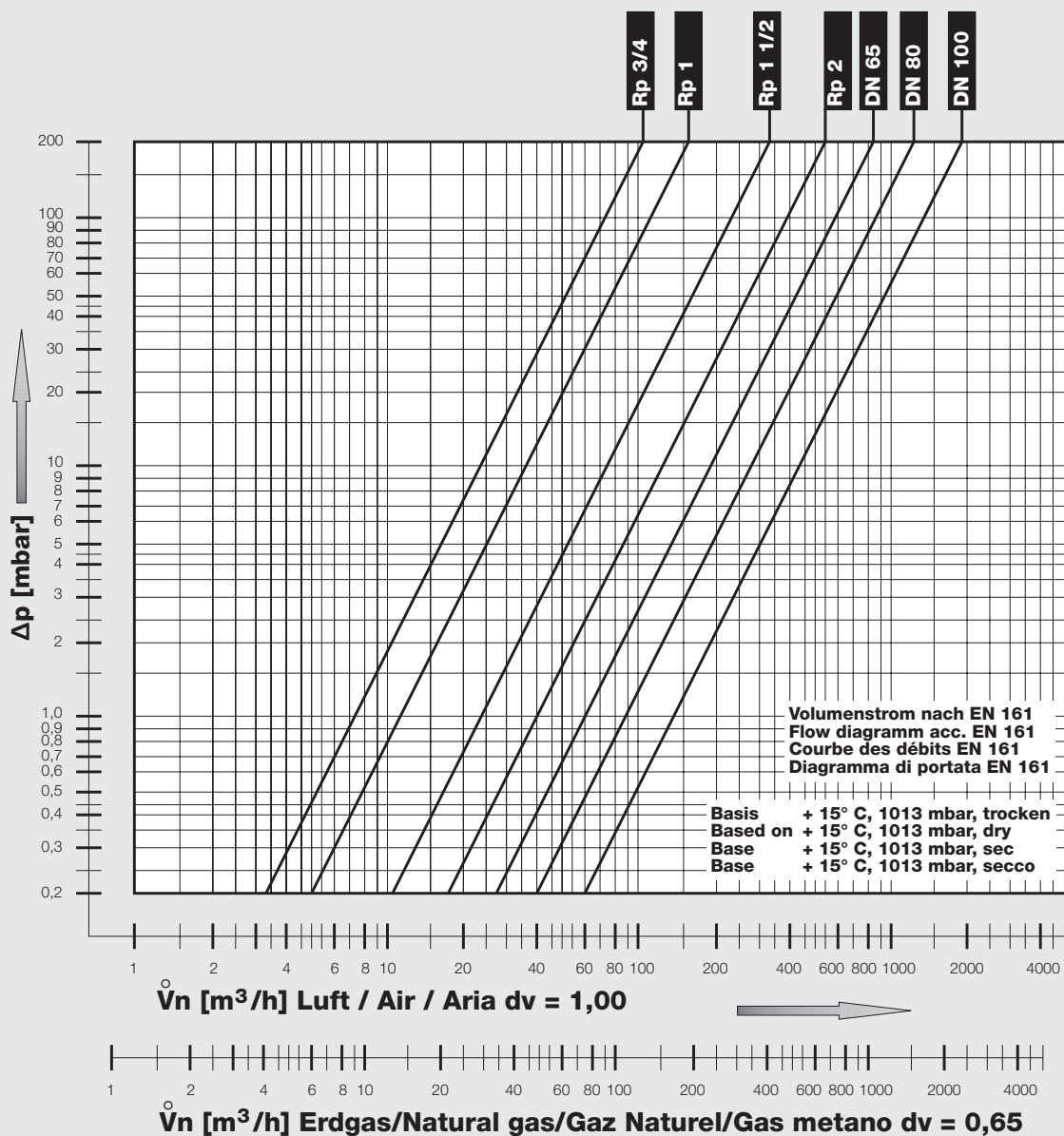

We reserve the right to make any changes in the interest of technical progress.