

Dual Modular Safety Shutoff Valves with Two-stage operation and Proof of Closure

DMV-ZRD/612 Series
DMV-ZRDLE/612 Series

DUNGS[®]
Combustion Controls



Two normally closed automatic shutoff valves in one housing. Valve 1 (V1) incorporates proof of closure. Each valve has the following approvals.

UL Recognized

- UL 429
- File #MH16727

CSA Certified

- ANSI Z21.21
- CSA 6.5
- Marked C/I
- File # 1010989

FM Approved

- Class 7411
- File # J.I. 3017969

Commonwealth of Massachusetts Approved Product

- Approval code G1-1107-35
- Gas Safety Shutoff Valve

US and Canadian Models

- DMV-ZRD 702/612 and 703/612
- DMV-ZRDLE 702/612 and 703/612

Codes and Standards

This product is intended for installations covered by but not limited to NFPA 86, ANSI Z83.4, ANSI Z83.18, ANSI Z21.13, UL 795, CSD-1, CSA B149.1 and CSA B149.3.

DUNGS is an ISO 9001 manufacturing facility.



Description

The Two-Stage Dual Modular Valve DMV-ZR/612 series combines two safety shutoff valves in one compact housing. Valve 2 incorporates two stages, which can be set at two different firing rates. Both firing rates are field adjustable and can modulate from high to low during burner operation.

Valve 1 (V1) of the DMV-ZRD and DMV-ZRDLE series is fast opening and fast closing. Valve 2 (V2) of the DMV-ZRD is fast opening, while V2 of the DMV-ZRDLE is slow-opening for smoother light-off. Max. flow adjustment on V2 provides variable main flow on both models.

Internal profiles and compact design optimize flow and provide a low pressure drop. Three body styles reduce inventory.

Directly mounting the following accessories creates a compact valve train without additional piping: pressure regulator, high and low gas pressure switches, valve proving system, and vent line adapter.

Application

The DMV-ZR is recommended for industrial and commercial heating applications, where two automatic shutoff valves, proof of closure and modulating between two firing rates during burner operation are required. The DMV-ZR Dual Modular Valve two stage is suitable for dry natural gas, propane, butane, air and inert gases.

A “dry” gas has a dew point lower than +15 °F and its relative humidity is less than 60 %.

DMV-ZRD/612 Two normally closed automatic shutoff valves in one housing. Valve 1 (V1) incorporates proof of closure. V1 and V2 are fast opening, fast closing. Adjustable max. flow with V2.

DMV-ZRDLE/612 Two normally closed automatic shutoff valves in one housing. Valve 1 (V1) incorporates proof of closure. V1 fast opening, fast closing. V2 is slow opening, fast closing. Adjustable max. flow and adjustable initial lift with V2.

Specifications

Body sizes	DMV 701/612	DMV 702/612	DMV 703/612
Pipe size / Thread	1/2" - 1" NPT	1" - 2" NPT	1" - 2" NPT
Max. operating pressure	7 PSI (500 mbar) FM, UL 5 PSI (360 mbar) CSA		
Max. body pressure	15 PSI (1000 mbar)		
Max. close off pressure	10 PSI (750 mbar)		
Electrical ratings (+10 % / -15 %)	110 - 120 VAC @ 50 - 60 Hz		
Power ratings	DMV 701: 70 VA	DMV 702: 85 VA	DMV 703: 115 VA
	Ratings shown are total power consumption for both valves inclusive. Inrush and full load current have the same VA rating.		
Enclosure rating	NEMA Type 12		
Electrical connection	DIN-connector with 1/2" NPT conduit adapter for valve 1 and valve 2, stage one. Screw terminals with 1/2" NPT conduit connection for valve 2, stage two. Use moisture-resistant No. 14 wire suitable for at least 194 °F (90°C)		
Operating time	100 % duty cycle		
Closing time	< 1 s		
Opening time (to max. flow)	DMV-ZRD	V1 & V2 < 1 s	
	DMV-ZRDLE	V1 < 1s; V2 adjustable to approx. 10 - 20 s at 70 °F	
Initial lift adjustment	Adjustable von V2		
Max. flow adjustment	DLE only; approx. 0 to 70 % of total flow Adjustable on V2, stage 1: approx. 5 to 30 % of stroke Adjustable on V2, stage 2: approx. 20 to 100 % of stroke		
Materials in contact with gas	Housing: Aluminium, Steel Sealings on valve seats: NBR-based rubber		
Ambient temperature rating	-20 °F to +150 °F (-30 °C to +65 °C)		
Installation position	Safety shutoff valve from vertically upright to horizontal		
Gas filter(optional)	Replaceable integral gas filter (50 micron) in inlet of DMV.		
Gas strainer (standard)	Installed in the housing upstream V1 (23 mesh)		
Proof of closure switch (factory mounted and calibrated on V1)	SPDT switch with position indication lamps; AC max. 10 A resistive @ 120 VAC and AC max. 8 A inductive @ 120 VAC		
Position indication (mechanical)	Visual indicator (VI), optional for valve #2		
Test ports / Pressure switch mounting ports	G 1/8 ISO 228 ports available on both sides. Each side has one port upstream V1, one between V1 and V2, one downstream V2 and one on each flange.		
Valve proving system (optional)	Model VPS 504 S06; mounts directly to either side of DMV.		

Electrical connection

Use moisture-resistant No. 14 wire suitable for at least 194 °F (90 °C)

DIN Connector screw terminal connections

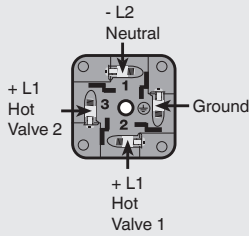

Valves V1 & V2 stage 1

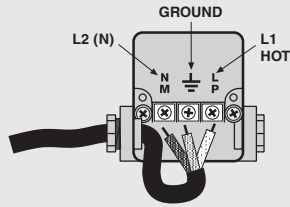

Valve V2 stage 2

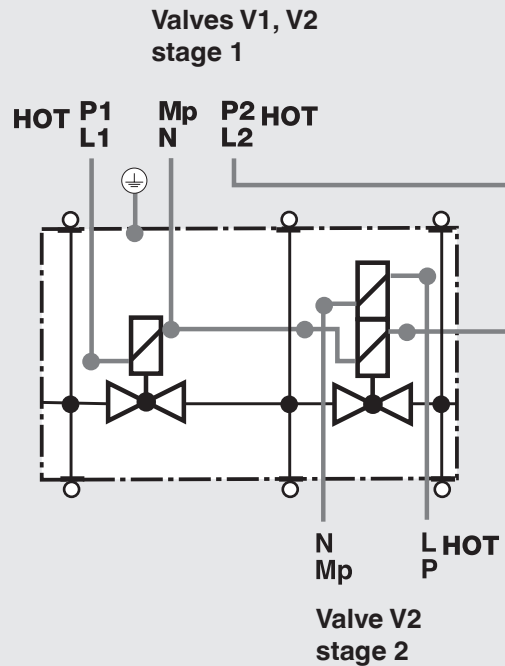

Valves V1, V2 stage 1

Valve V2 stage 2

Opening behavior DMV-ZRD(LE)

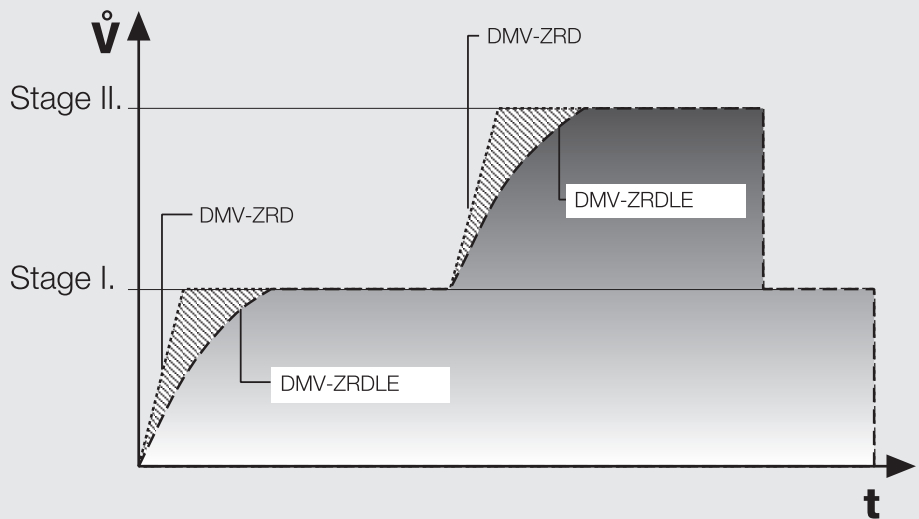

FRI Gas pressure regulator

Mounting the FRI series gas pressure regulator directly to the DMV dual safety shutoff valve is possible with a mounting kit.

The FRI pressure regulator can be installed upstream or downstream of the DMV dual safety shutoff valve depending on application requirements.

FRI mounting kit for DMV

FRI 705 - 707/6 to DMV 701
Order No. 219967

FRI 710-712/6 to DMV 702 + DMV 703
Order No. 219968

Optional Accessories

VPS 504

Valve proving system (approved by some authorities having jurisdiction in lieu of vent valve and "proof of closure" e.g. FM, IRI).

Integral gas filter

50 micron gas filter

Pre-Mount Filter

50 micron gas filter

GAO/GMH/GML A2

gas pressure switch

Position indication

Visual indicator (VI)

Vent Line Adapter

Factory installed vent line adapter which allows the routing of a normally open vent valve and a vent line connection between both safety shutoff valves.

Adapters

- 1/4" NPT adapter (225047)
- 1/2" NPT Pilot gas adapter; Check flow requirements. (225043)
- G 1/8" Test nipple (219008)
- Port 3 Pressure switch mounting adapter (273777)

Dimensions inch (mm)

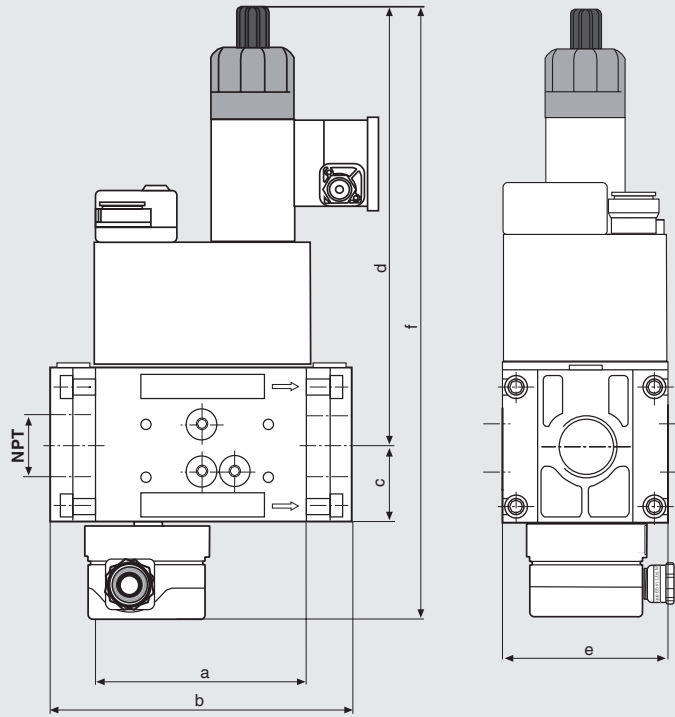

Type	110 - 120 VAC @ 50 - 60 Hz Order No.	Power* [VA]	Dimensions [inch] Dimensions [mm]						Weight [lbs] [kg]
			a	b***	c**	d	e	f	
DMV-ZRD 701/612	267094	70	3.7 93	5.6 141	1.4 35	7.5 190	2.9 73	11.5 292	6.6 3,0
DMV-ZRD 702/612	267096	120	4.9 124	6.9/7.9 174/201	1.8 45	10.0 255	3.9 101	14.4 366	14.3 6,5
DMV-ZRD 703/612	267099	135	4.9 124	6.9/7.9 174/201	1.8 45	11.0 280	3.9 101	15.4 391	18.0 8,2
DMV-ZRDLE 701/612	267095	70	3.7 93	5.6 141	1.4 35	8.5 215	2.9 73	12.5 318	6.8 3,1
DMV-ZRDLE 702/612	267098	120	4.9 124	6.9/7.9 174/201	1.8 45	10.6 270	3.9 101	15.0 381	14.5 6,6
DMV-ZRDLE 703/612	267100	135	4.9 124	6.9/7.9 174/201	1.8 45	13.0 330	3.9 101	17.4 442	18.3 8,3

* Inrush current and full load current have the same VA rating.

** When using with the vent line adapter assembly, add 1.65" to dimension c. (see vent line adapter information sheet)

*** DMV 702/703 with 1" or 1 - 1/4" flange: 6.9" / DMV 702/703 with 1 - 1/2" or 2" flange: 7.9"

Valve Description	Flange	NPT	Rp
DMV-ZR 701	1/2"	222371	222341
DMV-ZR 701	3/4"	222368	222342
DMV-ZR 701	1"	221999	222001
DMV-ZR 702 & 703	1"	222369	222343
DMV-ZR 702 & 703	1 1/4"	222370	222344
DMV-ZR 702 & 703	1 1/2"	222003	221884
DMV-ZR 702 & 703	2"	221997	221926

DIN-Connector	210319
Visual indicator	266949

Integral Filter & Strainer	P/N
DMV-ZR 701	230440
DMV-ZR 702	230441
DMV-ZR 703	230441

 **DMV-ZRD(LE) 7.../612 flanges and other accessories are interchangeable**

 **Please order flanges, position indicators and gas filters separately**

Flow curve

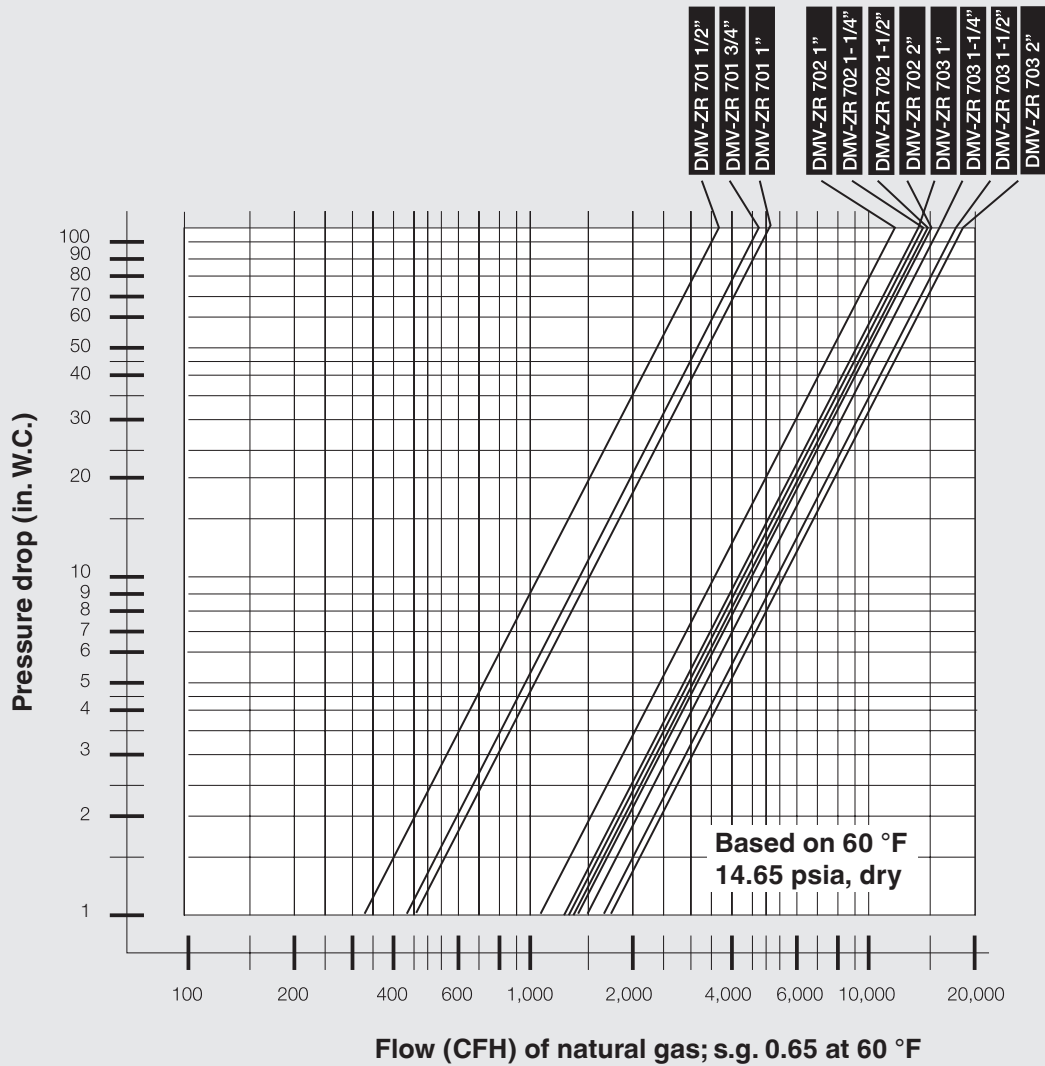

⚠ Size valve for at least 2 in. W.C. of pressure drop or more if the inlet pressure in the application is 1/2 in. W.C. or less. Otherwise, the difference in flow rate between stage 1 and stage 2 will be noticeable.

We reserve the right to make any changes in the interest of technical progress.

**Dual Modular Safety
Shutoff Valves with
Two-stage operation and
Proof of Closure**

**DMV-ZRD/612 Series
DMV-ZRDLE/612 Series**

DUNGS®
Combustion Controls

