

Dual Modular Safety Shutoff Valves with Proof of Closure and NEMA Type 4x Enclosure

DUNGS[®]
Combustion Controls

DMV-D 704/624
DMV-D 704/634
DMV-DLE 704/624
DMV-DLE 704/634



Two normally closed automatic shutoff valves in one housing. Valve 2 (V2) incorporates proof of closure on both /624 and /634 models. Valve 1 (V1) incorporates proof of closure on model /634 only. Each valve has the following approvals.

CSA Certified

- ANSI Z21.21/CSA 6.5
- Marked C/I
- File # 112901

Commonwealth of Massachusetts Approved Product

- Approval code G1-1107-35
- Gas Safety Shutoff Valve

US, Canadian and EU Models

- DMV-D 704/604
- DMV-DLE 704/604
- 2 in. NPT or 2 in. Rp

Codes and Standards

This product is intended for installations covered by but not limited to NFPA 85, NFPA 86, NFPA 37, NFPA 160, ANSI Z83.4/ CSA 3.7, ANSI Z83.18/CSA 4.9, ANSI Z21.13, CSD-1, CAN1-3.1, CGA 3.2, CSA 3.8, CSA B149.1 or CSA B149.3.

DUNGS is an ISO 9001 manufacturing facility.



Description

The Dual Modular Valve DMV/624 combines two automatic shutoff valves in one compact housing. Valve 2 incorporates proof of closure.

The DMV/634 combines two automatic shutoff valves in one compact housing. Valve 1 and Valve 2 incorporate proof of closure.

Valve 1 (V1) of the DMV-D and DMV-DLE series is fast opening and fast closing. Valve 2 (V2) of the DMV-D is fast opening, while V2 of the DMV-DLE is slow-opening for smoother light-off. Max. flow adjustment on V2 provides variable main flow on both models.

Internal profiles and compact design optimize flow and provide a low pressure drop.

Directly mounting the following accessories creates a compact valve train without additional piping: High and low gas pressure switches, Vent line adapter, DMK butterfly control valve, and VPS valve proving system.

Application

The DMV is recommended for industrial and commercial heating applications that require two safety shutoff valves with proof of closure.

The DMV Dual Modular Valve is suitable for natural gas, propane, butane, air and inert gases. The DMV is suitable for dry natural gas, propane, butane, air and inert gases.

A "dry" gas has a dew point lower than +15 °F and its relative humidity is less than 60 %.

DMV-D/624	Two normally closed automatic shutoff valves in one housing. Valve 2 (V2) incorporates proof of closure. V1 and V2 are fast opening, fast closing. Adjustable max. flow with V2.
DMV-DLE/624	Two normally closed automatic shutoff valves in one housing. Valve 2 (V2) incorporates proof of closure. V1 fast opening, fast closing. V2 is slow opening, fast closing. Adjustable max flow and adjustable initial lift with V2.
DMV-D/634	Two normally closed automatic shutoff valves in one housing. Both valves incorporate proof of closure. V1 and V2 are fast opening, fast closing. Adjustable max flow with V2.
DMV-DLE/634	Two normally closed automatic shutoff valves in one housing. Both valves incorporate proof of closure. V1 fast opening, fast closing. V2 is slow opening, fast closing. Adjustable max. flow and adjustable initial lift with V2.

Specifications

Body sizes	DMV-D(LE) 704/624; DMV-D(LE) 704/634	
Pipe size / Thread	2" NPT or Rp	
Max. operating pressure	7 PSI (500 mbar)	
Max. body pressure	15 PSI (1000 mbar)	
Max. close off pressure	10 PSI (750 mbar)	
Electrical ratings (+10 % / -15 %)	110 - 120 VAC @ 50 - 60 Hz	
Power rating	90 VA Ratings shown are total power consumption for both valves inclusive. Inrush and full load current have the same VA rating.	
Enclosure rating	NEMA Type 4x	
Electrical connection	Screw terminals with 1/2" NPT conduit connection	
Operating time	100 % duty cycle	
Closing time	< 1 s	
Opening time (to max. flow)	DMV-D series	V1 & V2 < 1 s
	DMV-DLE series	V1 < 1 s; V2 adjustable 10 to 20 s at 70 °F
Initial lift adjustment	Adjustable on V2	DLE only; 0 to 70 % of total flow; 0 to 35% of stroke
Max. flow adjustment	Adjustable on V2	<10 to 100 % of total flow; <10 to 100% of stroke
Materials in contact with gas	Housing: Aluminum & Steel, free of non-ferrous metals Sealings on valve seats: NBR-based rubber	
Ambient temperature rating	-20 °F to +140 °F (-30 °C to +60 °C)	
Installation position	Safety shut off valve from vertically upright to horizontal	
Gas strainer (standard)	Installed in the housing upstream V1 (23 mesh)	
Proof of closure switch Factory mounted and calibrated	SPDT switch with indication lamps;	AC max. 10A resistive @ 120 VAC AC max. 8 A inductive @ 120 VAC
Position indication (mechanical)	Visual indicator (VI), optional for valve #1 of DMV-D(LE) 704/624 ONLY	
Test ports / Pressure switch mounting ports	G 1/8 ISO 228 ports available on both sides. Each side has two ports upstream of V1, two between V1 and V2, one downstream V2 and one on each flange.	

DMV dual modular safety shutoff valve system

Optional mounting system shown,
other configurations possible

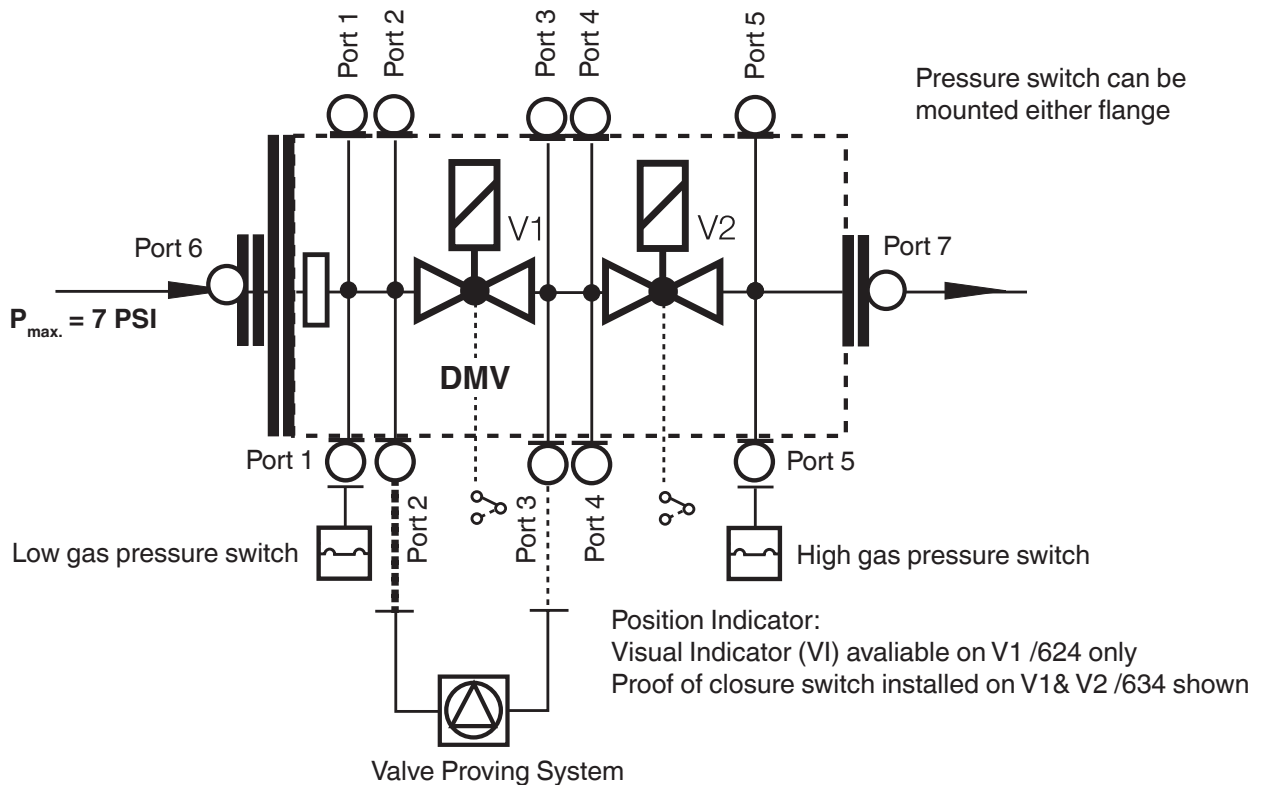

 When an accessory is added to the DMV, it may not be possible to mount other devices.

Additional Accessories

GAO/GMH/GML A2 pressure switch

Valve proving system

VPS504 S06 (only comes in NEMA Type 12 enclosure).

DMK butterfly control valve

Mounts directly downstream of DMV to modulate gas flow. Requires actuator. Use DMA actuator with DMK butterfly valve. NEMA Type 4 enclosure available.

Adapters

- 1/4" NPT adapter (225047)
- 1/2" NPT Pilot gas adapter; Check flow requirements. (225043)
- G 1/8" Test nipple (219008)
- 1" NPT Vent line adapter (243760)

**Dimensions inch (mm)
DMV-DLE 704/634 shown**

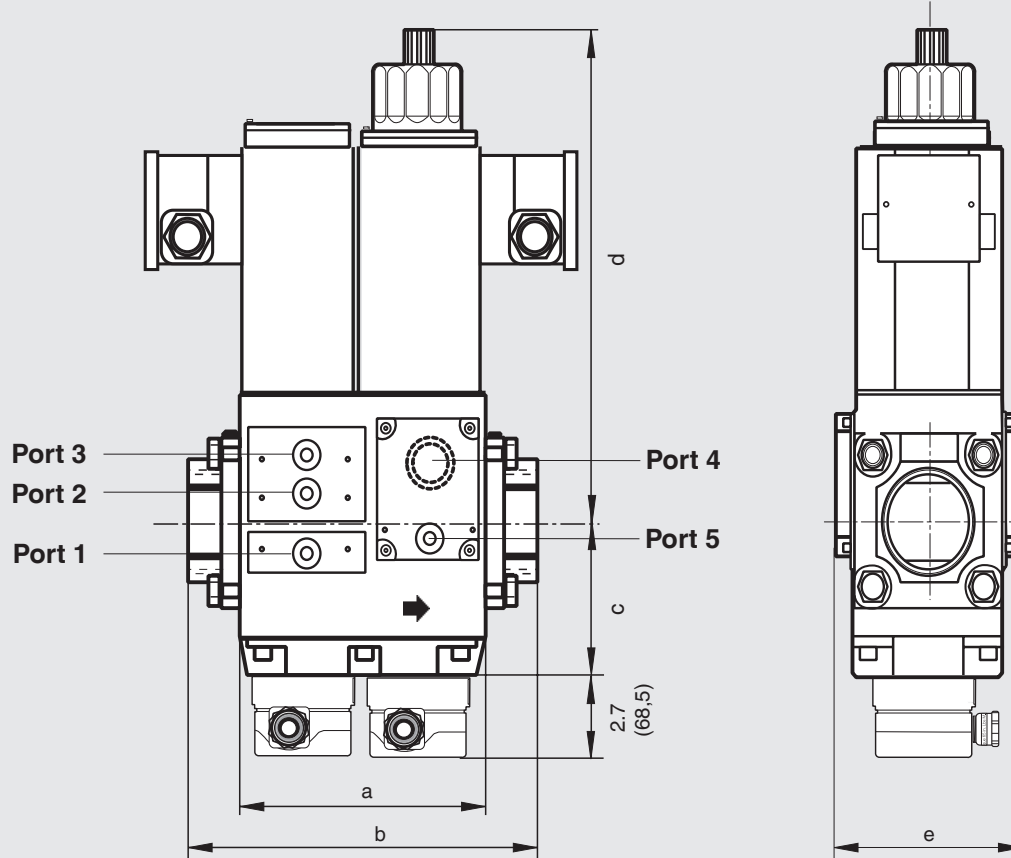

Type	Proof of closure	110 - 120 VAC @ 50 - 60 Hz Order No.	Power* [VA]	Dimensions [inch] Dimensions [mm]					Weight [lbs] [kg]
				a	b	c	d	e	
DMV-D 704/624	Valve 2	267051	90	6.4 162	9.4 239	3.5 88	9.1 231	5.0 127	26.6 12,1
DMV-DLE 704/624	Valve 2	267053	90	6.4 162	9.4 239	3.5 88	9.7 245	5.0 127	27.0 12,3
DMV-D 704/634	Valve 1 & 2	267052	90	6.4 162	9.4 239	3.5 88	9.1 231	5.0 127	27.5 12,5
DMV-DLE 704/634	Valve 1 & 2	267054	90	6.4 162	9.4 239	3.5 88	9.7 245	5.0 127	27.9 12,7

* Inrush current and full load current have the same VA rating.

Valve Description	Flange	NPT	Rp
DMV-D(LE) 704/624	2"	232407	215384
DMV-D(LE) 704/634	2"	232407	215384

Accessories/Adapters	P/N
CPI 400 Interlock switch	266968
Visual indicator (mechanical valve position indicator)	266949
Vent Line Adapter (field mountable)	243760

⚠ Please order flanges, position indicators and gas filters separately

DMV-D(LE) 704/634
sectional drawing

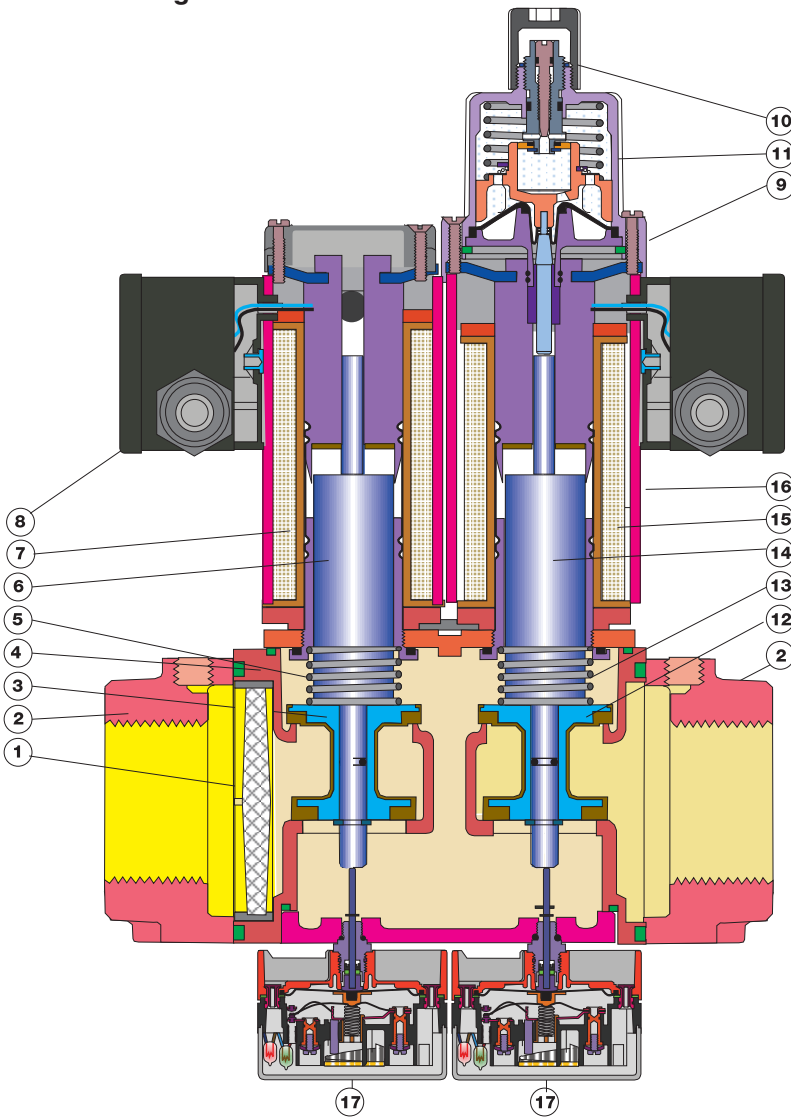

- 1 Strainer
- 2 Flange
- 3 Valve V1
- 4 Housing
- 5 Closing spring V1
- 6 Plunger V1
- 7 Solenoid V1
- 8 Electrical connection
- 9 Max flow adjustment
- 10 Initial lift adjustment (DMV-DLE)
- 11 Hydraulic brake (DMV-DLE)
- 12 Valve V2
- 13 Closing spring V2
- 14 Plunger V2
- 15 Solenoid V2
- 16 Solenoid housing
- 17 Proof of closure switch

Pressure drop for other gases

To determine the pressure drop when using a gas other than natural gas, use the flow formula below and f value located in the table below to determine

the “corrected” flow rate in CFH through the valve for the other gas used. For example, when using propane, divide the volume (CFH) of propane required for the application by the calculated value

f (f = 0.66 for propane). Use this “corrected” flow rate and the flow curve on the next page to determine pressure drop for propane.

Determining equivalent flow through valves using another gas

$$\dot{V}_{\text{gas used}} = \dot{V}_{\text{Natural gas}} \times f$$

$$f = \sqrt{\frac{\text{Density of Natural gas}}{\text{Density of gas used}}}$$

Type of gas	Density [kg/m ³]	s.g.	f
Natural gas	0.81	0.65	1.00
Butane	2.39	1.95	0.58
Propane	1.86	1.50	0.66
Air	1.24	1.00	0.80

**Dual Modular Safety
Shutoff Valves with
Proof of Closure and
NEMA Type 4x Enclosure**

**DMV-D 704/624
DMV-D 704/634
DMV-DLE 704/624
DMV-DLE 704/634**



Flow curve

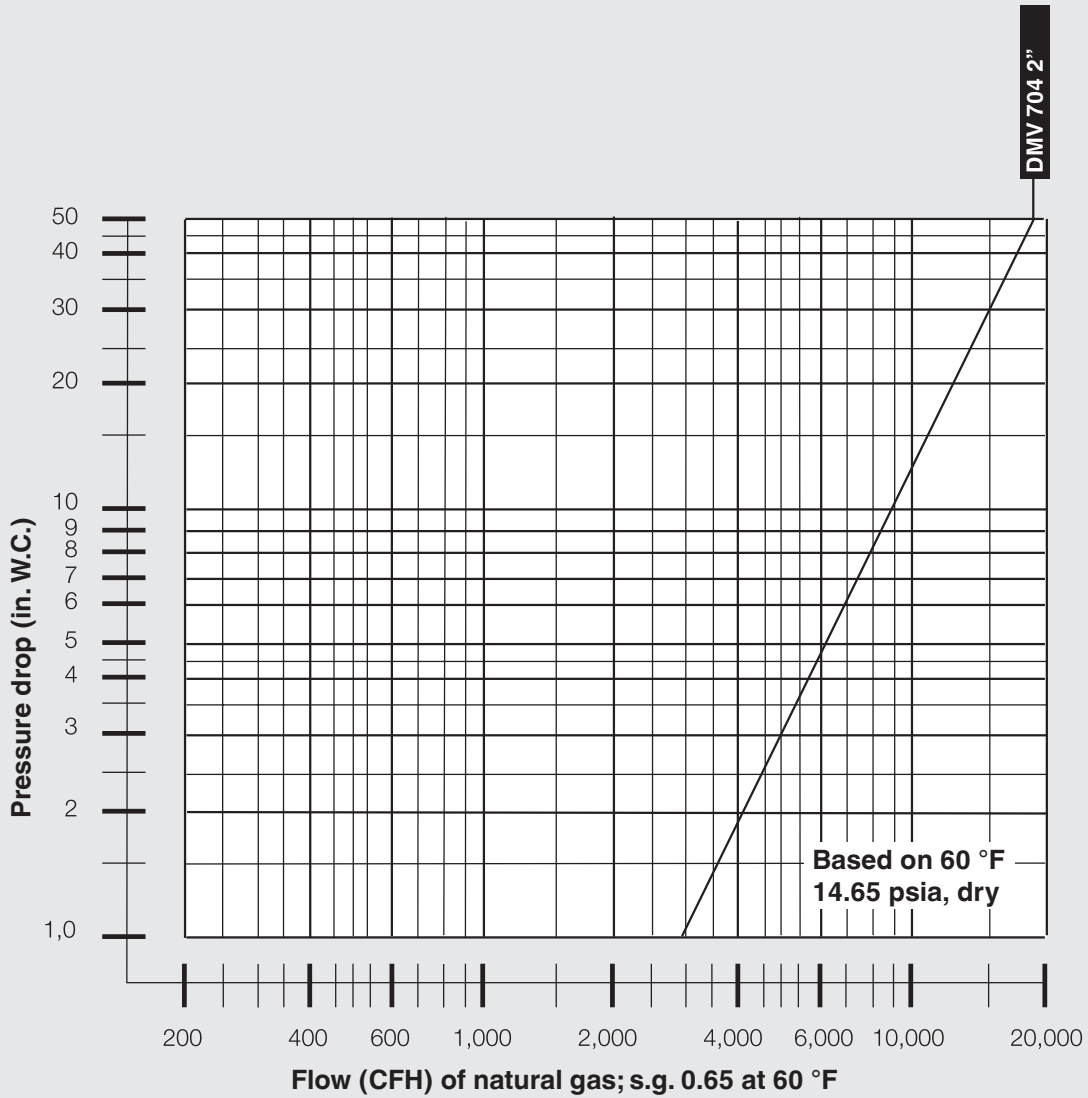

We reserve the right to make any changes in the interest of technical progress.

