

# LVG SERIES

Gas Limiting Orifice Valve



## Features

- Precision machined valve flow piston
- Rugged cast iron body
- Replaceable cartridge assembly for LVG 5 05-5 20
- Straight through valve design; right angle valve option
- Pressure rated to 25 psig (172 kPa)

## Benefits

- Fine flow adjustment
- Maintenance free operation
- Vibration proof flow setting



The Hauck LVG Series Limiting Orifice Gas Valves are designed to allow precise setting of high fire gas flow. They are used for single or multiple burner systems. The standard LVG series valves can be used as straight through type valves, and angle type valves are available to meet burner piping system requirements. These valves are designed for use with any commercial fuel gas; coke oven gas versions are also available.

There are nine LVG valve sizes from 1/2 NPT to 4" ANSI flange. Valves with metric connections are also available. Capacities for natural gas range from 760 to 24,640 scfh (20 to 660 nm<sup>3</sup>/hr) at a pressure drop of 6.9" wc (1,720 Pa).

## HAUCK MANUFACTURING COMPANY

P.O. Box 90  
Lebanon, PA 17042  
Phone: 717-273-0064  
Fax: 717-273-0882  
[www.hauckburner.com](http://www.hauckburner.com)

Combustion Excellence Since 1888

# LVG SERIES

GAS LIMITING ORIFICE VALVE



## ADVANTAGES OF THE LVG SERIES

### Precise Flow Adjustment

### Maintenance Free Operation

### Vibration Proof Flow Setting

LVG series valves are designed for use as straight through type valves to set high fire on single or multiple burner systems. Angle type valves are available to meet burner piping system requirements. Valves are also available with metric connections or for coke oven gas.

Installation should be made as close to the burner as possible to minimize burner response time to changes in gas flow, and downstream of a shutoff valve. Though the valves are designed to provide minimal leakage flow when fully closed, they **can not** be used as shutoff valves.

Precise adjustment is accomplished by rotating the adjusting screw to increase or decrease the gas flow through the valve. After the valve is properly adjusted, the hex screw cap should be replaced to protect the setting. The seal design of the cartridge stem permits operating pressures up to 25 psig (172 kPa).

[www.hauckburner.com](http://www.hauckburner.com)

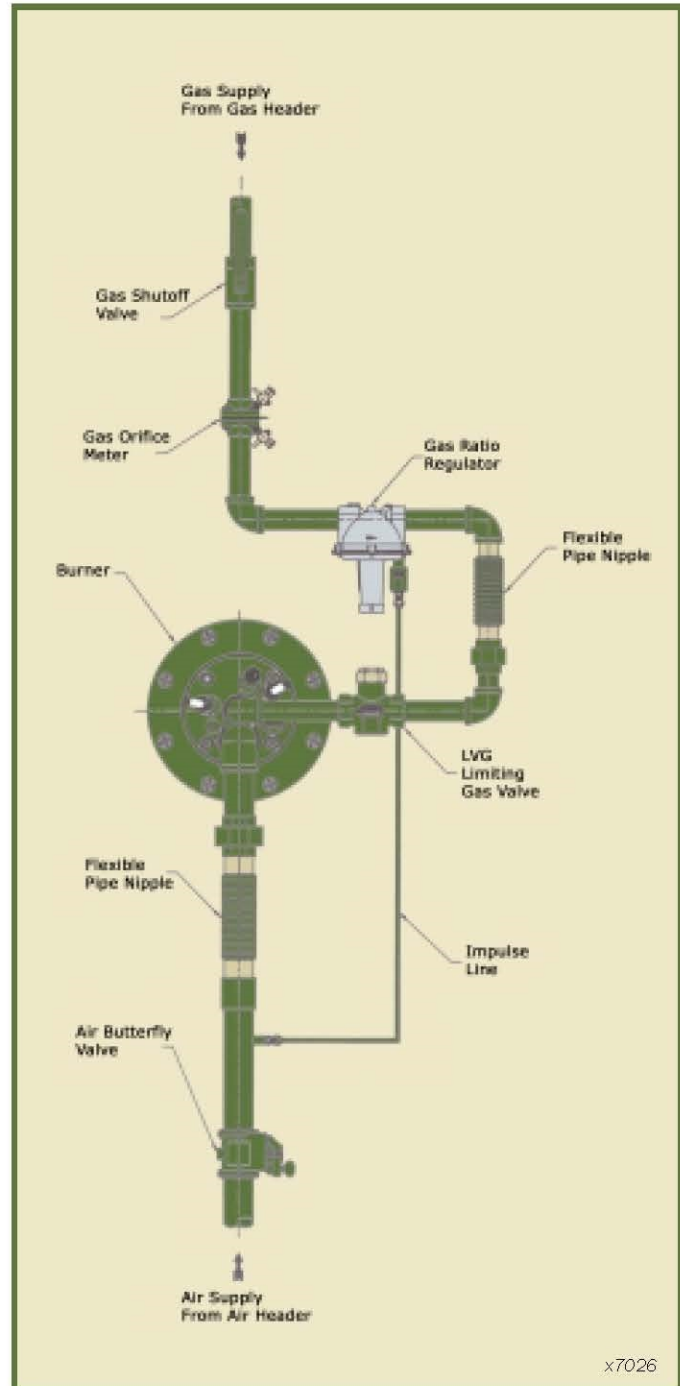

Typical LVG Valve Location  
in Burner Ratio Control System



## CAPACITIES

# GAS LIMITING ORIFICE VALVES LVG SERIES

NATURAL GAS  
Full Open Valve Capacity (scfh)

Model No.	Pipe Size	PRESSURE DROP						
		1"wc	2"wc	4"wc	6.9"wc	13.8"wc	20.8"wc	27.7"wc
LVG 505D	1/2 NPT	275	410	575	757	1,055	1,290	1,470
LVG 507D	3/4 NPT	405	590	815	1,070	1,520	1,855	2,120
LVG 510C	1 NPT	635	870	1,230	1,625	2,245	2,750	3,155
LVG 512C	1-1/4 NPT	1,070	1,520	2,160	2,840	4,020	4,890	5,630
LVG 515C	1-1/2 NPT	1,500	2,140	3,000	3,930	5,560	6,740	7,680
LVG 520C	2 NPT	2,560	3,520	5,010	6,565	9,080	11,120	12,700
LVG 525A	2-1/2 NPT	3,985	5,630	7,970	10,480	14,830	18,160	20,960
LVG 530A	3 NPT	5,215	7,830	14,330	13,720	19,420	23,770	27,440
LVG 540A	4"FLG	9,370	13,240	18,740	24,640	34,880	42,700	49,270

Notes:

1. Capacities based on natural gas @ 0.60 s.g. and 60°F fluid temperature.
2. Pressure drop measured across full open valve.
3. Maximum inlet pressure is 25 psig.
4. For natural gas leakage rates with fully closed valve, consult Hauck.

## METRIC CAPACITIES

NATURAL GAS  
Full Open Valve Capacity (nm<sup>3</sup>/hr)

Model No.	Pipe Size	PRESSURE DROP						
		249 Pa	498 Pa	995 Pa	1,720 Pa	3,430 Pa	5,180 Pa	6,900 Pa
LVG 505D-E	1/2 RP	7.4	11.0	15.4	20.3	28.3	34.6	39.4
LVG 507D-E	3/4 RP	10.8	15.8	21.8	28.7	40.7	49.7	56.8
LVG 510C-E	1 RP	17.0	23.3	32.9	43.5	60.1	73.7	84.5
LVG 512C-E	1-1/4 RP	28.7	40.7	57.9	76.1	108	131	151
LVG 515C-E	1-1/2 RP	40.2	57.3	80.4	105	149	181	206
LVG 520C-E	2 RP	68.6	94.3	134	176	243	298	340
LVG 525A-E	2-1/2 RP	107	151	214	281	397	486	561
LVG 530A-E	3 RP	140	210	384	368	520	637	735
LVG 540A-E	DN 100	251	355	502	660	934	1,140	1,320

Notes:

1. Capacities based on natural gas @ 0.60 s.g. and 0°C fluid temperature.
2. Pressure drop measured across full open valve.
3. Maximum inlet pressure is 172 kPa.
4. For natural gas leakage rates with fully closed valve, consult Hauck. (See Page 2 For Example)

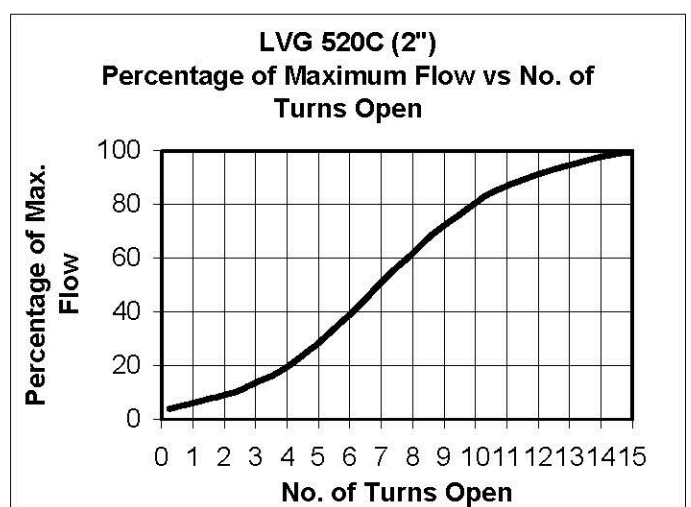
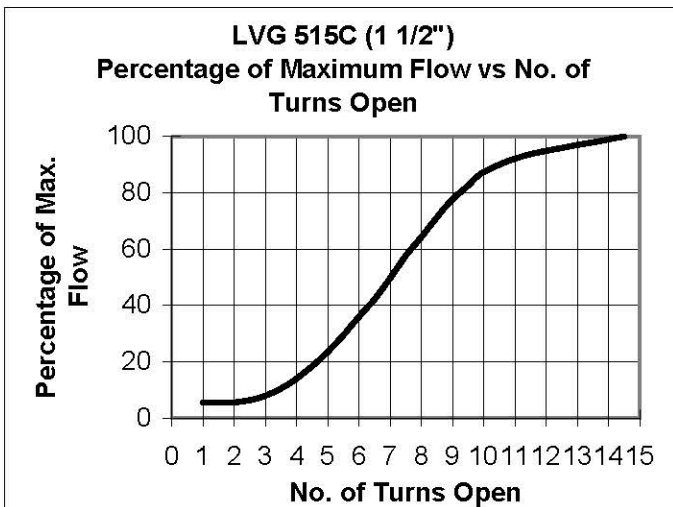
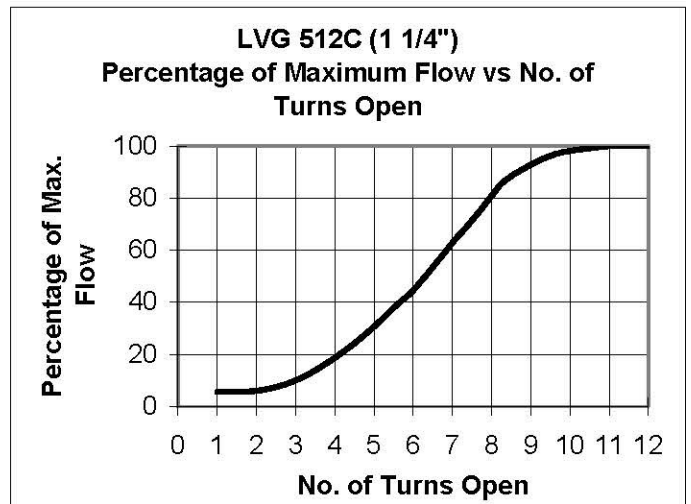
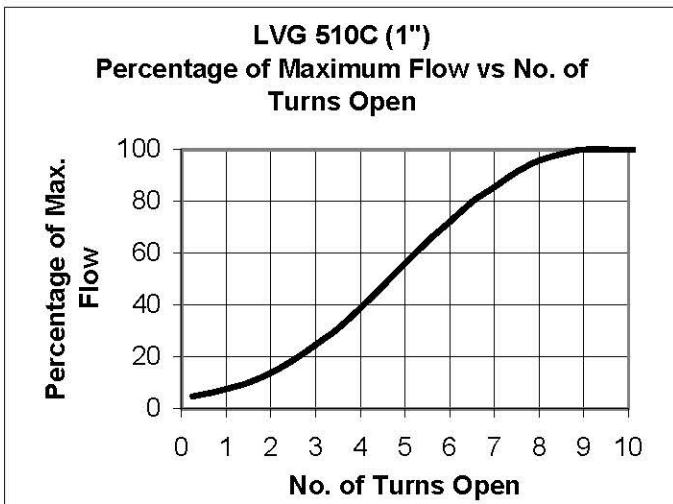
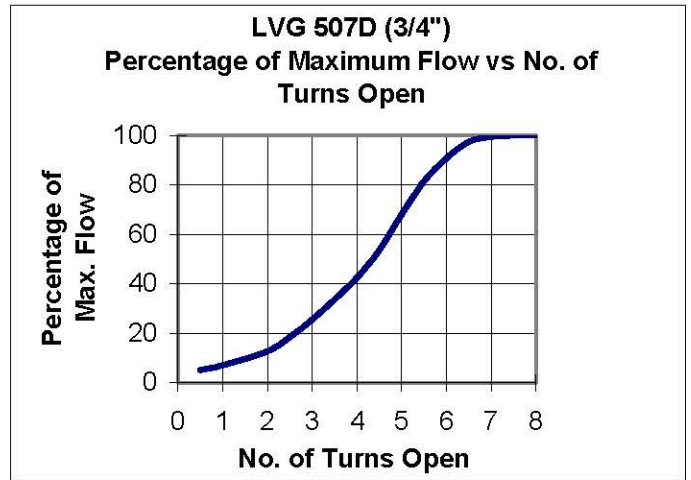
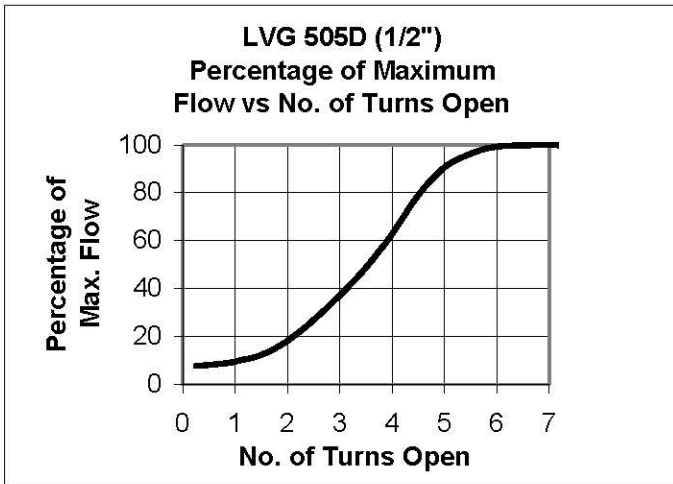

(Graph's for LVG 525 – 540 on Page 4)

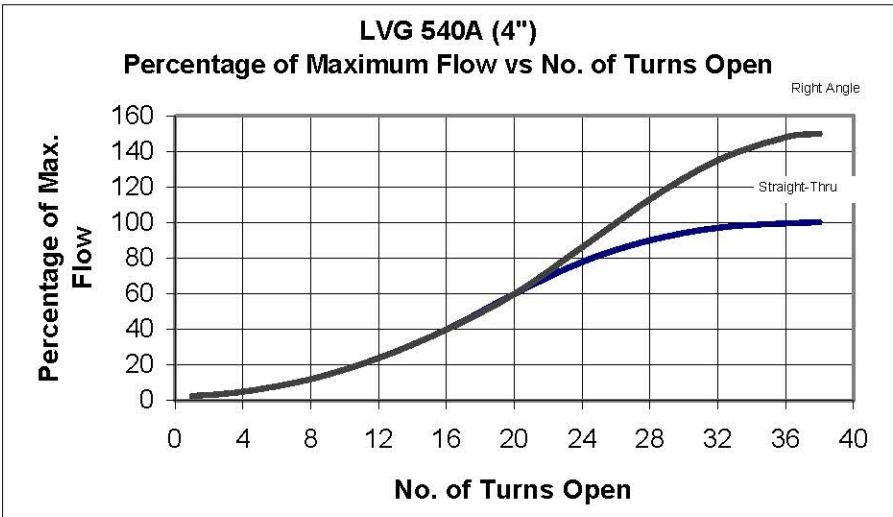
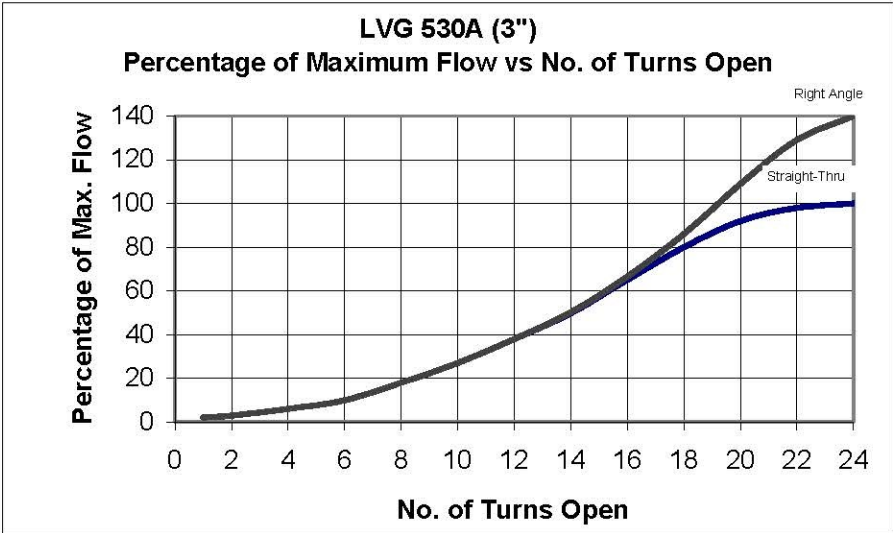
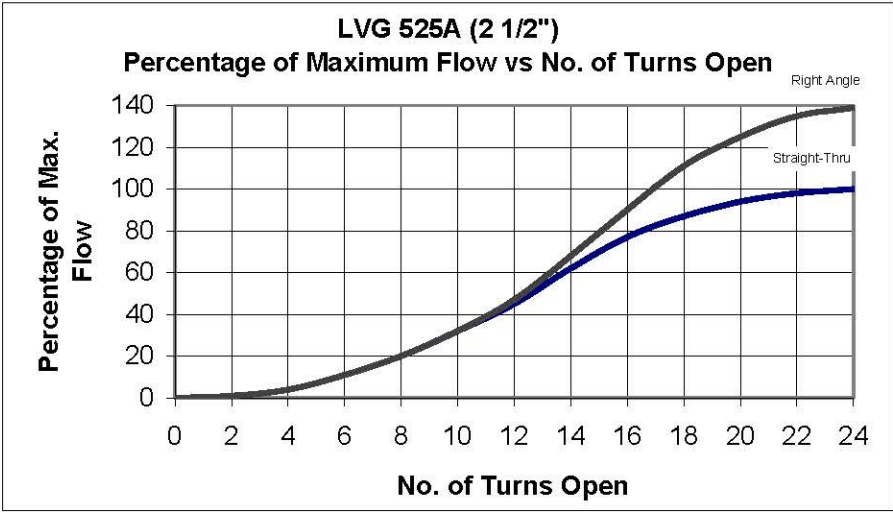



# DIMENSIONS

## GAS LIMITING ORIFICE VALVES LVG SERIES

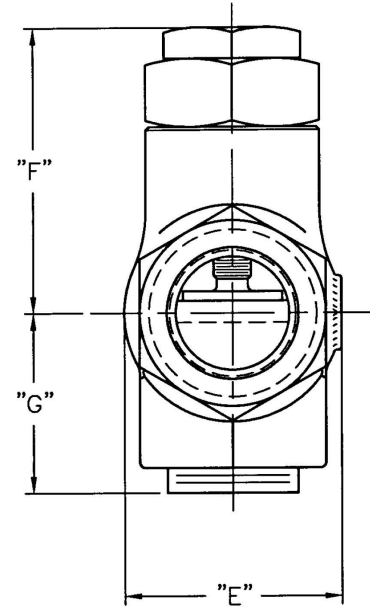
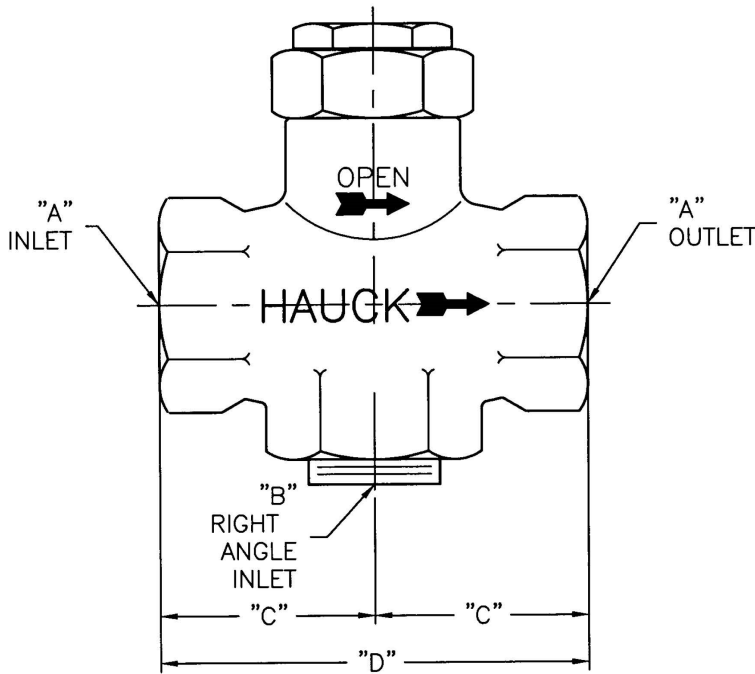

W6715  
(NOT TO SCALE)

MODEL NO.	"A"	"B"	"C"	"D"	"E"	"F"	"G"	APPROX. NET WT.
LVG505D	1/2 NPT	1/2 NPT	2 5/32	4 5/16	2 3/16	2 13/16	1 11/16	3.6 LB
LVG507D	3/4 NPT	3/4 NPT					3.6 LB	
LVG510C	1 NPT	1 NPT					3.6 LB	
LVG512C	1 1/4 NPT	1 1/4 NPT	2 5/8	5 1/4	3 1/4	4	2 3/16	7.3 LB
LVG515C	1 1/2 NPT	1 1/2 NPT					7.3 LB	
LVG520C	2 NPT	2 NPT	2 15/16	5 7/8	3 3/4	4 3/8	2 7/16	12 LB

### METRIC LVG SERIES

MODEL NO.	"A"	"B"	"C"	"D"	"E"	"F"	"G"	APPROX. NET WT.
LVG505D-E	1/2 RP	1/2 RP	55	110	56	71	43	1.6 KG
LVG507D-E	3/4 RP	3/4 RP						1.6 KG
LVG510C-E	1 RP	1 RP					1.6 KG	
LVG512C-E	1 1/4 RP	1 1/4 RP	67	133	83	102	56	3.3 KG
LVG515C-E	1 1/2 RP	1 1/2 RP						3.3 KG
LVG520C-E	2 RP	2 RP	75	149	95	111	62	5.4 KG

(See Reverse Side For LVG525 – LVG540 Dimensions)

(OVER)