

# Vent gas solenoid valve

LGV/5

6.24

**DUNGS**<sup>®</sup>  
Combustion Controls



## Technical description

The DUNGS vent gas solenoid valve LGV/5 is a normally when open, automatic pressure relief as per EN 161 for gas burners and gas appliances.

- Max. operating pressure: 500 mbar (50 kPa)
- Class A, Group 2 as per EN 16304
- **normally open (N.O.)**
- Fast closing
- Fast opening
- DC solenoid, rectifier wiring with radio suppression interference in terminal box
- Mountable closed position signal contact to monitor closed position of valve
- Reliable function, rugged and maintenance-free
- It does not contain any non-ferrous metals, suitable for gases of up to max. 0.1 vol.% H<sub>2</sub>S, dry

## Application

The DUNGS vent gas solenoid valve LGV/5 is suitable for gases of families 1, 2, 3 and other neutral gaseous media.

The vent gas solenoid valve is used for the shut-off and release of upstream gas volumes.

## Approval

EC type testing certificate as per:

- EC-Gas Appliances Regulation
  - EC-Pressure Equipment Directive
- Approvals in other important gas consuming countries.

## Specifications

Nominal diameters	DN 20	
Pipe thread as per ISO 7/1	Rp 3/4	
Flange	Connection flange (PN 16) as per DIN EN 1092-1	
Max. operating pressure	500 mbar (50 kPa)	
Solenoid valve	Valve as per EN 16304	
Closing time	< 1 s	
Opening time	< 1 s	
Materials of gas-conveying parts	Housing:	aluminium, steel, not containing non-ferrous metals
	Seals:	NBR basis
Voltage/frequency	50-60 Hz, 230 V AC (+10% -15%); further voltages on request	
Rating / power consumption	15 VA/0.08 A, at 20°C and 230 VAC	
Switch-on duration	100 %	
Degree of protection	IP 54, IP 65 on request	
Electrical connection	At screw terminals via PG* 11 cable gland (* = heavy-gauge conduit thread) Plug connection as per DIN EN 175301-803, can be retrofitted	
Switching rate	Max. 1000/h	
Measuring/ignition gas connection	G 1/4 ISO 228, on both sides in inlet section	
Ambient temperature	-15°C to +60°C	
Installation position	Solenoid from vertically upright to horizontally lying	
Closed position signal contact	Type K01/1 (DIN-tested), mountable on LGV 5.../5	
Accessories	K01/1 closed position signal contact, see Datasheet 12.01	211 202
	Equipment plug for line socket as per DIN EN 175301-803	215 733

**Dimensions [mm]**  
**LGV 507/5**

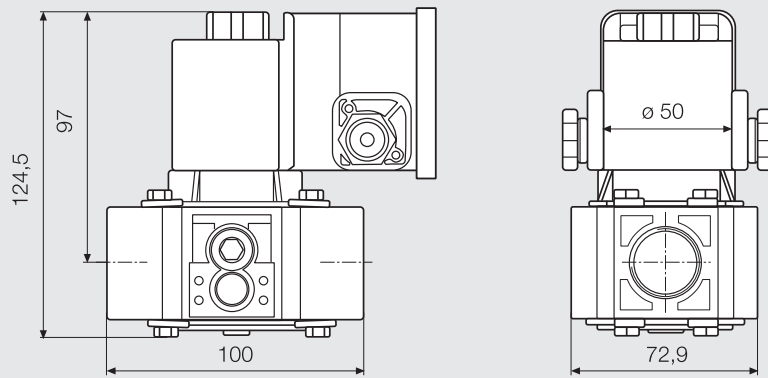

**Dimensions [mm]**  
**LGV 5020/5**

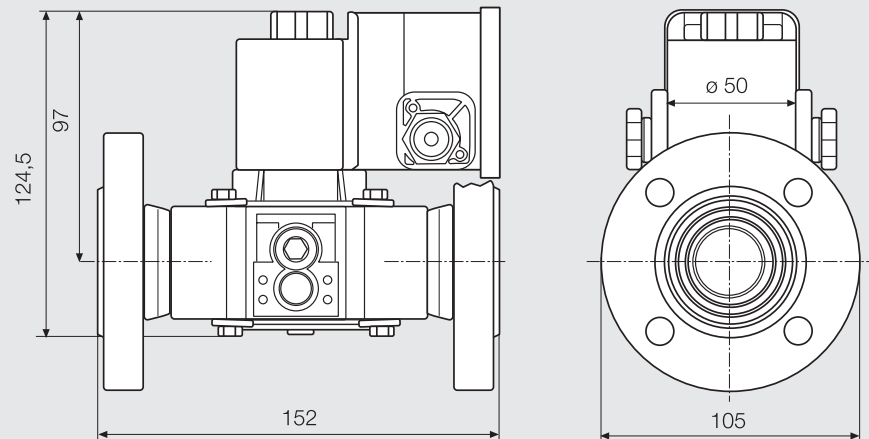

Type	$p_{max.}$ [mbar]	Rp / DN	Order No.	Weight
LGV 507 /5	500	Rp 3/4	119 271	1.3
LGV 5020/5	500	DN 20	119 594	3.2

**Functional description**

The DUNGS vent gas solenoid valve is an automatic shut-off valve operated with auxiliary power. The electromag-

netic drive closes against the force of the pressure spring. If the auxiliary power is interrupted (operating voltage), the pressure spring opens the

valve within 1 second.

The closed position of the valve can be monitored by a mountable closed position signal contact.

Leakage gas  
solenoid valve  
LGV/5

Flow diagram

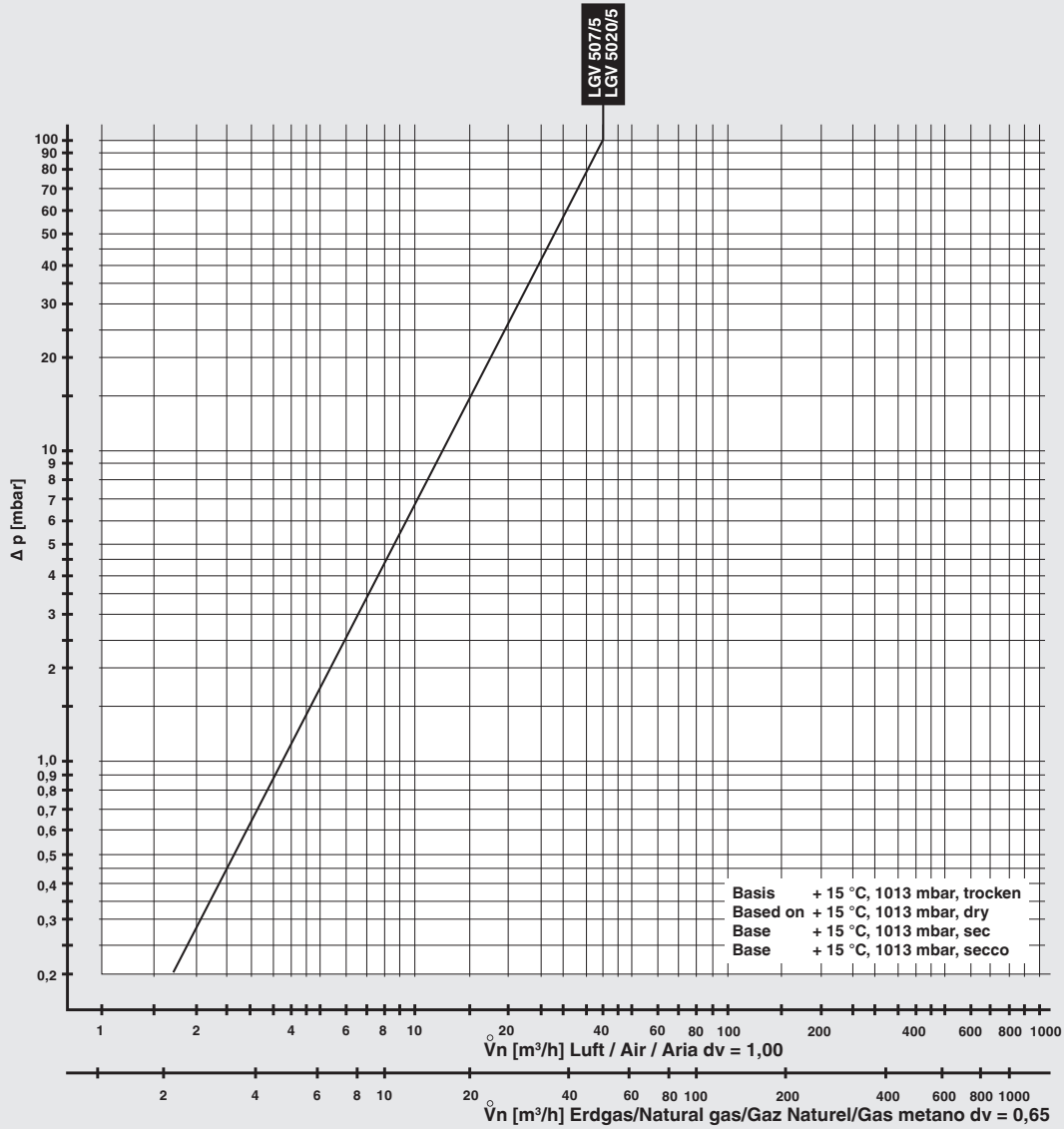

We reserve the right to make any changes in the interest of technical progress.