

# Dimensions & Specifications

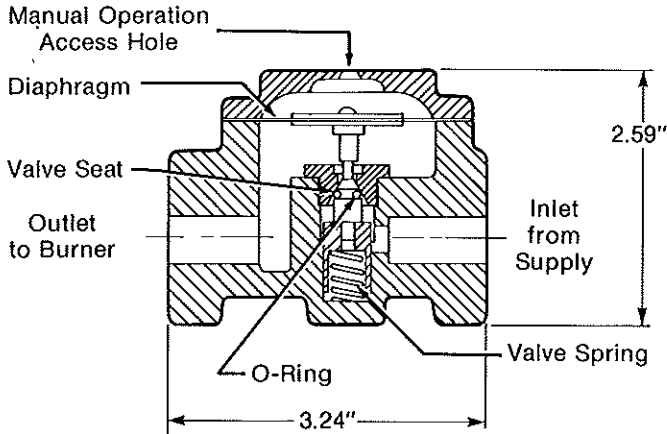
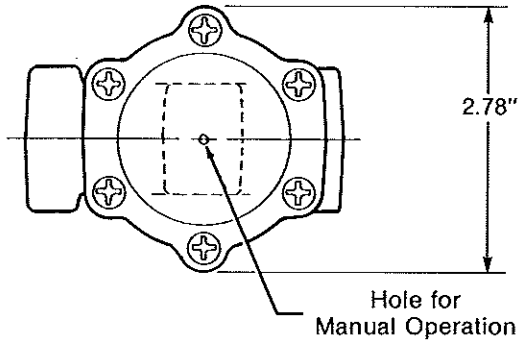

## OSV Series Oil Safety Valves

Two Models Available:

OSVA 38 for 3/8" Pipe; Ports, 3/8 - 18 NPTF  
OSVA 50 for 1/2" Pipe; Ports, 1/2 - 14 NPTF

UL Listed for No. 2 or lighter fuel oil at 60 PSI maximum inlet pressure.

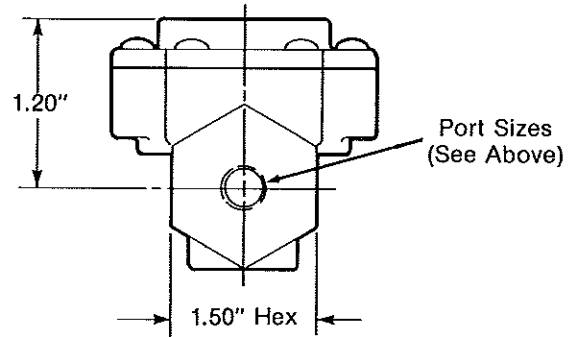

### FEATURES

Webster Oil Safety Valves provide important protection in oil burner supply systems with pressurized supply lines.

By isolating burner fuel pumps from supply line pressure sources (a supply pump or overhead tank, for example), the OSV relieves pressure strain on fuel pump inlets and seals and prevents tank siphoning and spilling caused by accidental line breaks.

The OSV is mounted close to the burner assembly. A sustained vacuum at the outlet side of the OSV, generated by fuel pump operation, causes the valve to open. The OSV operates as a pressure reducer, with supply line pressure on the valve inlet side and fuel pump vacuum on the valve outlet side.

In the event of line breakage between the OSV and the burner pump, loose connection or any other leakage factor large enough to prevent vacuum buildup on operation of the burner pump, the OSV will close or remain closed, preventing oil flow to the burner. Tank siphoning or oil spillage is thus prevented.

Many state and local codes require a device that will automatically shut off the oil supply before it enters a building should the line between the device and the burner be broken. NFPA standards require that the pressure at the burner fuel pumps must not exceed 3 PSI. The Webster OSV satisfies both requirements when properly installed. Check local codes for any special requirements.

### OPERATION

In systems with burners connected for one-pipe operation, GPH flow through the valve is the same as the burner nozzle firing rate. In two-pipe operation, GPH flow through the valve is the same as the fuel pump suction capacity. Refer to fuel pump manufacturer's specifications for inlet suction capacity.

**Operation of OSV valves in parallel or in series is not recommended.**

### Recommended Maximum Flow Rates and Pressure

OSV 38 and OSV 50

Flow thru Valve	Pressure at Valve Inlet, PSI					
	5	15	30	40	50	60
1 GPH	2.5	2.7	3.5	4.5	5.0	5.5
15 GPH	2.7	3.0	4.0	5.0	5.5	6.0
32 GPH	3.7	4.0	4.7	5.2	6.0	7.0
45 GPH	4.0	4.5	5.0	6.0	7.0	
55 GPH	4.5	5.0	5.7	Do not operate in this region		
60 GPH	5.0	5.2	6.0			
70 GPH	5.5	6.0				

Vacuum (inches Hg) to operate valve is shown for various flow and pressure conditions:

Values given are averages of test results and may vary slightly.

# Installation

## Check Local Codes:

Compliance to all applicable codes where installed is the responsibility of the installer. Typical installation diagrams are shown for reference only.

## Mounting:

The OSV can be mounted in any position. Preferred position is with cover down to prevent dirt or moisture accumulation in the diaphragm area through the manual operation access hole.

## Porting Connections:

Connect the supply line to the IN port, and the OUT port to the burner fuel pump. **Do not use teflon tape. Use of teflon tape voids all warranties.**

## Filter:

A reliable in-line filter is recommended between the tank and the OSV to insure maximum seal reliability in the OFF mode.

**CAUTION — Do not mount the OSV more than three feet above the burner fuel pump inlet, or more than three feet above the lowest point in the fuel line connecting the OSV to the burner fuel pump. In-line mounting with the burner fuel pump inlet is recommended.**

Failure to observe the above caution may result in siphoning action in the event of failure of the fuel line between the burner fuel pump and the OSV. See examples in Figures 3 and 4.

## Priming:

For priming purposes the OSV can be manually operated by inserting a stiff wire (paper clip) through the cover hole, and depressing the diaphragm plate. Remove the wire immediately if oil appears at the fuel pump vent, burner fires, or there is any sign of oil at the burner fuel pump.

## Entrapment Caution:

In supply systems having a check valve on the supply pump discharge, an entrapment condition may exist between the supply pump and the OSV. Cold oil in the line in the burner OFF condition expands on heating from room temperature, causing a line pressure rise that may prevent the OSV from operating. The condition may be observed by use of a pressure gauge at the inlet of the OSV, or on the discharge side of the supply pump check valve. Correction requires use of a pressure relief valve as shown in Figure 1, set to insure a maximum 60 PSI at any OSV inlet under all conditions.

## Open Loop System (Figure 2):

To insure a flooded supply line, a standpipe before the junction of the supply line with the return line is required. The standpipe on the supply line must be at least three feet higher than any point in the supply line system before joining the return line. Use of a Webster 48598 vacuum breaker is recommended as shown in Figure 2.

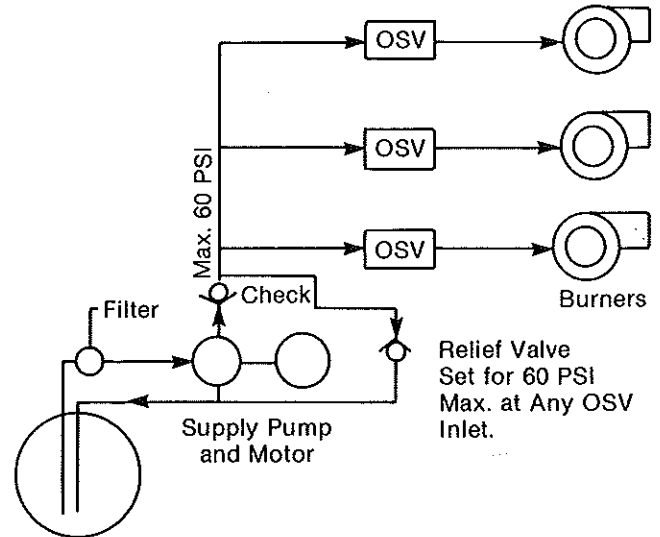

Figure 1 Supply Pump Systems - Multi Level

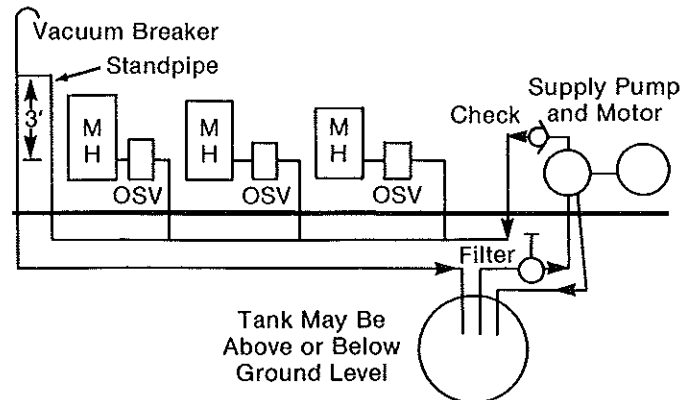

Figure 2 Central Supply System For Mobil Homes

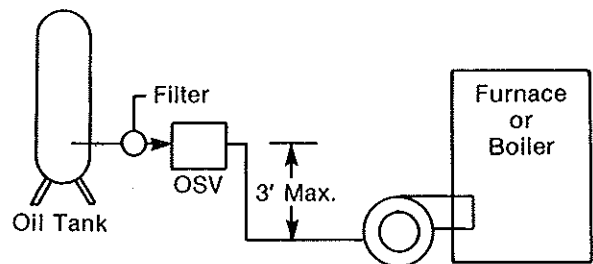

Figure 3 Gravity Feed In Basement

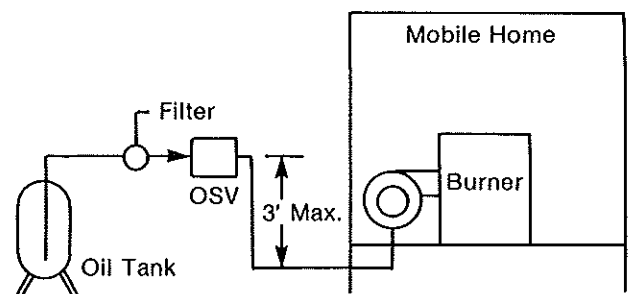

Figure 4 Mobile Home Gravity System

# Webster® Oil Safety Valve (OSV®)

## Technical Installation Bulletin

which is mounted close to the supply tank. Connect both OSV® valves as close to the tee as possible. A line from the output of each OSV® valve would be connected to any additional valves, and then to the burner.

### Gravity-Feed, Single-Pipe, Two-Burner Systems.

Since the OSV® valve is a vacuum activated device, its introduction into a gravity-feed system changes the pressure characteristics to the input of the pump from a normal positive pressure to a vacuum. Pumps employed on single-pipe systems are single-stage pumps, and are very sensitive to the presence of air or gasses. Dissolved gasses and air are removed from some fuel oils at vacuums just above 6 inches of mercury. For reliable operation it is recommended that single-pipe systems not be operated above 6 inches of mercury vacuum at the pump input, even though the pump is capable of producing 10 inches of mercury vacuum. It is important to consider the frictional losses in vacuum from each component in the system, such as piping, fittings, valves and filters. The amount of vacuum required should be known at the maximum firing rate of the burners at the coldest temperatures the oil will be subjected to during the heating season. Table 2 gives frictional loss in a horizontal run of copper tubing equivalent to a vacuum of 1 inch of mercury, at various flow rates and oil temperatures.

Figure 2 depicts a typical single-pipe, gravity-feed system without an OSV® valve and two burners. Because of the limited vacuum capability of a single-pipe system, and the requirement for oil spill protection, it is recommended that 2 OSV® valves be used, one for each burner, as shown in Figure 3. Do not use a single OSV® valve for both burners. A possible installation would be to introduce a tee immediately following the filter,

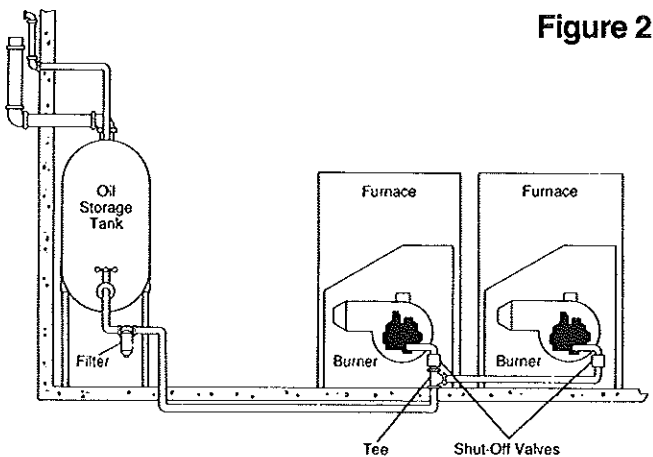

Figure 2

Figure 2 Gravity-Feed, Single- Pipe, Two Burners Without OSV Valves

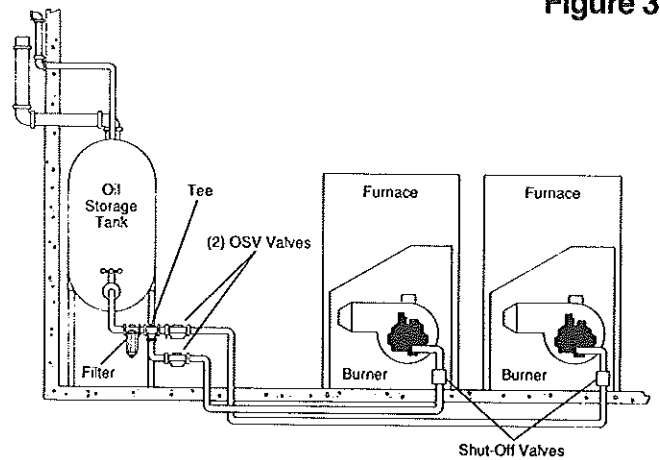

Figure 3

Figure 3 Gravity-Feed, Single- Pipe, With OSV Valves

Flow Rate (GPH)	Temperature Degrees F		
	0	40	70
	Tube Length (Feet)	Tube Length (Feet)	Tube Length (Feet)
½ inch copper tubing			
1	27.0	84	152
2	13.6	42	75
3	9.1	28	50
4	6.8	21	38
5	5.0	16	30
6	4.5	14	25
¾ inch copper tubing			
1	82.0	253	458
2	40.0	126	229
3	27.0	84	153
4	20.0	63	144
5	16.0	50	91
6	13.6	42	76
1 inch copper tubing			
1	243	749	354
2	121	374	677
3	80	249	451
4	60	187	338
5	48	149	270
6	40	124	225

Table 2

Maximum horizontal run for copper tubing that will result in 1 inch of vacuum loss due to friction. Values are given for indicated flow rates and temperatures. Use for one or two burners operating on single-pipe systems.