Regulating Valves for Oil Heating Systems



Webster RV Series valves are designed to provide fuel oil pressure regulation in oil heating applications such as transfer or supply pump systems or high firing capacity burners. RV valves will handle #1 thru #6 grade fuel oil in rated pressures ranging from 0 to 500 psi (0 to 34.5 bar).

RV-2100 series models regulate pressure for capacities to 150 gph (568 l/hr.) and RV-3000 series valves regulate pressure to 600 gph (2270 l/hr.). RV-2000 models regulate pressure and also provide delivery cut-off for capacities to 100 gph (378 l/hr.)

Webster® Fuel Pumps & Valves

219 Hahn Road, Frankfort, Kentucky 40601
(502) 223-0025 • (800) 766-1233 • Fax: (502) 223-4629

specifications

RV-2000

For all fuel oils, No. 1 through No. 6. Combines pressure regulation and cut-off. Chrome plated piston valve and improved composition sealing disc resist corrosion; gives positive seal and sharp, clean cut-off Capacities to 100 GPH.

RV-2100

Same as RV-2000 except does not have delivery cut-off. Pressure regulating only. Capacities to 150 GPH.

RV-3000

Same as RV-2100 except capacities to 600 GPH.

SELECTION TABLE					
Model			Adjustment	Capacity	Factory
Number	Porting	Description	Range	GPH	Set PSI
RV2001	3/8	Regulating with Cut-Off	100-165	100	100†
RV2002	3/8	Regulating with Cut-Off	100-330	100	100†
RV2003	3/8	Regulating with Cut-Off	10-25	100	10†
RV2004	3/8	Regulating with Cut-Off	40-110	100	100†
RV2101	3/8	Regulating	100-165	150	100†
RV2102	3/8	Regulating	100-330	150	100†
RV2102E	3/8	Regulating	100-330	150	250†
RV2103	3/8	Regulating	10-25	150	10†
RV2104	3/8	Regulating	40-140	150	100†
RV2101-1	1/4	Special	100-165	150	100†
RV2101-4	1/4	Regulating	100-165	150	150*
RV2102-4	1/4	Valves	100-330	150	150†
RV2102-4A	1/4	(See Note 1)	100-330	150	100*
RV2102-4B	1/4	"	100-330	150	125*
RV2102-4C	1/4	"	100-330	150	150*
RV2102-4D	1/4	"	100-330	150	200*
RV2102-4E	1/4	"	100-330	150	250*
RV2102-4J	1/4	"	100-330	150	300*
RV2104-2	1/4	"	80-140	150	100*
RV2104-3	3/8	"	80-140	150	100*
RV2104-4	1/4	"	80-40	150	100*
RV3000	3/4	Regulating	250-550	600	250†
RV3001	3/4	Regulating	50-330	600	100†
RV3001DAR	3/4	Special Regulating	50-330	600	100†
RV3002	3/4	Regulating	50-220	600	100†
RV3003	3/4	Regulating	10-55	600	10†

(PSI Range and setting based on 50 GPH flow, #2 Fuel Oil, except RV3000 series is based on 150 GPH flow)

Valve may be reset at installation to meet system requirement.

*Valve stamped at factory with present pressure.

†Valve not stamped with factory present pressure.

NOTE 1: These special valves meet the requirements of the New York City's Board of Air Resources. The valve body dimensions are the same as those shown at the right for the RV2000 and RV2100 series valves. Differences are: 1. The top and bottom valve and caps are taper pinned to the body to prevent removal. 2. The pressure adjustment seal screw and washer once installed by the customer, cannot be removed to prevent tampering with the set pressure. 3. All inlets and outlets are tapped for 1/4-18 NPTF fittings except the RV2104-3 which is 3/8-18 NPTF.

dimensions

RV-3000

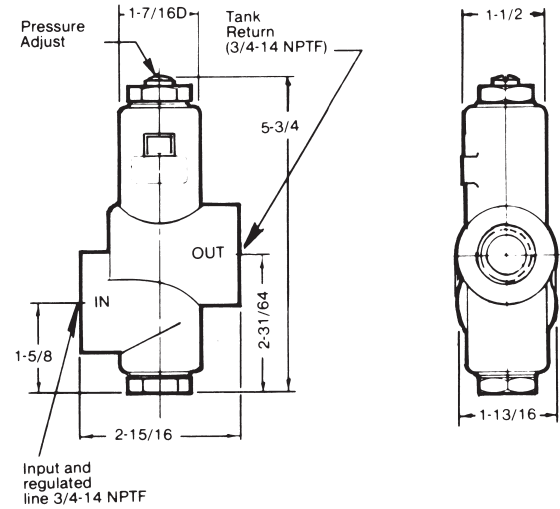

RV-2000 RV-2100

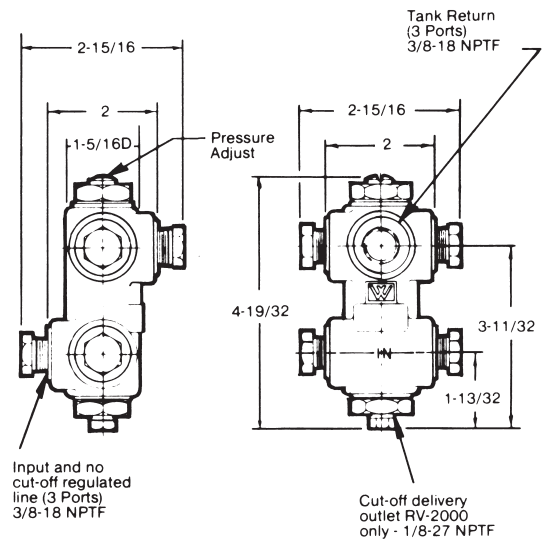

Installation

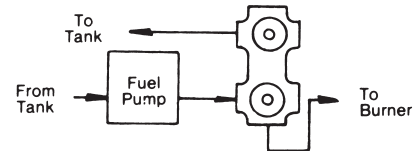

RV-2000

Valve Regulation with Cutoff

RV-3000

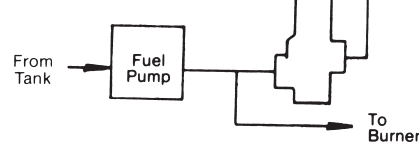

Valve Regulation without Cutoff

RV-2100

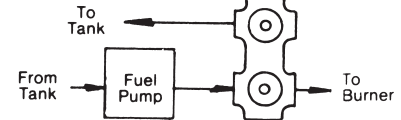

Valve Regulation without Cutoff